



Topic  
Science

Subtopic  
Physics & Chemistry

# Nuclear Physics Explained

Course Guidebook

Professor Lawrence Weinstein  
Old Dominion University

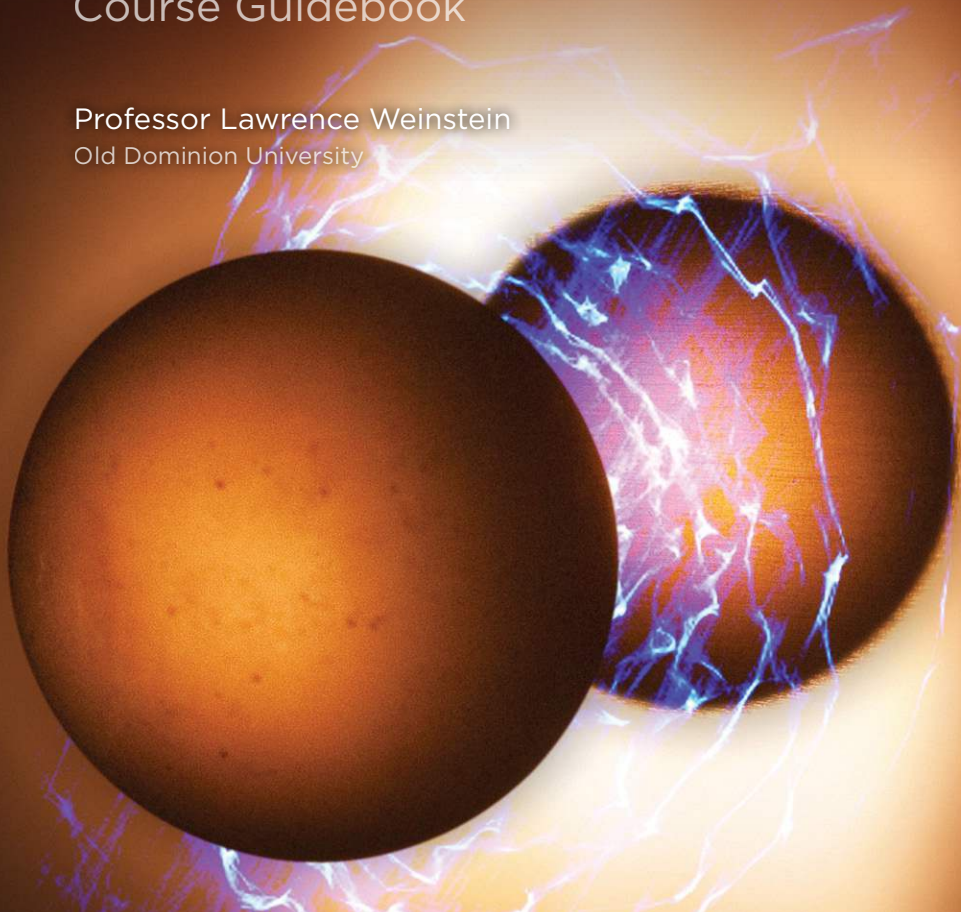

Published by

# THE GREAT COURSES

## Corporate Headquarters

4840 Westfields Boulevard | Suite 500 | Chantilly, Virginia | 20151-2299

[PHONE] 1.800.832.2412 | [FAX] 703.378.3819 | [WEB] [www.thegreatcourses.com](http://www.thegreatcourses.com)

Copyright © The Teaching Company, 2018

Printed in the United States of America

This book is in copyright. All rights reserved. Without limiting the rights under copyright reserved above, no part of this publication may be reproduced, stored in or introduced into a retrieval system, or transmitted, in any form, or by any means (electronic, mechanical, photocopying, recording, or otherwise), without the prior written permission of The Teaching Company.



## Lawrence Weinstein, PhD

*Professor of Physics  
Old Dominion University*

Lawrence Weinstein is a Professor of Physics at Old Dominion University (ODU) and a researcher at the Thomas Jefferson National Accelerator Facility (Jefferson Lab). He received his bachelor of science degree in Physics from Yale University and his doctorate in Physics from the Massachusetts Institute of Technology. Professor Weinstein's research involves experimental nuclear physics, using electron scattering to study the structure of the nucleus and the structure of the proton, both inside and outside the nucleus.

Prior to arriving at ODU, Professor Weinstein conducted research at MIT, performing experiments at the Bates Linear Accelerator Center. His significant contributions include building major pieces of equipment for Jefferson Lab, measuring how nucleons behave singly and in pairs in nuclei, using an antimatter beam to measure the structure of the proton, and discovering the correlation between nucleon pairing and bound nucleon structure modification. Professor Weinstein's current research focuses on short-range correlations in nuclei and on the quark structure of bound nucleons.

Professor Weinstein has won a plethora of teaching and research awards. In addition to several awards from the ODU College of Sciences, he received the ODU Teaching with Technology Award, was named University Professor for his outstanding teaching, and received the A. Rufus Tonelson Faculty Award from ODU, the George B. Pegram Award for Excellence in Physics Education in the Southeast from the American Physical Society, and the Virginia Outstanding Faculty Award. In recognition of his research, Professor Weinstein was named an Eminent Scholar, a distinction reserved for only 4% of the ODU faculty, and was named a fellow of the American Physical Society. In addition, he was elected chair of the 1600-member Jefferson Lab Users Group to represent all the scientists performing research at Jefferson Lab.

Professor Weinstein is the author of 2 popular books—*Guesstimation: Solving the World's Problems on the Back of a Cocktail Napkin* (with John Adam) and *Guesstimation 2.0: Solving Today's Problems on the Back of a Napkin*—about techniques for approximate solutions to any problem. He and *Guesstimation* were featured in *The New York Times* and *National Geographic* magazine. Professor Weinstein has coauthored more than 200 publications in professional journals, with more than 10,000 citations. He has given more than 110 professional presentations, in addition to more than 75 talks and physics demonstration shows for community groups, high schools, and middle schools. ◆

# TABLE OF CONTENTS

## Introduction

Professor Biography . . . . .	i
Disclaimer . . . . .	v
Course Scope . . . . .	1

## Guides

1 A Tour of the Nucleus and Nuclear Forces . . . . .	4
2 Curve of Binding Energy: Fission and Fusion . . . . .	14
3 Alpha, Beta, and Gamma Decay . . . . .	24
4 Radiation Sources, Natural and Unnatural . . . . .	35
5 How Dangerous Is Radiation? . . . . .	44
6 The Liquid-Drop Model of the Nucleus . . . . .	55
7 The Quantum Nucleus and Magic Numbers . . . . .	66
8 Particle Accelerators: Schools of Scattering . . . . .	77
9 Detecting Subatomic Particles . . . . .	88
10 How to Experiment with Nuclear Collisions . . . . .	98
11 Scattering Nucleons in Singles or in Pairs . . . . .	107
12 Sea Quarks, Gluons, and the Origin of Mass . . . . .	120

13	Nuclear Fusion in Our Sun . . . . .	131
14	Making Elements: Big Bang to Neutron Stars . . . . .	141
15	Splitting the Nucleus. . . . .	154
16	Nuclear Weapons Were Never “Atomic” Bombs. . . . .	164
17	Harnessing Nuclear Chain Reactions. . . . .	175
18	Nuclear Accidents and Lessons Learned . . . . .	184
19	The Nuclear Fuel Cycle and Advanced Reactors. . . . .	198
20	Nuclear Fusion: Obstacles and Achievements . . . . .	210
21	Killing Cancer with Isotopes, X-Rays, Protons . . . . .	224
22	Medical Imaging: CT, PET, SPECT, and MRI . . . . .	235
23	Isotopes as Clocks and Fingerprints . . . . .	246
24	Viewing the World with Radiation . . . . .	258

## Supplementary Material

	The Periodic Table of the Elements . . . . .	270
	The Chart of Nuclides . . . . .	274
	Glossary . . . . .	276
	Select Nuclear Physics Research Facilities . . . . .	303
	Timeline . . . . .	305
	Nobel Laureates . . . . .	317
	Bibliography . . . . .	321
	Image Credits . . . . .	335

# DISCLAIMER

This series of lectures is intended to increase your understanding of the principles of nuclear physics. These lectures include demonstrations in the field of nuclear physics, performed by an experienced professional. These experiments may include dangerous materials and are conducted for informational purposes only, to enhance understanding of the material.

**WARNING: THE DEMONSTRATIONS PERFORMED IN THESE LECTURES CAN BE DANGEROUS. ANY ATTEMPT TO PERFORM THESE DEMONSTRATIONS ON YOUR OWN IS UNDERTAKEN AT YOUR OWN RISK.**

The Teaching Company expressly **DISCLAIMS LIABILITY** for any **DIRECT, INDIRECT, INCIDENTAL, SPECIAL, OR CONSEQUENTIAL DAMAGES OR LOST PROFITS** that result directly or indirectly from the use of these lectures. In states that do not allow some or all of the above limitations of liability, liability shall be limited to the greatest extent allowed by law.



# NUCLEAR PHYSICS EXPLAINED

Nuclear physics is all about the nucleus—which is only 0.0001 the size of the atom but contains 99.9% of the atom’s mass—including the forces that hold nuclei together or allow them to decay; the chart of nuclides, which shows the myriad of stable and unstable nuclei; nuclear decay and transmutation; energy release through fusion or fission; nuclear medicine; and many other applications.

The curve of binding energy [[LECTURE 2](#)] shows the pattern by which some elements can undergo fission to produce energy, while others undergo fusion. Nuclei that are too heavy, or have too many protons or neutrons, are unstable and emit radiation [[LECTURE 3](#)]. These radioactive nuclei occur naturally all around us [[LECTURE 4](#)], but too much radiation can cause sickness, cancer, or even death [[LECTURE 5](#)].

You will learn about nuclei by exploring models that predict their features, starting with the simplest model, the liquid-drop model, and adding quantum mechanics slowly, first with the Fermi gas model (which also describes the largest nuclei of all, neutron stars) [[LECTURE 6](#)] and then with the shell model (where protons and neutrons occupy shell-model orbitals in the nucleus just like electrons in the atom) [[LECTURE 7](#)] to describe nuclei more and more precisely.

You will then get a detailed inside look at the experimental techniques used to study the nucleus by visiting a detector lab [LECTURE 9] and the Thomas Jefferson National Accelerator Facility (Jefferson Lab) to tour the mile-long accelerator and several of its massive experimental halls [LECTURES 8 AND 10-12].

You will discover how accelerators smash high-energy particles into nuclei [LECTURE 8] to study nuclear structure, to make new ultraheavy nuclei, or to recreate the conditions of the early universe by making a quark-gluon plasma. You will learn how scientists use particle detectors to detect the high-energy particles from these subatomic collisions [LECTURE 9] and perform nuclear physics experiments with spectrometers (combinations of magnets and particle detectors) that can measure these particles [LECTURE 10]. You will explore a series of experiments that show how protons and neutrons behave in the nucleus [LECTURE 11] and how the protons and neutrons are each made of the 3 standard quarks plus the host of virtual quark-antiquark pairs (known as sea quarks) and gluons that account for about 98% of all ordinary mass [LECTURE 12].

Nuclear fusion powers the universe. Our Sun gets its energy by fusing hydrogen into helium [LECTURE 13]. Heavier stars can get energy by fusing lighter elements into heavier ones, culminating in iron. Even heavier nuclei are made in stars, in supernovas, and even in neutron-star collisions [LECTURE 14]. Scientists have used the elusive neutrino to look deep into our Sun and into supernovas to show that supernovas emit an astounding 99% of their energy in the form of neutrinos.

The process of nuclear fission is used to release energy. You will discover why certain isotopes fission [LECTURE 15], how nuclear weapons work and how to produce or concentrate those fissile isotopes [LECTURE 16], how to generate electricity from nuclear fission [LECTURE 17], and the causes and consequences of nuclear accidents [LECTURE 18]. Better ways to produce nuclear energy can improve safety and reduce nuclear waste with possible advanced nuclear power plants, including pebble-bed and liquid

fluoride-thorium reactors [LECTURE 19]. The ideal power supply of the future could be controlled nuclear fusion [LECTURE 20], converting heavy hydrogen to helium at extremely high temperatures and pressures.

But nuclear physics is not just about fission and fusion. Radioactive sources and particle beams are used to fight cancer with radiation, such as at the Hampton University Proton Therapy Institute, where scientists attack tumors with proton beams [LECTURE 21]. Nuclear techniques are also used in medical imaging, including x-rays and CT scans, PET and SPECT scans, and MRIs [LECTURE 22].

The many different isotopes of each element, both stable and unstable, can be used to date or identify objects. You will learn how radioactive isotopes such as carbon-14 are used to date archaeological finds and how stable isotopes are used to study Paleolithic diets [LECTURE 23]. Scientists also use radiation to view the world around us, from placing nuclear physics experiments down oil wells to guide drilling, to scanning cargo containers for suspicious materials [LECTURE 24].

By the time you complete this course, you will appreciate the glorious complexity of the atomic nucleus and its remarkable range of applications, from powering the universe and creating the elements to identifying fake vanilla, detecting art forgeries, and curing cancer. ♦

# 01

## A TOUR OF THE NUCLEUS AND NUCLEAR FORCES

The **nucleus** of an atom consists of **protons** and **neutrons**, which are held together by the **strong nuclear force**. That force is 100 times stronger than the electric force, which holds a positive nucleus and the negative **electrons** together in the atom. **Nuclear physics** studies how the energy changes when nuclei are combined and when they are taken apart. This lecture will offer a whirlwind tour of nuclear physics; these topics will be explored again, step by step, later in the course. ◆

## The Chart of Nuclides

- ◆ The periodic table [PAGE 270] is great for organizing atoms. Simply count the number of protons, and there will be the same number of electrons if it's a neutral atom. Each **element** corresponds to a specific number of protons.
- ◆ But each element has more than one possible nucleus. These **isotopes**, what physicists call **nuclides**, have a different number of neutrons. For example, carbon has 6 protons. Carbon-12, with 6 protons and 6 neutrons, is the most common isotope. It's the most stable one. Carbon-14 still has 6 protons, but with 8 neutrons, it is famously unstable. But carbon has isotopes ranging from carbon-8, with only 2 neutrons, to carbon-23, with 17 neutrons.
- ◆ Chemists are justly proud of the periodic table, with more than 100 elements. But nuclear physicists are even more proud of another table, organizing more than 3000 isotopes into the **chart of nuclides** [PAGE 274]. It shows all of the known nuclei, and more are added all the time. The number of protons is on the  $y$ -axis, while the number of neutrons is on the  $x$ -axis, and the nuclei appear in a band that runs from the bottom-left of the graph to the top-right.

---

Visit <https://www.nndc.bnl.gov/chart/> to see a comprehensive and interactive chart of nuclides.

---

- ◆ About 250 isotopes are so stable that they never change on their own. They inhabit the **valley of stability**, and 80 of the familiar elements have at least 1 member—1 stable isotope.

- ◆ In addition to the stable nuclides, another 80 or more nuclides found on Earth decay naturally, some very slowly. From 1901, Ernest Rutherford and Frederick Soddy began to notice parts of what we now call the thorium decay chain. They found that thorium, element 90, spontaneously decays into radium, element 88. Then, radium spontaneously decays to radon, which is element 86, with 86 protons. And this process continues.

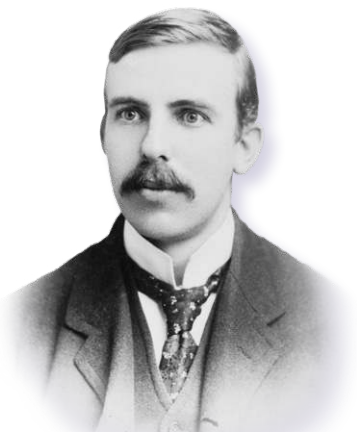

---

**ERNEST RUTHERFORD**

1871–1937

- ◆ Rutherford had already named the 3 types of decay **radiation**, even before there was any evidence that elements were being transmuted. So, he called this **alpha decay**, in which a nucleus gives up 2 protons and 2 neutrons. In **beta decay**, a nucleus emits an electron and 1 of the neutrons that emits that electron turns into a proton. In gamma decay, the nucleus emits a high-energy **photon**, which is a high-energy particle of light.
- ◆ The geology of our planet depends on this spontaneous transmutation of elements. Very slow decays of uranium, thorium, and even an isotope of potassium provide the heat that keeps the Earth's core molten so that the Earth remains geologically active and the continents keep drifting. This happens because these isotopes have very long half-lives, comparable to the age of the Earth. Other isotopes decay much more quickly.

Frederick Soddy coined the word “isotope,” and H. G. Wells dedicated his story about “atomic bombs” to him.

- ♦ Isotopes used in nuclear medicine diagnosis have half-lives that range from a few minutes to several days. After 1 **half-life**, half of the original isotope has transmuted into a different isotope. After 10 half-lives, 99.9% of the original isotope has transmuted into a different isotope. This was originally quite shocking. Atoms had been thought the permanent, fundamental building blocks of the universe.
- ♦ When Marie Curie introduced the notion of **radioactivity**, she was describing properties of a new element that she had discovered: thorium. But she also showed that atoms can decay and therefore are not the fundamental unit of matter.
- ♦ The 20<sup>th</sup> century was the first century of nuclear physics, beginning with Wilhelm Conrad Röntgen's discovery of **x-rays** in 1899 and Rutherford's discovery of the nucleus in 1911. Since then, dozens of nuclear physics Nobel Prizes have been awarded in both physics and chemistry (**PAGE 317**). Nuclear physics developed only recently because the nucleus is so much smaller: The nucleus is 10,000 times smaller than the atom.
- ♦ Individual neutrons and protons, called **nucleons**, are even smaller than the nucleus. They are about  $10^{-15}$  meters, which is 1 femtometer, called 1 fermi, in honor of nuclear physicist Enrico Fermi. **Quarks** and **gluons** are at least 1000 times smaller than that.



---

**MARIE CURIE**  
1867–1934

- ◆ Nuclei are small, but they contain 99.9% of the atom's mass. They are made of protons and neutrons, and the number of protons determines a chemical element. Chemists generally don't care about the number of neutrons.

Chemists average the total number of protons plus neutrons into something

called the atomic weight. Protons provide the electric field that keeps the electrons in orbit, but the electric field pushes protons apart. What holds the nucleus together?

If the nucleus is the size of a tennis ball, then the outermost electrons orbit 5 football fields away.

- ◆ At small scales, we encounter the strong nuclear force. This affects both protons and neutrons equally, and we need both protons and neutrons to make the nucleus stable. The strong nuclear force is holding it together while the repulsive electric force is trying to push it apart, and the nuclei that result come from the interplay between these 2 forces.

Both nuclear physics and particle physics are subatomic, and both use accelerators. But while particle physics (also called high-energy physics) studies the particles themselves, nuclear physics studies how the particles combine—how protons and neutrons combine to form the nucleus and how quarks and gluons combine to form the protons and neutrons.

- ◆ This interplay changes as nuclei get larger. Lighter nuclei have about equal numbers of protons and neutrons, but the heavier nuclei have up to 1.6 times more neutrons to make up for the electrical repulsion of all those protons.
- ◆ If we leave the valley of stability, there are 2 possibilities. There may be too many protons, resulting in too much positive charge, so the nucleus needs to get rid of protons. It does this

by beta-plus ( $\beta^+$ ) decay, in which the proton decays to a neutron, plus a beta-plus particle—which is a positively charged electron called a **positron**, which is the antiparticle of the electron—and a **neutrino**. Alternatively, a proton can combine with an electron to become a neutron plus a neutrino.

- ◆ The other possibility is there may be too many neutrons, which means there are not enough protons, so the nucleus needs to get more protons. It does this by beta-minus ( $\beta^-$ ) decay, in which the neutron decays to a proton, plus an electron, plus an antineutrino.
- ◆ Nuclear waste is basically a problem of excess neutrons in the **fission** products compared with the same number of neutrons in the original uranium or plutonium. As the fission products decay, they change neutrons to protons and move up and to the left on the chart of nuclides toward the valley of stability.

## Studying Nuclei

- ◆ Nuclear physics studies where nuclei come from. The nuclei from hydrogen to helium were made in the **big bang**. The nuclei from helium to iron are made in stars, and heavier elements from iron all the way up were made in **supernovas** and neutron-star collisions.
- ◆ There are 3000 nuclides on the chart of nuclides but only a few hundred that we've detected on the Earth. The other 90% of the known nuclides have already vanished from Earth because they decayed away. Their half-lives were too short, and we only know about them because we've been able to create them in a laboratory. Nuclides no longer found on Earth may turn out to have been very important to our very existence.

- ◆ We study nuclei the same way a 5-year-old studies an alarm clock: We hit it hard and see what comes out. To hit it hard, we need a very small—subatomic—hammer. And we use a variety of large **accelerators** to accelerate different types of hammers, such as electrons, protons, and other nuclei. Then, we use large particle **detectors** to measure the individual subatomic particles that emerge from these collisions.
- ◆ We reconstruct the subatomic collisions using energy and momentum conservation, just as we reconstruct car crashes to find out who was at fault. The difference is collisions between cars damage the cars, sometimes severely, while subatomic collisions can make new nuclides. We can knock nucleons out of a target to make smaller nuclei, or we can combine 2 nuclei to make larger ones.
- ◆ We study nuclei because we want to learn how the world works. Understanding nuclear physics leads to using external beams (of x-rays or protons) or internal radioactive isotopes for medical imaging, medical treatment (such as killing cancers), and even industrial, archaeological, and art analysis.
- ◆ Atoms are made of electrons orbiting the nucleus. Nuclei are made of nucleons—neutrons and protons—orbiting each other. Nucleons, like electrons, obey a fundamental rule: 2 identical particles cannot occupy the same state at the same time. This is called the **Pauli exclusion principle**. Because of this principle, electrons occupy orbitals, such as *s*-shell and *p*-shell orbitals, in atoms. Protons and neutrons occupy similar *s*-shells and *p*-shells in nuclei, just in a different order.
- ◆ Just like atoms, nuclei can be in **excited states** and then deexcite by emitting a photon, visible light for an atom, or a gamma ray for a nucleus.

The average American pays \$2 per year for basic nuclear physics research for a combination of basic knowledge and useful applications.

## The Fundamental Forces of Nature

- ◆ Nuclear physics makes use of all 4 of the fundamental forces of nature: gravity, electricity and magnetism, the **weak nuclear force**, and the strong nuclear force.

- 1 It may be surprising that gravity is important for nuclei. It's the most important force at large scales, but on small scales, it's the weakest force. It's  $10^{-20}$  times as strong as the electromagnetic force. Gravity affects things with mass. It's crucial for **neutron stars**, which are the biggest nuclei there are. They have about 10% protons and 90% neutrons. Their mass is 1 to 2 times the mass of our Sun, but the radius is only about 10 kilometers, or 6 miles.
- 2 Electricity and magnetism cause the protons in the nucleus to repel each other and attract the electrons to the nucleus to form atoms. The electromagnetic force extends over the entire nucleus and is responsible for gamma radiation.
- 3 The weak nuclear force affects all things. You might think that this is a misnomer, because the weak nuclear force is stronger than gravity at very short ranges, but it is called the weak nuclear force not in distinction to gravity, but in distinction to the strong nuclear force. The weak nuclear force is carried by massive particles called the W and Z bosons, which each have 100 times the mass of a proton. But because they're so massive, the weak force has the smallest range of all the forces:  $\frac{1}{500}$  the radius of a proton. The weak force does not help hold the nucleus together; instead, it can change protons into neutrons, or vice versa, through beta decay if the nucleus is on the slopes of the valley of stability.
- 4 The strong nuclear force is the most important of the forces for this course. At a fundamental level, the strong force holds quarks together into protons and neutrons. This same strong force also "leaks out" of the protons and neutrons to hold the entire nucleus together. Quarks

have colors—red, green, and blue—instead of charges; therefore, this force is called quantum chromodynamics. It is carried by particles called gluons and is very strong. The neutrons and protons are made of 3 quarks each (mostly). The full quark structure of the nucleon is very complicated: There are 3 quarks, but there are also quark-antiquark pairs. The strong force is about a million times stronger than the weak force.

- ♦ Atoms change in 3 fundamental ways: alpha decay, when the strong force can't hold the nucleus together; beta decay, which converts protons to neutrons, or vice versa, via the weak force; and gamma decay, which is a release of excess electromagnetic energy.

## Supplements

### READINGS

Lilley, *Nuclear Physics*, chap. 1.

Mackintosh, *Nucleus*.

National Research Council, *Nuclear Physics*, Overview, p. 9–30.

Wilczek, “The Origin of Mass.”

### QUESTIONS

- 1 How would the Earth be different if the half-lives of the longest-lived radioactive uranium, thorium, and potassium isotopes were only 100 million years, rather than more than a billion years?
- 2 Suppose that the electrical force was weaker than it is today. How would this change which heavier nuclei are stable? Would it have a similar effect on lighter nuclei?

## ANSWERS

- 1 If these half-lives were much shorter, then all the isotopes would have decayed away in the 4.5 billion years since the Earth was formed. There would be no radioactive isotopes left in the Earth's core or mantle to provide a continued source of heat to keep the interior of the Earth hot. The core would have cooled more quickly and might have become cold enough to solidify. Without a molten core, the Earth's magnetic field would be much smaller, and much more radiation would reach the surface in the form of **cosmic rays**. Continued radioactivity inside the planet helps protect against **cosmic radiation**.
- 2 If the electrical force were weaker, then there would be less electrical repulsion between protons. Therefore, heavy nuclei would need fewer extra neutrons to be stable. In the extreme case, where the electrical repulsion is negligible, heavy nuclei would have equal numbers of protons and neutrons, just like light nuclei. Weakening the electrical force would have much less effect on light nuclei, because the effect increases as the square of the number of protons.



# 02

## CURVE OF BINDING ENERGY: FISSION AND FUSION

**H**ow much energy does it take to break a nucleus into smaller pieces? This is measured by the **binding energy**, which shows up as a measurable change in the mass of the nucleus due to  $E = mc^2$ . The highest binding energy corresponds to the most stable nuclei. Iron and nickel are the most stable. This is different than the atomic density, where uranium is denser than lead, which is denser than iron. Iron is very stable and is the natural endpoint for **nucleosynthesis** in stars, so there is a lot of iron in the cores of rocky planets. ◆

## Nuclear Sizes

- ◆ The repulsion between atoms, or atom-atom repulsion—the force that keeps you from sinking through the floor—is due to the electromagnetic force and quantum mechanics. It's due to the Pauli exclusion principle and electron orbitals.
- ◆ Similarly, there is repulsion between protons and neutrons (nucleons). Nucleon-nucleon repulsion is due to the Pauli exclusion principle and quark orbitals. It gives us that the proton radius is a bit less than 1 fermi, or  $10^{-15}$  meters.
- ◆ Nuclear sizes were first measured crudely by Ernest Rutherford in his famous gold foil experiment with **alpha particles**, when he discovered the nucleus. But he really just found that the nucleus is very small. Now we can look at the diffraction patterns formed as we scatter very-short-wavelength electrons from them.
- ◆ How does diffraction work? We pass a laser through a narrow aperture, or slit, and look at the pattern of laser light on a screen. Diffraction patterns are due to the wave interference of the light. The narrower the slit, the wider the pattern. We can determine the width of the slit from the wavelength of the light and the spread of the pattern on the screen.
- ◆ How does this apply to electrons? Electrons are particles. But they're quantum mechanical particles, which means that they are waves, too. Like light, electrons travel as a wave but interact as a particle. Electrons can be diffracted by nuclei, just as light is diffracted by narrow slits.
- ◆ We need a wavelength that is similar in size to the nucleus, which is about 1 fermi. What energy is that? We need an energy of the electron that's 2000 times the mass energy of the electron. How can the energy be greater than  $mc^2$ ? If the electron's not moving, then its mass energy is  $mc^2$ . If it is moving, now it has both kinetic energy and mass energy.

And if the particle is moving at close to the speed of light ( $c$ ), the total energy—mass plus kinetic—can be much greater than just the mass energy.

- ◆ Short-wavelength, high-energy electrons passing around nuclei make diffraction patterns similar to light passing through a narrow slit. And just like light passing through a slit, we can determine the size of the nuclei by using the wavelength of the electrons, which we know, and the width of the diffraction pattern, which we can measure. The diffraction pattern turns out to be narrower for heavier nuclei, which means that they're bigger.
- ◆ We use the entire measured pattern, not just the minima, and some mathematical techniques to get the complete charge distribution—how much charge there is in each radius in the nucleus—and to figure out the precise charge radius.
- ◆ What do we learn from these nuclear charge distributions and radii? All nuclei have about the same density—number of protons and neutrons per cubic fermi—in the center. The difference is how big the central region is. Nuclear sizes increase much more slowly than the number of nucleons with mass.

Because of special relativity and  $E = mc^2$ , nuclear physics uses special units for mass and for energy.

For energy, we use the electron volt (eV), which is the charge of 1 electron or 1 proton passing through a potential difference of 1 volt.

So, we're going to measure energy in electron volts and mass in electron volts divided by the speed of light squared— $eV/c^2$ —because  $E = mc^2$ .

Electron volts is not always the best unit. Sometimes we want thousands of electron volts (keV), millions of electron volts (MeV), or billions of electron volts (GeV).

- ◆ For nuclei heavier than carbon, the volume increases as the number of nucleons. The radius increases as the cube root of the number of nucleons. This tells us that nucleons are incompressible. They stack like marbles, and we can picture nuclei crudely as balls of marbles.
- ◆ How does this compare to atoms? Electrons, as far as we know, have zero size. They're point particles, so you can't stack them like marbles. The distance of the closest electron to the nucleus is approximately  $1/Z$  (the number of protons). The distance of the farthest electron is approximately constant, because the other electrons screen out all but 1 proton's worth of that nuclear charge.
- ◆ The atomic size depends mostly on which column of the periodic table the atom is in, rather than how many electrons it has. On the other hand, the nuclear size depends primarily on mass, or the number of nucleons.

## Making Nuclei from Protons and Neutrons

- ◆ Now let's stick the marbles together and make nuclei from protons and neutrons. Which nucleon properties are important?
  - The mass of a proton or neutron is about 1 billion **electron volts** (GeV) divided by the speed of light squared:  $1 \text{ GeV}/c^2$ . Technically, the proton mass is  $0.9383 \text{ GeV}/c^2$ , while the neutron mass is slightly more,  $0.9396 \text{ GeV}/c^2$ . It's a small difference, but it is important for nuclear decay.
  - The **spin**, which is a kind of angular momentum, of a proton or neutron is  $\frac{1}{2}$ , and it can either be spin up ( $+\frac{1}{2}$ ) or spin down ( $-\frac{1}{2}$ ). The Pauli exclusion principle tells us that we can't have 2 protons in the same state, but spin allows 2 protons or neutrons in each state: 1 up and 1 down.

- The radius of a proton or neutron is a bit less than 1 fermi—about 0.9 fermi.
- ♦ The nuclei are bound by the interplay of the very-short-range attractive strong nuclear force—which has a range of only 1 or 2 fermis, so only nearby nucleons feel the force—and the weaker long-range electrical repulsion, which increases quadratically with proton number because every proton repels every other proton, so the number of repelling pairs is the number of protons times the number of protons minus 1:  $Z(Z - 1)$ .
- ♦ The strong force—sometimes described as a potential energy—is not a fundamental force. It is determined from measurements: proton-proton and proton-neutron collisions as well as the binding energy of [deuterium](#).
- ♦ The force between nucleons is very similar to the force between people: When we're far away from each other, there's no interaction. When we can get close, we can be attracted, and if we get too close, there can be a very strong repulsion. This is a complicated interaction. But there is a very small difference between the force on protons and the force on neutrons—called the isospin terms—so we can treat protons and neutrons almost identically.
- ♦ Nuclei prefer even numbers of protons and of neutrons, and they also prefer relatively equal number of protons and neutrons. The electromagnetic force is mostly the repulsion between the protons.
- ♦ With bigger nuclei, the nucleons feel that strong-force attraction only from their nearest neighbors. But the protons feel that electromagnetic repulsion from all the other protons, which means that bigger nuclei have proportionately more neutrons and are also less stable.

## Binding Energy

- ◆ The binding energy is the energy released when the nuclei or atoms are formed. It's the energy that must be supplied to disassemble the nuclei or atoms. For nuclei, the binding energy is the difference in mass energy between the total proton masses, plus the total neutron masses, minus the mass of the nucleus, times  $c^2$ :  $[Zm(^1\text{H}) + Nm_n - m(\text{nucleus})]c^2$ , so we have  $E = mc^2$ . This is also true of atomic and molecular binding energies, but those binding energies are much less than the mass of the electron. Nuclear binding energies are about 1% of the mass of the proton, so we see about a 1% change in mass.

- ◆ We measure binding energy indirectly, using a [mass spectrometer](#) to measure the mass precisely. We make an ion beam by stripping off the electrons from the atom, because then it's charged and much easier to accelerate. Then, we pass the atom through a velocity selector, which has an electric field and a magnetic field. The electric field makes the ions want to go up, while the magnetic force makes the ions want to go down. Only ions with just the right velocity—equal to the ratio of the electric and magnetic fields—go straight. The next step is to pass these ions with this specific velocity through a magnetic field.
- ◆ The magnetic field makes the ions go in circles, and by measuring the radius of the circle, we can measure the mass of the particle. The mass is proportional to the radius divided by the velocity:  $m \sim R/v$ .
- ◆ We also use magnetic fields to steer particles in accelerators and to measure the momentum of particles knocked out in nuclear collisions.

Batteries change mass as they charge—because they're gaining energy ( $E = mc^2$ ), so they're also gaining a little bit of mass—but the difference is too small to measure.

- ◆ We measure the radius of curvature by where the nucleus hits the detector. Usually, we also measure a known element so that we can get a more precise measurement. We make a spectrum and measure the masses by the locations of the peaks in the spectrum, and we measure the **abundance** of the different isotopes by the heights of those peaks.
- ◆ We can also use a mass spectrometer to separate isotopes—to get a pure sample of an isotope.
- ◆ Now that we can measure binding energies, we can plot the binding energies of the most stable isotope of each element. We plot the binding energy against the number of nuclei and get the **curve of binding energy**. Note that there's a very steep rise for light nuclei and a slow decrease for heavy nuclei.

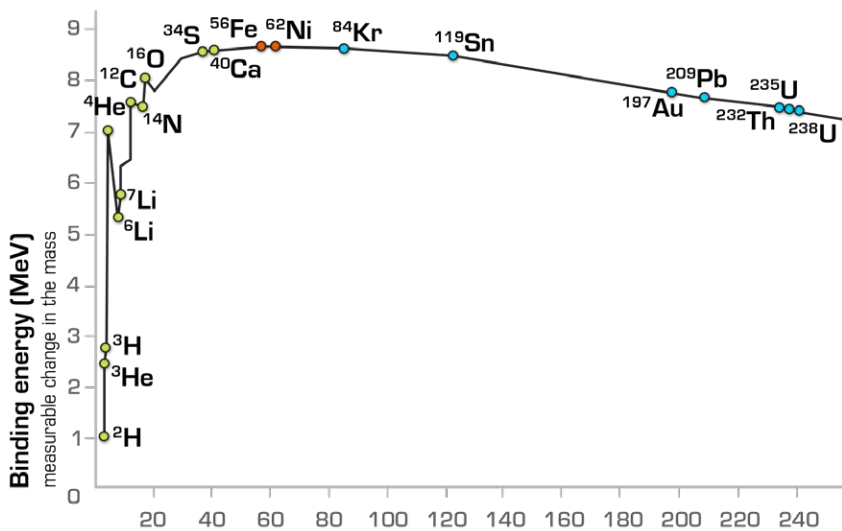

- ◆ Nuclei are made by smashing, or fusing, smaller nuclei—especially protons and sometimes helium-4—together. The big bang made hydrogen-2 (deuterium), helium-3, and helium-4. Helium, carbon, nitrogen, and oxygen are made in small stars. Larger stars make the elements up to iron, and supernovas or neutron-star mergers make the heavier elements.
- ◆ The shape of the curve of binding energy is determined by the interplay of electric repulsion and the strong nuclear force. The implication is that energy can be released by fusing lighter elements into heavier ones (up to iron). In the big bang, hydrogen was fused into heavy hydrogen (hydrogen-2, or deuterium), helium-3, and helium-4, and fusion provides the power source of stars. Energy can be released by fissioning heavier elements into lighter ones (down to iron), but that also implies that normal stars can't make heavier elements. We need other mechanisms.
- ◆ The shallowness of the curve of binding energy for very heavy nuclei means that we get less energy per nucleon from fission, and the steepness of the curve of binding energy for very light nuclei means that we get much more energy per nucleon from fusion. Overall, the shape of the curve of binding energy determines how we can get energy from nuclei, whether fission from heavy nuclei or fusion from light nuclei.



The heaviest naturally abundant nucleus is uranium. Uranium-238 has a half-life of 4.5 billion years—about the age of the Earth.

## Supplements

### READINGS

Lilley, *Nuclear Physics*, chap. 1.

Mackintosh, *Nucleus*, chaps. 4, 6, and 8.

Wiringa, “Evolution of Nuclear Spectra with Nuclear Forces.”

### QUESTIONS

- 1 We measure the nuclear binding energies of different isotopes by measuring their masses precisely and then converting the mass differences to the binding energies by using  $E = mc^2$ . Why don't we apply this same technique to measure the atomic (i.e., chemical) binding energies of different elements?
- 2 How much more energy can we gain by fusing 1 gram of hydrogen into helium than by fissioning 1 gram of uranium into lighter nuclei? What about fusing 4 hydrogen nuclei into 1 helium nucleus versus fissioning 1 uranium nucleus?

### ANSWERS

- 1 Nuclear binding energies are much larger than atomic binding energies. We can directly measure the masses of the different nuclei, from the proton (the nucleus of the hydrogen atom) to uranium and beyond. The difference between the mass of a nucleus and the total mass of the protons and neutrons that comprise it is about 1%, which is easily measurable. Atomic binding energies are thousands to millions of times smaller than nuclear binding energies. The mass differences corresponding to these tiny energies are difficult to impossible to measure directly.

2 We can release about 7 MeV of energy per nucleon by fusing hydrogen into helium but only about 1 MeV per nucleon by fissioning uranium into lighter nuclei. One gram of hydrogen is 1 mole, so it contains  $6 \times 10^{23}$  protons. One gram of uranium contains a lot fewer uranium nuclei, but it also contains about  $6 \times 10^{23}$  protons and neutrons. Therefore, fusing 1 gram of hydrogen will release about 7 times more energy than fissioning 1 gram of uranium.

However, fusing 4 hydrogen nuclei into 1 helium nucleus will release  $4 \times 7 \text{ MeV} = 28 \text{ MeV}$  of energy, but fissioning 1 uranium nucleus will release about  $238 \times 1 \text{ MeV} = 238 \text{ MeV}$  of energy.

Thus, nucleus for nucleus, uranium releases a lot more energy, but gram for gram, hydrogen releases more energy.



# 03

## ALPHA, BETA, AND GAMMA DECAY

**T**he term “radiation” may sound scary, but it refers to anything emitted—or radiated. We really only worry about radiation that breaks chemical bonds, called ionizing radiation. Radiation in the broader sense includes sound waves, gravitational waves, fast-moving subatomic particles from nuclear decay (alpha and beta particles and **gamma rays**), cosmic rays (mostly **muons**, the heavy cousins of the electron), particles emitted at accelerators and nuclear **reactors**, and all the other electromagnetic waves that have lower energies than x-rays and gamma rays. ◆

## Electromagnetic Waves and Radioactivity

- ◆ Electromagnetic waves are all basically the same; only the wavelength varies. They all travel like waves and interact like discrete particles. The energies of these particles, called photons, go as 1 over the wavelength:  $E = hc/\lambda$ . Long-wavelength electromagnetic waves have very-low-energy photons; short-wavelength electromagnetic waves have very-high-energy photons.
- ◆ Electromagnetic waves include radio waves, microwaves, and visible light—all of which have very-low-energy photons. Ultraviolet radiation has wavelengths from 10 to 400 nanometers; the typical ultraviolet photon energy is greater than 3 electron volts. X-rays have very short wavelengths on the order of nanometers; these photons have energies from about 1 to 300,000 electron volts. Gamma rays have even smaller wavelengths than x-rays; they have wavelengths that are shorter than  $1/100$  of a nanometer and energies above 300,000 electron volts.



The typical ultraviolet photon energy is greater than 3 electron volts, while the typical energy of a chemical bond is only about 1 electron volt, so ultraviolet photons are energetic enough to break chemical bonds and damage molecules. This is called sunburn.

- ◆ We worry about ionizing radiation. All radiation interacts in matter. When ionizing radiation interacts, it deposits enough energy to break chemical bonds. This weakens materials and damages DNA. Ionizing radiation includes x-rays, gamma rays, ultraviolet light, and fast-moving subatomic particles.
- ◆ Radioactivity is measured in disintegrations per time. There are 2 units for this measurement: the metric system unit, which is the **becquerel**, which is 1 disintegration per second; and the older unit that is still in wide use, called the **curie**, which is 40 billion disintegrations per second.
- ◆ Radioactive materials emit radiation via nuclear decay. Radiation is measured in particle flux: the number of particles per time, or the number per area per time. That is measured with a **Geiger counter**, which gives us counts per minute, which tells us the number of disintegrations per minute.
- ◆ Radiation is also measured in the amount that is absorbed in the exposed material. This is measured in terms of energy, in joules per kilogram. The unit for that is the **gray**, which is a metric system unit that is equal to 1 joule absorbed in a kilogram. The older unit, the **rad**, is 100 times smaller, so 100 rads would be 1 joule per kilogram of deposited energy.
- ◆ There is not much energy in a joule per kilogram. It is enough energy to lift 1 kilogram (a few pounds) by 10 centimeters (or 4 inches). If it were turned to heat, it would be less than a 1000<sup>th</sup> of a degree. But it can break a lot of chemical bonds, so it can do a lot of damage to the molecules in that material.

Whereas x-rays were called “x” because they were new and unknown, gamma rays were called “gamma,” the third letter of the Greek alphabet, because they were the third type of radiation discovered given off by radioactive decay.

- ◆ Different kinds of radiation have different biological effects. To measure the biological effects, we need to convert grays and rads, which are in joules per kilogram, to **rems** and **Sieverts**. We multiply the number of rads by a factor to get rems or the number of grays by a factor to get sieverts. The factor we use for beta and gamma radiation is 1. Alpha particles have a factor of 20; they deposit a lot of energy in a very small distance, so they break a lot of chemical bonds in a small region. Neutrons and protons are somewhere in between.

The banana equivalent dose is the amount of radiation that you get from eating a banana. It is  $1/10$  of a microsievert, or about 10 microrems. This is not used seriously, but it is used to show that there is radiation in the environment and that it does give us radiation.



## Nuclear Decay

- ◆ Half of the nuclei in a sample decay in 1 half-life. This is a statistical process; it's impossible to predict which specific nuclei will decay. If we just have 1 nucleus, we can't even tell when it will decay. A short half-life means that the nuclei are decaying very quickly and the material is very radioactive, but it is not going to stay radioactive for long. If there is a long half-life, the material is not very radioactive and will decay slowly; it will stay radioactive for a much longer time.

- ◆ Different isotopes have different half-lives. Nuclei that have too many protons or too many neutrons are moving away from the valley of stability.
- ◆ There are 3 main types of nuclear decay: alpha, beta, and gamma. All of these are emitted by radium and its decay products. They all behave differently in a magnetic field. When you pass them through a magnetic field, alpha particles are distributed one way, **beta particles** are deflected the other way, and gamma rays are not deflected—they go straight through. This tells us that alpha and beta particles have opposite charges and gamma rays are uncharged. Fission is a completely different process, and it's much rarer.
- ◆ The alpha particle, which is the nucleus of a helium atom, consists 2 protons and 2 neutrons very tightly bound together. That means that when you emit an alpha particle, because it conserves protons and neutrons, the total number of protons and the total number of neutrons have to be the same before and after. The daughter nucleus will have 2 fewer protons and 2 fewer neutron, so it will move 2 down and 2 to the left, on the chart of nuclides [PAGE 274].
- ◆ Why does the alpha particle decay and not emit a proton? Heavy nuclei are bound by about 8 million electron volts per nucleon, so to emit a proton, you have to find about 8 million electron volts. That's difficult. The alpha particle is already bound by 7 million electron volts per nucleon, so it is much easier to find the energy to emit an alpha particle.
- ◆ Alpha decay is due to the competition between electric repulsion and strong force attraction. Alpha decay conserves charge, so there are the same number of positive and negative charges before and after. It also conserves energy, so the difference in the binding energy, or mass energy, goes into the kinetic energy of the fragments.

- ◆ The difference in the binding energy is the mass of the parent nucleus, minus the mass of the daughter, minus the mass of the alpha particle, times  $c^2$ :  $Q = (m_A - m_B - m_\alpha)c^2$ . The bigger this difference is, the shorter the half-life. These differences range from 4 to 10 million electron volts, giving us half-lives ranging from 10 gigayears to 100 nanoseconds.
- ◆ Alpha decay also conserves momentum. There are only 2 particles in the final state: the daughter nucleus and the alpha particle. They have to have equal and opposite momenta. The alpha particle carries most of the kinetic energy, so it only has a single energy from a given decay. This energy is used to measure the **nuclear mass** differences between the parent nucleus and the daughter nucleus.
- ◆ Alpha decay is due to **quantum tunneling**. It's classically forbidden because the alpha particle is attracted to the center of the nucleus, and the electrical repulsion keeps it inside the nucleus. The alpha particle is quickly moving around and hitting the barrier of the nucleus at about  $10^{21}$  times per second until it quantum mechanically tunnels out.
- ◆ Inversely, if we aim an alpha particle at a nucleus and it doesn't have enough energy to overcome the electrical repulsion between the positively charged alpha particle and the positively charged nucleus, then it has to quantum mechanically tunnel in. And that, too, is unlikely. It takes a while to happen.
- ◆ How does tunneling work? We have a region where the wave function is decreasing exponentially because there is so much repulsion between the alpha particle and the rest of the protons, but we don't have the corresponding strong force attraction. The probability that the alpha particle is in the forbidden region decreases by a factor of 2 every 0.5 fermi. So, a small change in the energy of the alpha particle can make a huge change in the half-life of the nucleus.

- ◆ On the chart of nuclides, where the number of protons is plotted vertically and the number of neutrons is plotted horizontally, the stable isotopes are in black. The isotopes shown in yellow decay by alpha decay. They are heavier and have more protons.
- ◆ Beta radiation is caused by the weak nuclear force. There are 2 kinds of beta decay. If the particle is to the right or below the valley of stability, then it's going to have too many neutrons. The neutrons are going to decay to a proton, an electron, and an antineutrino. This is called beta-minus decay. As a neutron turns into a proton, the particle will move diagonally up and to the left on the chart of nuclides.
- ◆ If, on the other hand, the particle started with too many protons—meaning that it's to the left or above the valley of stability on the chart of nuclides—then the proton is going to decay to a neutron plus a positron and a neutrino. This is called beta-plus decay or positron emission. This particle will move diagonally down and to the right on the chart of nuclides as the proton turns into a neutron.
- ◆ Another way to change protons to neutrons is by electron conversion. When there are too many protons, a proton and an electron can combine via the weak force to make a neutron plus a neutrino. This particle moves one box diagonally down and to the right, and the total number of protons and neutrons is unchanged.
- ◆ The weak force conserves energy, momentum, charge, total number of protons and neutrons (but can change neutrons to protons), and number of electrons. In fact, it conserves the number of electron-like things called neutrinos that count like electrons. The number of electrons plus the number of neutrinos minus the number of positrons minus the number of antineutrinos is unchanged.

- ◆ The positron, or beta-plus particle, is the antiparticle of the electron, and it leaves the atomic weight unchanged. It makes an electron or a positron. If it makes an electron, it has to make an antineutrino, and if it makes a positron, it has to also make a neutrino.
- ◆ A neutrino has a tiny mass and no charge. Its existence was inferred from the fact that the energies of beta decay have a continuous spectrum of energy, unlike the alpha particles from alpha decay, that just have 1 energy. The alpha particle has a single energy because there are only 2 particles in the end: the daughter particle and the alpha particle. The electrons have a continuous spectrum because there have to be at least 3 particles involved. That third missing particle was hypothesized to be the neutrino. It was discovered a few decades later. We can also use the maximum energy of the electron to measure the nuclear binding energies.
- ◆ Weak decay is described by Fermi theory. There is no tunneling involved; it is just very weak. The probability has to do with the weakness of the weak force plus the similarity of the initial and final states of the nucleus.
- ◆ Gamma rays, or photons, are due to the electromagnetic force. There is no change in the number of neutrons, the number of protons, or the total number of nucleons. Most alpha and beta decays leave an excited daughter nucleus, which deexcites via gamma emission. The energies range from about 0.1 to 10 million electron volts (10 MeV).
- ◆ There are discrete energies that gamma rays give off that correspond to specific nuclei and specific nuclear states in those nuclei. This is just like an atom (when an electron changes orbit, it emits photons of a very specific wavelength of colors) or a nucleus (when a neutron or proton changes its orbit, it emits photons of a very specific energy).

- ◆ Blocking alpha and beta radiation from entering your body is not difficult and makes a big difference. Gamma radiation is always much more difficult to shield against. You have to have a barrier, such as lead, to stop the gamma rays or they will hit you.

## Supplements

### READINGS

- Jorgenson, *Strange Glow*.  
 Lilley, *Nuclear Physics*, chap. 3.  
 Mackintosh, *Nucleus*, chap. 2.  
 Rhodes, *The Making of the Atomic Bomb*.

### QUESTIONS

1 Radon is harmful, but how does it decay? The isotope commonly found in basements and mines is radon-222 (with 86 protons and 136 neutrons), which decays with a half-life of 3.8 days to polonium-218 (with 84 protons and 134 neutrons). Which decay process is responsible? And how difficult is it to shield against the decay products?

$^{222}\text{Ra}$	$^{223}\text{Ra}$	$^{224}\text{Ra}$	$^{225}\text{Ra}$	$^{226}\text{Ra}$
$^{221}\text{Fr}$	$^{222}\text{Fr}$	$^{223}\text{Fr}$	$^{224}\text{Fr}$	$^{225}\text{Fr}$
$^{220}\text{Rn}$	$^{221}\text{Rn}$	$^{222}\text{Rn}$	$^{223}\text{Rn}$	$^{224}\text{Rn}$
$^{219}\text{At}$	$^{220}\text{At}$	$^{221}\text{At}$	$^{222}\text{At}$	$^{223}\text{At}$
$^{218}\text{Po}$	$^{219}\text{Po}$	$^{220}\text{Po}$	$^{221}\text{Po}$	$^{222}\text{Po}$

2 Radon-223 (with 86 protons and 137 neutrons) decays by beta-minus decay. What is its daughter nucleus?

3 Fluorine-18 has 9 protons and 9 neutrons. It decays by beta-plus decay. What is its daughter nucleus?

4 Which is more dangerous: an isotope with a short half-life (e.g., carbon-11, with a half-life of 20 minutes) or with a long half-life (e.g., carbon-14, with a half-life of almost 6000 years)?

18Na	19Na	20Na	21Na	22Na
17Ne	18Ne	19Ne	20Ne	21Ne
16F	17F	18F	19F	20F
15O	16O	17O	18O	19O
14N	15N	16N	17N	18N

## ANSWERS

1 Because polonium-218 has 2 fewer protons and 2 fewer neutrons than radon-222, the decay occurs by emitting an alpha particle. Alpha particles have a very short range and are easily blocked by a layer of paper or dead skin. However, because radon is a gas, it can be inhaled, or it can contaminate a groundwater drinking supply. Once the radon is inside the body, the alpha particles will damage living tissue. Polonium-218 itself decays (with a half-life of 3 minutes) to lead-214, which also decays, leading to additional alpha and beta radiation. Radon-222 is the most common isotope of radon (the one that can accumulate in basements and in mines) because it is part of the uranium-238 decay chain.

2 The beta-minus decay will convert 1 neutron to 1 proton, emitting an electron (the “beta minus”) and an antineutrino. Therefore, the daughter nucleus will have 1 more proton and 1 fewer neutron, giving 87 protons, 136 neutrons, and the same 223 total nucleons. This nucleus is francium-223.

- 3 The beta-plus decay will convert 1 proton to 1 neutron, emitting a positron (the “beta plus”) and a neutrino. This will give a daughter nucleus with 8 protons and 10 neutrons. This nucleus is oxygen-18. Fluorine-18 is used for PET (**positron-emission tomography**) scans in nuclear medicine.
- 4 The material with the short half-life will be much more radioactive to begin with. For example, carbon-11 will be 100 million times more radioactive. However, the material with the short half-life will decay much faster, and its radioactivity will decrease much faster. For example, after 1 hour (3 half-lives), there will be  $2^3 = 8$  times less carbon-11. After 1 day, there will be  $8^{24} = 10^{21}$  times less carbon-11, so it will be negligibly radioactive. The carbon-14 will be 100 million times less radioactive than the carbon-11, but it will remain radioactive for 100 million times longer.



# 04

## RADIATION SOURCES, NATURAL AND UNNATURAL

**T**here are 3 main sources of radiation: terrestrial radiation, which comes from the decay of uranium and thorium, so is primarily natural; cosmic rays, which come from particles such as muons; and medical radiation, such as x-rays, **CT scans**, and nuclear medical procedures. The average dose of radiation that we get is about 600 millirem, or 6 millisieverts, per year. About half of that is natural background, about half is medical, and a few percent come from consumer products. About 2/3 of the natural **background radiation** comes from radon in the air. The other 1/3 comes from food and drink, including bananas; terrestrial radiation, usually from the uranium in the granite around us; and cosmic rays, which increase with altitude. ◆



The presence and intensity of radiation can be measured with a Geiger counter.

## Terrestrial Radiation

- ♦ Terrestrial radiation comes from the decay of uranium and thorium. Uranium-238 has a 4.5-billion-year half-life and decays by alpha decay. Thorium-232 has a 14-billion-year half-life and also decays by alpha decay.
- ♦ Uranium and thorium are present in many rocks. There is about 6 parts per million of thorium and 3 parts per million of uranium, so that gives us about 10 or 20 grams of thorium or uranium in every cubic meter of rock. These are about the only stable elements that are heavier than lead. They're not really stable, but they're stable enough—they have half-lives of billions of years. Their concentration is about a microcurie per cubic meter, which means we get very low radiation levels from thorium and uranium in granite.

- ◆ With thorium and uranium, there is a long chain of alpha and beta decays—turning neutrons to protons and moving down and to the right on the periodic table—that includes radon and terminates in lead for both. In both decay chains, about 50 million electron volts of energy is released in the form of radiation.

Radiation from cosmic rays is 50% greater in Denver than at sea level.

- ◆ The radioactive decay of uranium and thorium powers Earth's rock cycle, moves continents, and helps the core stay molten. How do we know this? First, we've dug deep holes, called bore holes, into the ground and measured how the **temperature** changes, and from that, we calculate that the core emits about 46 terawatts, or trillion watts, of power. In addition, we can calculate the expected decays from the abundances of those nuclei.
- ◆ We can also detect geoneutrinos from uranium and thorium decay, which tells us that there's about 20 terawatts of uranium and thorium decay—specifically, uranium-238 and thorium-232. There are also uranium-235 and potassium-40 decay, which give 4 more terawatts of energy, and 22 terawatts come from the residual heat of the core. The potassium-40 in Earth's core is what helps keep it molten and creates a magnetic field, which is crucial for cosmic-ray shielding.
- ◆ What makes radon special? Why do we get so much of our radiation from radon when it's just one of the uranium decay products? The other decay products are solids and stay put in the original rock. Radon is a noble gas—so it doesn't combine with anything—and it can migrate and concentrate in mines and in your basement.
- ◆ In addition, because it's a gas, we inhale it, which means that its alpha particles can do damage. The average dose of radiation from radon in the United States is about 230 millirem per year. Also, radon dissolves in water, so we can inhale radon gas when showering. And the decay products of radon become dust and then become inhalable.

- ◆ The concentration of radon varies widely with region and geology. It is greater in hilly and mountainous terrain. It's also 8 times less dangerous for nonsmokers than for smokers. And it's not present in submarines.
- ◆ How else do uranium and thorium irradiate us? The decay products—the elements in the uranium and thorium decay chains—in rock emit gamma rays. Alpha and beta particles can't escape the rock, but we do get about 21 millirem per year average in the United States. This is widely variable and ranges from about 10 to 100 millirem per year.

## Cosmic Rays

- ◆ Did you know that hundreds of cosmic rays pass through you every second? If you hold out your hand, there's 1 cosmic ray passing through your hand every second.
- ◆ Cosmic rays start out as high-energy nuclei—mostly protons (90%), but some alpha particles (9%)—that hit the upper atmosphere. These particles react with air nuclei, making showers of particles, including pions, protons, and neutrons.
- ◆ The protons, neutrons, and pions interact via the strong nuclear force, so they interact a lot. And they don't reach the ground. We don't care about the neutrinos; they're not going to interact. The particles that are left are muons, which come from the decay of pions and are the heavy cousins of the electron. They have a positive charge and a negative charge, but they have a very short lifetime: only 2.2 microseconds, or millionths of a second.
- ◆ In addition, when these high-energy cosmic rays interact with the atoms in the atmosphere, they can change them. For example, they can interact with nitrogen-14 and turn it into carbon-14. They can also make other radioisotopes in the atmosphere.

- ◆ The muons are the only ones that reach the ground. How many muons are there? There are  $10^4$  per square meter per second, which is about 1 per hand per second, mostly coming down from above. For our whole body, we get about  $10^4$  per second, which is comparable to what we'd get if we held a microcurie radioactive source in our hand.
- ◆ Why do we care that the Earth has a magnetic field? It deflects cosmic rays from hitting the atmosphere. That means that fewer of these high-energy charged particles actually hit the Earth's atmosphere. Instead, they form the Van Allen radiation belts, which are about 600 to 60,000 kilometers from the Earth and are due to cosmic rays being trapped by the magnetic field. The Van Allen belts are dangerous to humans and satellites.
- ◆ At the North and South Pole, the magnetic field is almost vertical, which means that cosmic rays can reach the surface of the Earth much more easily in these areas than at the equator. That's why we have the aurora; the high-energy charged particles excite atoms in the air and make those colors.
- ◆ Astronauts that are outside the Earth's magnetic field see flashes of light associated with cosmic rays passing through their eyes. We don't know exactly how this works, but it's definitely seen.



The amount of medical radiation has increased dramatically, although it is variable from person to person. In 1987, only 15% of the radiation we received was from medical purposes, such as CT scans and x-rays; by 2017, this number was close to 50%.

## Other Radiation Sources

- ◆ Uranium fission, not just decay, creates very radioactive by-products. Radiation exposure from bomb test fallout and from nuclear power plants is less than 1% of our exposure today. Bomb test fallout decays and leaves the atmosphere, and nuclear power plants in normal operation emit almost no radiation.
- ◆ Some consumer products contribute to our radiation exposure. For example, smoke detectors contain americium, which is an alpha emitter used to ionize the air to help us measure whether there's smoke present. And alpha particles have a very short range; they don't escape the container.
- ◆ Another source of radiation is gaseous **tritium** light sources. Tritium, which is heavy hydrogen (with 1 proton and 2 neutrons), has about a 10-year half-life. A gas tube containing tritium is coated on the inside with a phosphorescent chemical. (These are the same kinds of phosphors that were used in old cathode ray television sets.) The beta decay from tritium (electron) hits phosphor, which emits light. It's only an 18-kilovolt electron, so it can't penetrate the tube. The color of the light has nothing to do with the radiation; it's due to the choice of the phosphor. It's used in exit lighting, watch dials, compasses, and gun sights.
- ◆ There are also some old products that contain radiation. Orange Fiesta ware glaze, used on dinnerware, contains uranium oxide. The uranium for this was confiscated in World War II, so it stopped being made during the war. In 1959, producers switched to **depleted uranium**, so it's much less radioactive, but it still contains uranium. The old product is much more radioactive.
- ◆ Radiation used to be good for us—or that's what we thought—so it was used in a number of ways. From the 1920s to the 1950s, shoe fluoroscopy was used in shoe stores. X-rays were shined through shoes

and feet, onto a fluorescent screen, which was much less sensitive than film. A shoe fluoroscope had 3 viewing ports so that the salesperson and customer could directly see how well the shoe fit: how the bones of the feet fit inside the shoe. The problem is, for a 20-second view, you got a radiation dose of about 10 rem—a huge dose. There were no reported injuries to customers, but there was at least one shoe model who needed her leg amputated.

- ◆ In addition, radium-infused carbon dioxide cartridges could be used to make soda at home. There was also radithor, which is radium dissolved in water. A case of bottles sold for 10 times the cost of radium.
- ◆ Radium is known as a bone seeker, or an element that accumulates in the bones when added to the body. It was thought to be beneficial, and warnings were disregarded. Fortunately, about 95% of the radium products were frauds; only the wealthy could afford the real stuff.
- ◆ Radioactivity was also used to power pacemakers. They used the heat from radioactive decay to generate an electric current using a thermocouple. They used plutonium-238, an isotope of plutonium with a half-life of 90 years. It emits a 5-million-electron-volt alpha particle and puts out about half a watt per gram of plutonium. Radiation can't penetrate the pacemaker, so there's no danger from the radiation leaving the pacemaker.
- ◆ The plutonium pacemaker was used because it never needs new batteries, because the half-life of plutonium is longer than the half-life of the patient. It used a lot of plutonium: 5 curies per patient. Plutonium was used in pacemakers from 1973 to 1988, when people realized that cremating radioactive pacemakers would be bad and when 10-year lithium batteries became available.
- ◆ The same technology is still used to power remote lighthouses and NASA deep space missions. *Pioneer*, *Voyager*, *Cassini*, and *Viking* all used radioisotope thermal generators to generate long-term power.

## Supplements

### READINGS

Bolus, “NCRP Report 160 and What It Means for Medical Imaging and Nuclear Medicine.”

Jorgenson, *Strange Glow*.

National Council on Radiation Protection and Measurements, *Report No. 160*.

National Research Council, *Health Risks from Exposure to Low Levels of Ionizing Radiation*.

Rhodes, *The Making of the Atomic Bomb*.

The KamLAND Collaboration, “Partial Radiogenic Heat Model for Earth Revealed by Geoneutrino Measurements.”

### QUESTIONS

- 1 The average background radiation received in the United States is about 600 millirems (mrem) per year. Why is this average number misleading for calculating your own exposure?
- 2 How much more radiation would we receive if we ate all of our meals on prewar orange Fiestaware?

### ANSWERS

- 1 Half of this average number (300 mrem/year) comes from medical radiation used for diagnostic purposes. If you do not have any x-rays, CT scans, or PET or SPECT scans, then your radiation dose is only 300 mrem/year. If you do get a CT, PET, or SPECT scan, then you can receive from 100 to 1000 mrem per scan. In addition,  $\frac{2}{3}$  of nonmedical radiation (200 mrem/year) comes from radon (mostly radon trapped in basements). This also varies dramatically with location—from almost nothing to

1000 mrem, depending on soil composition and basement ventilation. Thus, if you live in a low-radon area and did not receive medical radiation, your yearly radiation dose could be as low as 100 mrem.

2 When we measured the radioactivity of the Fiestaware plate in the video lecture, we saw that the Geiger counter counted about 100 times faster than for cosmic rays. We receive about 30 mrem per year from cosmic rays. We will get about 100 times more than that from the Fiestaware, but only the parts of our body close to the plates will get irradiated (about 20%), and we are only near it during meals (i.e., about 10% of the time). Thus, the whole-body radiation dose would be about  $30 \text{ mrem/year} \times 100 \times 0.2 \times 0.1 = 60 \text{ mrem/year}$ . If we also drink from an orange Fiestaware teacup, we have to include the very-short-ranged beta radiation, which would give an additional yearly dose of 400 mrem to the lips and 1200 mrem to the fingers. For more information, see <http://www.ornl.gov/ptp/collection/consumer%20products/fiesta.htm>.



# 05

## HOW DANGEROUS IS RADIATION?

**R**adiation is scary because it's invisible and its effects are invisible. People were equally scared of electricity 100 years ago; newspapers avidly reported every accidental electrocution from the tangle of dangling wires that ran across city streets. Like electricity, radiation is a very useful tool. Unlike electricity, if radiation escapes, it can harm a lot of people at the same time. Fortunately, it only hurts people in rare circumstances. ◆

## How Particles Interact with Matter

- ◆ Radiation damages cells by knocking loose the electrons that form chemical bonds and by breaking apart molecules. The energies of these particles are measured in thousands to millions or billions of electron volts. The chemical bond energies are measured in only electron volts.
- ◆ Charged particles interact with the atomic electrons in the material they pass through, exciting them to higher-energy states or knocking them loose. Electrons, beta-minus particles, are very light. They knock out fewer atomic electrons in one place, so it's easier for molecules to recombine or for the body to repair them.
- ◆ Heavier particles, such as alpha particles or protons, knock a lot of electrons loose. They're short-ranged, so they deposit a lot of energy in a short distance, ionizing a lot of atoms or molecules in the same place.
- ◆ Neutrons aren't charged. High-energy neutrons lose energy through collisions. A high-energy neutron could elastically scatter with a proton in one of the nuclei and knock the protons out so that they transfer their energy to a proton. The proton can then transfer its energy to atomic electrons. Low-energy neutrons can combine with a proton in a hydrogen nucleus to make a deuterium nucleus and give off a 2-million-electron volt photon: a gamma ray.
- ◆ Photons, such as x-rays and gamma rays, interact discretely—in individual collisions. They can transfer a lot of energy to a single electron through a few processes.
  - 1 The photon can collide with 1 electron. The photon bounces off of the electron in a process called Compton scattering, which is dominant in tissue in the body.
  - 2 The photon can be absorbed on an atom, followed by emitting an electron from it. This is called the photoelectric effect.

- 3 If the photon is very high in energy, it can turn into an electron plus a positron in a process called **pair production**. This is important at higher energies for particle detectors called shower counters. The energetic electrons that were knocked out then interact with the atomic electrons.
- ◆ Which type of radiation is worse? There is a biological weighting factor that depends on the ionization density: How many atoms and molecules are disrupted in a tiny space? The more energy that is deposited in a small region leads to a lot more damage in that region, and that is much more difficult to repair. The electrons and the photons, or gamma rays, that knock out other electrons have a very low weight. They have a weight of just 1. But low-energy electrons, beta rays, are stopped by the skin and give something called beta burns because they deposit all of their energy there. Gamma rays just keep going and going.
  - ◆ The other particles have higher biological weighting factors. Protons have a weighting factor of about 5. The weighting factor for neutrons is between 5 and 20, depending on their energy. And alpha particles, because they deposit so much energy in such a small space, have a weighting factor of 20. Multiply the dose in rads by the weighting factor to get rems. Or, to get radiation in metric system units, multiply the absorbed dose in grays by the correction factor to get sieverts.

## Chemical Bonds

- ◆ Which chemical bonds are important? DNA is the big important molecule that's critical to the functioning of our cells. The other bonds are important indirectly. Free radicals can be made. If some radiation interacts with a water molecule, it can knock an electron loose, creating a positively charged water molecule ion and an electron. Then, the electron gets absorbed in another water molecule, making a negatively charged water molecule. These water molecule ions can disassociate to

form OH and H free radicals. There are also some other free radicals: HO<sub>2</sub> and H<sub>2</sub>O<sub>2</sub>. And oxygen enhances this effect. These free radicals can then react with and disrupt other molecules, including DNA.

- ◆ The DNA in dividing cells is the most vulnerable because DNA in a regular cell is all coiled up. But when the cell divides, the DNA uncoils and is exposed. The cells that divide quickly are in lymph nodes, sperm, bone marrow, and the intestine. Children also have much more cell division during growth.
- ◆ The damage does not always kill the cell. There are many other ways that cells can be damaged, besides radiation, so they have repair mechanisms. There are 2 possibilities: The repair can succeed—now the cell is fine—or the repair can fail. If the repair fails, there are again a few possibilities: cell death, which only becomes a problem if many cells die at the same time; somatic effects, where something changes in the cell and can lead to cancer; and genetic effects, which are very rare.
- ◆ Not all radiation is dangerous. Only ionizing radiation—which can ionize atoms and break the chemical bonds—is dangerous. Nonionizing radiation doesn't break chemical bonds. This includes radiation from cell phones. There have been some contradictory case control studies, but 2 large cohort studies both found that cell phones had no effect on brain cancer. More importantly, there has been no change in the brain cancer incidents in the United States in 40 years as cell phone usage has grown dramatically.

The World Health Organization lists cell phones as a “possible carcinogen,” but that list also includes aloe, coffee, and talc—so it's a very low bar.

- ◆ Power lines emit 60 hertz of electromagnetic radiation. These are very-low-frequency radio waves. There were some scary magazine articles about radiation from power lines, but there's no real evidence of any damage. Large-scale studies show that there is, in fact, no damage from power lines.

- ◆ A microwave typically puts out about 1 kilowatt of power, which in 1 second just raises body temperature by a hundredth of a degree Fahrenheit. On the other hand, 1 kilowatt of ionizing radiation could kill a person in 1 second. So, a microwave is 1000 times less dangerous than ionizing radiation. Although, if it's on too long, the heat can be dangerous.

## Doses of Radiation

- ◆ With ionizing radiation, we can get the radiation all at once, which is an **acute dose**, or we can get it over a period of time, which is a **chronic dose**.
- ◆ A single large dose of ionizing radiation is called acute radiation syndrome. It kills lots of cells all at once, especially the fast-dividing ones.
  - If the dose is less than 100 rem, or 1 sievert, there are generally no symptoms.
  - From 100 to 200 rems, or 1 to 2 sieverts, there is typically nausea and vomiting and fatigue, and some white blood cells are killed.
  - From 200 to 600 rem, or 2 to 6 sieverts, there are the same symptoms—although more severe—plus headache, confusion, fever, hair loss, hemorrhage, and infections. And it leads to a 50% death rate in about 4 to 6 weeks.
  - From 600 to 800 rem, or 6 to 8 sieverts, there are the same symptoms plus diarrhea and major system failure. About 95% of people will die without care, and 50% to 100% die even with care.

- Above 800 rem is fatal. But that's more than 1000 times the average yearly dose all in a very short period of time.
- ♦ To treat radiation poisoning, we first decontaminate the outside of the patient by changing their clothing and washing off any radiation on the outside by showering them. Then, we can try to decontaminate the inside of the patient. This includes chelation therapy for heavy metals as well as “acceleration of the metabolic cycle of the radionuclide by isotope dilution.” If you're exposed to radioactive iodine, take a potassium iodide tablet so that the nonradioactive iodine from the potassium iodide will replace some of the radioactive iodine. If you're exposed to tritium, drink lots of beer to flush out the radioactive hydrogen.
- ♦ What should you do if a **nuclear bomb** or a **dirty bomb** goes off?
  - A dirty bomb is a conventional explosive that distributes specific isotopes from something like a stolen radioactive source. Not much radiation is released; it's more scary than harmful. You should cover your mouth and nose, go inside, remove potentially contaminated clothes and bag them, and shower.
  - If a nuclear bomb goes off, there is a lot of direct radiation and fallout from the fission isotopes. The wind can carry radioactive fallout large distances. Assuming that you survive the blast and the fire effects, which are much worse than the radiation, there will have been lots of neutrons and gamma radiation. First, find shelter; go inside as soon as possible. Then, wash off any fallout by taking a shower. Remove potentially contaminated clothes and bag them. Only take iodine tablets if recommended by the health authorities, because iodine tablets have side effects and you can overdose on them. Finally, manage the symptoms: Treat shock, give blood transfusions, give fluids, and give antiemetics to reduce nausea and vomiting.

- ◆ If the radiation doesn't kill or sicken the person quickly, then it is considered a chronic dose. For example, radioactive iodine-131 from nuclear fallout concentrates in the thyroid and can cause cancer. The half-life of the iodine is only 8 days, and after about 10 half-lives, or 80 days, it's pretty much all gone. Thyroid cancers have been seen in nuclear bomb survivors and **Chernobyl** victims.
- ◆ Leukemia is another common radiation-caused cancer. It is seen in islanders near Pacific atoll bomb tests. It's slightly elevated among radiation workers, and it's also seen in Hiroshima survivors. Unlike thyroid cancer, it's not clear if leukemia is caused by a specific isotope.
- ◆ By conservative estimates, there's about a 0.05% extra chance in a lifetime per rem of radiation received of developing extra cancers. With 100 rem of extra radiation as a lifetime dose, that implies a 5% extra chance of getting cancer.
- ◆ What about the long-term effects from the more than 500 above-ground bomb tests that were ended around 1963? There are some local effects where the bomb fallout was the densest. There is more carbon-14 in the atmosphere, but that's in parts per trillion, and this carbon-14 change is actually a useful dating tool.
- ◆ We have good data at high doses of radiation, but there's poor data at low doses of radiation. There are big uncertainties in the effects at low doses because we expect the effects to be small, and therefore they are difficult to measure.
- ◆ Mutations are caused by damage to sperm or egg cells, show up in the next generation, and are rarely beneficial. About 100 rem doubles the natural mutation rate in mice. There are no measurable mutations above the natural background rate of mutations in nuclear bomb survivors' children. One reason for that is there were too few survivors who received high doses to see an effect. Fortunately, there's not enough data on humans, so we use the mouse data.

- ◆ Radiation dose limits only apply to power plants and other nonmedical sources. The average background radiation of 0.6 rem per year—half of which comes from natural sources and half of which comes from medical procedures—is not included. Medical radiation is not included because the benefit of the test should dramatically outweigh the harm done from receiving the extra radiation.
- ◆ The radiation worker limits are 50 millisieverts, or 5 rem, per year. Limits for the general public are 1 millisievert, or 0.1 rem, per year. It took a while to realize that radium is harmful because the effects were so delayed and because people had to correlate the different cases of radium poisoning to figure out their common cause.



The EPA standard for homes is that if a smoker lives for 75 years in the same home, there is a 6% elevated lifetime cancer risk. The EPA says that radon is the number 2 cause of lung cancer, after smoking. And if a smoker has radon exposure, it's 10 times more dangerous to them than for a nonsmoker.



## How much life do we lose for each activity that we do?

- Smokers will lose 2400 days, or about 6.5 years, of life.
  - People who are 20% overweight will lose about 1000 days of life, which is almost 3 years.
  - People who work in agriculture, construction, and mining are more susceptible to accidents and will lose somewhere between half of a year and a year of life.
  - Driving, on average, costs each of us about half of a year of life.
  - If we get an extra 300 millirem per year of radiation throughout our lives, that will cost us 10 times less than driving, or about 15 days of life.
- 
- ♦ Other occupational exposures include early radiation scientists, such as Thomas Edison, Henri Becquerel, and Marie Curie; dentists, who used to hold x-ray film in their hands; and miners, who were exposed to radon down in the mines. There is also radon in homes.
  - ♦ There are studies of nuclear accident survivors and of Hiroshima and Nagasaki survivors. A prospective long-term cohort study called the Life Span Study, which was originally intended to look for the extra mutations caused by the nuclear bombings, found that there was only 5% more cancer among survivors who were exposed to radiation. There were no measurable genetic effects—no mutations—above the natural incidence of cancer.

- ◆ Human cancer risk is very variable, and low-dose radiation effects are small. There are 2 opposite ideas of low-dose effects. The first is the radiation hormesis hypothesis, which is that small doses of radiation stimulate cellular repair mechanisms and are therefore good for you. This is not widely accepted. The second is the linear no-threshold hypothesis, which assumes that there is no “safe” dose of radiation. We don’t know if this is reasonable, but we use this hypothesis because it’s the most conservative one for radiation regulation.

## Supplements

### READINGS

Jorgenson, *Strange Glow*.

National Research Council, *Health Risks from Exposure to Low Levels of Ionizing Radiation*.

Rhodes, *The Making of the Atomic Bomb*.

### QUESTIONS

- 1 Could an astronaut traveling to Mars die from exposure to cosmic radiation during the trip? On Earth, the radiation dose from cosmic rays is roughly 30 millirems (mrem) per year, but in space an astronaut would receive 1000 times more radiation, or 30 rem per year.
- 2 A 1-rem CT scan is estimated to increase our chance of premature death by 0.05%. How many miles would we need to drive to incur the same risk?

## ANSWERS

1 A trip from the Earth to Mars will take about 6 months. The radiation dose from cosmic rays on Earth is only about 30 mrem/year because most of the cosmic rays are deflected by the Earth's magnetic fields and most of the remainder are blocked by the Earth's atmosphere. A mission to Mars will travel both outside the atmosphere (like the International Space Station) and beyond the protection of the Earth's magnetic fields. At 30 rem/year, an astronaut will receive 15 rem in the 6-month voyage. This is well below the 100-rem threshold for acute radiation syndrome but will increase the astronaut's lifetime probability of getting cancer by about 2%. The biggest unknown is the effect of solar storms, which can emit large quantities of radiation and could be quite dangerous.

2 Driving is dangerous. There is 1 extra death for every 100 million miles driven. To get an extra 0.05% of a death ( $5 \times 10^{-4}$ ), we would need to drive  $(5 \times 10^{-4})(10^8) = (5 \times 10^4)$  miles, or 50,000 miles. That is about 4 years of driving.





# 06

## THE LIQUID-DROP MODEL OF THE NUCLEUS

**T**he nucleus of the atom behaves approximately like a droplet of water. Individual protons and neutrons are like solid marbles, but enough marbles together can flow like water—just like flowing sand. The **liquid-drop model**, which was developed in the late 1930s, describes a lot of the nuclear masses. The curve of binding energy just includes the most stable isotope for each element. This lecture will offer a way to describe the masses of all the isotopes. ◆

## Isotopes and Isotones

- ◆ The simplest atom is a hydrogen atom. It has 1 electron interacting with 1 proton. They interact via the electric and magnetic forces. The hydrogen atom has lots of excited states corresponding to lots of emission and absorption lines. We measure the energies of those lines, and that gives us lots of information about how the electron and proton interact with each other.
- ◆ The simplest nontrivial nucleus has 1 proton interacting with 1 neutron. This is the **deuteron**, sometimes called deuterium, and it's the isotope of hydrogen. The deuteron only has one state—the bound state—so we can't learn quite as much about the nucleon-nucleon interaction from studying the deuteron. There are no stable nuclei with 2 protons or with 2 neutrons.
- ◆ What can we learn from the deuteron? We can learn about the binding energy, which is measured using a mass spectrometer. We compare the mass of deuterium with the mass of hydrogen. We can also look at the reaction of when a neutron hits a proton at low energies; they stick together to form a deuteron and give off a gamma ray. We can also look at the inverse reaction: We can aim gamma rays at deuterium and detect the neutron and proton that come out.
- ◆ We find that the deuteron is barely bound. The binding energy is 2.2 million electron volts, which means that the potential energy of the system is very large and the kinetic energy is almost as big. When you add the 2 together, the positive kinetic energy almost equals the negative potential energy. This is very different in an atomic or gravitational system, where the potential energy is about twice as big as the kinetic energy. The radius of deuterium is also fairly large, at 2.1 fermis, or femtometers.

- ◆ Angular momentum measures how much an object rotates. It is one of the basic conserved quantities in the universe: We know that charge, energy, and momentum are conserved. Angular momentum is also one of the fundamental attributes of particles.
- ◆ There are 2 types of angular momentum. The first is spin, which is the intrinsic angular momentum that belongs to a particle. Most **elementary particles** spin like a top, and the spin is quantized, which means that it can only have certain specific values. The proton and the neutron each have a spin of  $\frac{1}{2}$ . Spin can either be down, which means that it's spinning clockwise, or up, which means that it's spinning counterclockwise. The nucleon-nucleon interaction (the force between 2 nucleons) depends on the alignments of their spins—whether their spin is in the same direction or in opposite directions.
- ◆ The second type is orbital angular momentum. The nucleons can orbit each other like the Moon orbits the Earth. Orbital angular momentum is also quantized; it can only have values of 0, 1, 2, etc. The total angular momentum is the orbital angular momentum combined with spin angular momentum.
- ◆ How does spin affect the shape of the deuteron? The proton and neutron spins are aligned—they're both spinning in the same direction—so the total spin is  $\frac{1}{2}$  plus  $\frac{1}{2}$ , which is equal to 1. The total angular momentum of the deuteron is 1. That means that there are 2 possibilities: either orbital angular momentum is 0 (*s* state), where the neutron and the proton are apart from each other; or orbital angular momentum is 2 (*d* state), where the neutron and the proton are orbiting each other.
- ◆ What about 2 protons or 2 neutrons? Nucleons are particles that can't occupy the same state; they obey the Pauli exclusion principle. A neutron is different from a proton, so each can have the same spin,

such as spin up. But if you have 2 protons (or 2 neutrons), those are the same particles, so they have to have different spin. The problem is that the nucleon-nucleon force is slightly weaker for different spin. The 2 protons repel each other, and this makes them more unbound than 2 neutrons because it's more difficult for 2 protons to form a nucleus than 2 neutrons.

- ◆ How are heavier nuclei affected by changing the number of protons ( $Z$ ) and neutrons ( $N$ )? We have isotopes with the same number of protons and different neutrons. Isotopes with the same number of protons are the same element. As we add neutrons, the nuclei become less bound and less stable and have shorter half-lives. Those extra neutrons are going to beta-decay to a proton and electron and an antineutrino. If there are way too many neutrons, then they don't wait around for beta decay; instead, they drip off.
- ◆ If instead we subtract neutrons, the nuclei also become less bound and less stable and have shorter half-lives. But in this case, the protons will beta-plus decay to a neutron, a positron, and a neutrino. Or the proton might absorb an electron—called electron conversion—to become a neutron plus a neutrino. And just like with neutrons, if there are way too many protons, they don't wait around for beta decay and instead just drip off.
- ◆ When we add or subtract protons, we have an **isotope**, which has a fixed number of neutrons and a different number of protons and therefore is a different element.

$Z$  represents the number of protons and  $N$  represents the number of neutrons.  $Z$  comes from the German word *zahl*, which means number.

## Charting Protons and Neutrons

- ◆ The chart of nuclides [PAGE 274] shows all of the combinations of protons and neutrons. There is a very narrow band of stable nuclei. Often there is just 1 stable isotope, especially for odd-even nuclei, and frequently there are no stable isotones. There is also a narrow band of known nuclei. There is a lot of space on the chart that is not filled; this represents nuclei that are either not known or, in most cases, impossible.
- ◆ With light nuclei, the number of neutrons is about equal to the number of protons. This is represented on the chart of nuclides by a  $45^\circ$  line, starting at the bottom left and moving up and to the right. With heavy nuclei, there are more neutrons than protons—the ratio is about 1.5—so that  $45^\circ$  line bends over. This is because we need more neutrons to offset the repulsion among all the protons.
- ◆ Also on the chart of nuclides are magic numbers that show us where there are more stable isotopes or isotones. There are very few stable nuclei with an odd number of protons and an odd number of neutrons, ranging from deuterium, with 1 proton and 1 neutron, up to tantalum-180.
- ◆ There are no stable nuclei with more than 82 protons—that's lead. Bismuth-209 is close, but it's unstable; the half-life is greater than the age of the universe. Is there an island of stability, or relative stability, at some larger magic number that we haven't discovered yet?
- ◆ The stable nuclei form a valley of stability. The nuclei decay toward the valley. If the nuclei have too many protons, then they're going to beta-plus decay down toward the valley. If there are too many neutrons, then they are going to beta-minus decay down toward the valley. And if there are way too many protons or neutrons, then those excess protons or neutrons just drip off. These are the drip lines. We know where the proton drip lines are, but we don't know where the neutron drip lines are. And there are still more nuclei to discover.

## Systematizing Binding Energy

- ◆ How can we describe the curve of binding energy and the isotopes and isotones? We know that the binding energy per nucleon is almost constant for heavy nuclei. For all nuclei heavier than carbon, the binding energy is about the same: 7 to 8 MeV. Therefore, we can use a volume term proportional to the number of nucleons, which will be some number times the number of nucleons:  $a_v A$ .
- ◆ This implies that each nucleon is only attracted to its closest neighbors. Note that this is not true for atoms, because the binding energies for electrons in atoms is not constant. It increases proportional to the square of the number of protons, not just the number of protons.
- ◆ What about the nucleons on the surface? Nucleons are attracted to their nearest neighbor. Surface nucleons have fewer neighbors, so they're less bound, just like in a water droplet. The effect is bigger in smaller nuclei because smaller nuclei have more surface relative to volume.
- ◆ This is not precise for light nuclei; it does not give us the wiggles and peaks in the curve of binding energy, but it gives us the general shape. This is similar to surface tension in liquids: Water droplets bead up to minimize their surface area. The same thing happens with nuclei.
- ◆ The surface area of a sphere,  $4\pi r^2$ , is a radius squared. The radius of a nucleus is about the cube root of the number of nucleons, so the radius squared is a number of nucleons to the  $2/3$  power:  $A^{2/3}$ . We'll add a negative term (some number) times the number of nucleons to the  $2/3$  power to get the surface energy:  $-a_s A^{2/3}$ .
- ◆ We also want to include the electrical repulsion between the protons because that makes a nucleus less bound. Every proton repels every other proton, so if we have  $Z$  protons, each of those protons has  $(Z - 1)$  other protons, so we'll multiply  $Z$  times  $(Z - 1)$  times another number:  $-a_c Z(Z - 1)$ .

- ◆ We're going to add more terms to fit the data better. These are not motivated by just water droplets; they are added to describe the behavior of the nuclei that we can see. And we can tell that nuclei prefer to have the same number of protons and neutrons, so we're going to take the number of neutrons minus the number of protons and square it to deal with the problem of having too many neutrons or too many protons. This is divided by the total number of nucleons:  $-a_{\text{sym}}(N - Z)^2/A$ . This is less important for stable nuclei with increasing atomic number, but it describes the valley of stability very nicely.
- ◆ There is also a pairing term. Recall that there are very few stable odd-odd nuclei. It turns out that nuclei prefer to have an even number of protons and an even number of neutrons, so we'll add a term that gives a bonus to even-even nuclei ( $+a_p A^{-3/8}$ ), a 0 for even-odd nuclei, and a penalty for odd-odd nuclei ( $-a_p A^{-3/8}$ ).
- ◆ We now have 5 parameters, and we're going to fit them to the binding energy data to give us the best description of the data:

Energy = volume – surface – proton  
repulsion – asymmetry + pairing

$$E = a_v A - a_s A^{2/3} - a_c Z(Z - 1) - a_{\text{sym}}(N - Z)^2/A + \text{pairing term}$$

- ◆ Nucleons inside the volume of the nucleus all interact with their nearest neighbors, which gives us the volume term. Nucleons on the surface have fewer neighbors and are therefore less bound. Every proton repels every other proton, giving a negative term proportional to the square of the number of protons. Nuclei prefer to have equal numbers of protons and neutrons, and this gives us the asymmetry term. Lastly, nuclei prefer to have even numbers of protons and of neutrons.
- ◆ The surface term explains a dramatic rise in the curve of binding energy for light nuclei. The electrical repulsion and asymmetry terms explain the slow decrease in the curve of binding energy for heavy nuclei.

- ◆ We've now systematized all of the binding energies we've already measured and can predict the binding energies of more asymmetric nuclei. But the asymmetry and pairing terms are made up and do not come from a liquid-drop model. Instead, those terms come from quantum mechanics. We'll add the quantum mechanics a little at a time.

## The Fermi Gas Model

- ◆ Let's start with the Fermi gas model, which is the least amount of quantum mechanics we can add. We're going to confine the nucleons to the nucleus but ignore all of the details of the nucleon-nucleon interaction. We're going to include the Pauli exclusion principle, which tells us that we can only have one particle in each state at each time.

- ◆ So, 1 state is going to be a box of a certain size in space and in momentum, and the size of that in space times momentum is  $\hbar$ -bar

( $\hbar$ ):  $\Delta x \Delta p = \hbar$ . And  $\hbar$ -bar is **Planck's constant** ( $h$ ) divided by  $2\pi$ , or  $10^{-34}$  joule-seconds, or 200 fermis times a million electron volts divided by the speed of light:  $200 \text{ fm MeV}/c$ . The momentum is the mass times the velocity (nonrelativistically):  $p = mv$ . We also have to include the relativistic contraction factor:  $p = m\gamma v$ . We count protons and neutrons separately because they're separate particles.

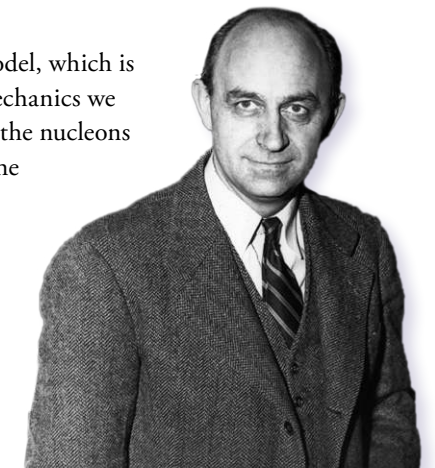

**ENRICO FERMI**

1901-1954

- ◆ So, in 1 dimension, we have protons in a box of size  $x$ , where  $x$  is the size of the nucleus. If we have 1 proton, it's going to have momentum  $\hbar$ -bar divided by the size:  $p = \hbar/x$ . If we have  $Z$  protons, the momentum will be the number of protons times  $\hbar$ -bar divided by the size:  $p_{\text{Fermi}} = Z\hbar/x$ . If we have  $N$  neutrons, the momentum will be the number of neutrons times  $\hbar$ -bar divided by the size:  $p_{\text{Fermi}} = N\hbar/x$ . It's actually half that, because we can put 2 protons in each box: spin up and spin down.
- ◆ The kinetic energy of the proton or neutron is  $\frac{1}{2}$  the mass times velocity squared, or momentum squared divided by twice the mass:  $\frac{1}{2}mv^2 = p^2/2m$ .
- ◆ This explains the preference for equal numbers of protons and neutrons. If we have the same number of protons and neutrons, they have the same Fermi momentum. But if we have 1 more proton and 1 fewer neutron, then the neutron momentum is a little less and the proton momentum is a little more, but the energy is the square of the momentum, so the total energy increases.
- ◆ How do we generalize this to 3 dimensions? Reality is not 1-dimensional. In 3 dimensions, we will fill each dimension separately. So, the box is now going to have a size of  $x$  times  $y$  times  $z$ :  $xyz$ . We will assume that we have the same Fermi momentum ( $p_{\text{Fermi}}$ ) in each direction.
- ◆ The number of protons we stack in the  $x$  direction is the Fermi momentum times the box size divided by  $\hbar$ -bar:  $N_x = p_{\text{Fermi}}x/\hbar$ . We do the same in the  $y$  direction and in the  $z$  direction. So, the total number is 2 (for spin) times the number in  $x$ , times the number in  $y$ , times the number in  $z$ :  $N = 2N_xN_yN_z$ . This means that the total number of protons will be 2 times the volume in momentum-space times the volume in space-space divided by the modified Planck's constant ( $\hbar$ -bar) cubed: 2 times (momentum volume) times (volume)/ $\hbar^3$ .

- ◆ Actually, we're going to use spheres and not cubes, so the Fermi momentum in a nucleus is going to go as the density (number of nucleons per volume) raised to the  $1/3$  power:  $p_{\text{Fermi}} \sim \text{density}^{1/3}$ . The Fermi momentum for nuclear density is  $270 \text{ MeV}/c$ , which gives us a kinetic energy for the nucleon at that Fermi momentum of 37 million electron volts. Because the binding energy is about 8 million electron volts, the potential energy of attraction is about  $-45$  million electron volts (it's negative because of the attraction; you have to put in energy to pull them apart).
- ◆ By using the quantum mechanics in the Fermi gas model, we have explained the asymmetry term in the liquid-drop model.

## Supplements

### READINGS

Henley and Garcia, *Subatomic Physics*, chap. 16.

Lilley, *Nuclear Physics*, sections 2.1–2.2.

Mackintosh, *Nucleus*, chap. 6.

### QUESTIONS

- 1 Why doesn't uranium-238 decay by beta-plus or beta-minus decay?
- 2 Which should take more energy: to knock a proton out of the center of a nucleus or to knock a proton out from the surface of a nucleus?

238Pu	239Pu	240Pu	241Pu	242Pu
237Np	238Np	239Np	240Np	241Np
236U	237U	238U	239U	240U
235Pa	236Pa	237Pa	238Pa	239Pa
234Th	235Th	236Th	237Th	238Th

## ANSWERS

- 1 Even though uranium-238 is unstable, it has a half-life of almost 5 billion years and lies in the valley of stability. It is an even-even nucleus. If it decayed by beta decay, either beta-plus or beta-minus, it would become odd-odd, because 1 of the protons would be become a neutron (or vice versa). Even-even nuclei are more stable than odd-odd nuclei because of the pairing term.
- 2 Protons in the center of the nucleus are more bound, because there are more nucleons around them that attract them. Protons on the surface of a nucleus have fewer neighboring nucleons to attract them and are therefore less tightly bound. Therefore, it will take less energy to knock out a proton from the surface of a nucleus.



# 07

## THE QUANTUM NUCLEUS AND MAGIC NUMBERS

**A**lthough nuclei can ring like a bell or spin like a top, the quantum structure of the nucleus is remarkably similar to the quantum structure of the atom, with single nucleons instead of electrons in *s*-shell, *p*-shell, *d*-shell, etc., orbitals. The atomic **shell model** works because it has the nucleus to provide a central force, the electromagnetic force is weak, and the electrons are point particles. In nuclei, on the other hand, the only central attraction is provided by the other protons and neutrons, the force is very strong, and the nucleons have substructure—they are made of quarks—that can be distorted by these forces. It's amazing that the shell model works for nuclei at all. ♦

## The Atomic Shell Model

- ◆ The liquid-drop model describes nuclear binding energies and the valley of stability. The Fermi gas model adds some quantum mechanics to explain why nuclei with similar numbers of protons and neutrons are more bound. These models do not explain everything we know about the nucleus.
- ◆ In chemistry, there is an atomic shell model. There are peaks in the energy it takes to remove an electron at the magic numbers—2, 10, 18, 36, and 54—corresponding to the noble gases [PAGE 270]: helium, neon, argon, krypton, etc. These peaks form a quantum pattern that is evidence for the atomic shell model, with electrons orbiting the nucleus in *s*-shells, *p*-shells, *d*-shells, etc.
- ◆ Similarly, there is a nuclear shell model, with its own set of magic numbers: 2, 8, 20, 28, 50, and 82.
- ◆ If we put the energy needed to remove 2 protons on a plot of the number of protons on the vertical axis versus the total number of nucleons on the horizontal axis—the chart of nuclides—then we see slightly darker horizontal bands for the proton magic numbers of 8, 20, 28, 50, and 82. If instead we put the energy needed to remove 2 neutrons on the same plot, then we see slightly darker diagonal bands for the neutron magic numbers of 28, 50, 82, and 126. This quantum pattern is evidence for the nuclear shell model.
- ◆ Nuclei with magic numbers of neutrons or protons—or both—are particularly stable and abundant. For example, tin (element 50, with 50 protons) has more stable isotopes than any other element. Other elements with magic numbers include helium-4, oxygen-16, calcium-40, and lead-208.

- ◆ To explain these magic numbers, we have to go beyond the Fermi gas model, which includes some quantum mechanics, such as the Pauli exclusion principle, but doesn't have any details of the nucleon-nucleon interaction. We need to include some details of the nucleon-nucleon interaction to explain these magic shell numbers.
- ◆ Let's start by looking at the atomic shell model, in which the electrons orbit around the nucleus in the mean field, the average force due to the nucleus plus all the other electrons. The positively charged nucleus provides a central potential, or force, diluted by the average of all the other electrons. Electrons are point particles; they have no structure and can't be distorted. And the electromagnetic interaction is weak.
- ◆ A potential is another way to describe a force. By "potential," we mean a potential energy curve. The force is due to changes in the potential energy with location. A hill is a gravitational potential energy curve. The force is downhill and depends on steepness. We use whichever description—either potential energy or force—makes it easier to solve a particular problem.
- ◆ The innermost electron "sees" all the charge in the nucleus ( $Z$  protons). The innermost electron orbits much closer to the nucleus and is much more tightly bound. In a neutral atom, the outermost electron "sees" a net charge of just  $+1$  (the effect of all of the protons plus the rest of the electrons). The rest of the electrons "screen," or neutralize, the rest of the nuclear charge.

## The Nuclear Shell Model

- ◆ How can we make a shell model work for nuclei? The protons and neutrons orbit around the other nucleons in the mean field due to the other nuclides, but there is no center. Furthermore, protons and neutrons are composite particles (they are made of quarks) and therefore

can be modified by the force; they interact by the complicated strong nuclear force and are pushed apart by the electromagnetic force. Despite all of these complications, the shell model works anyway—mostly.

- ◆ Let's use a simple example to show how we calculate the proton and neutron states. We assume that the average potential looks like the nucleons are attached to the center of the nucleus by a simple spring: The more you stretch the spring, the stronger the force. The force increases linearly with distance:  $F = -kx$ . This gives us a potential that increases as the distance squared, so the potential energy is the square of the distance from the center:  $\frac{1}{2}kx^2$ .
- ◆ This is very artificial, because if the potential looks like this, then the nucleons can never escape the nucleus. But the advantage is that it's easy to calculate, at least for physicists.
- ◆ When we make wave functions—that's the quantum mechanical description of the particles—in this simple spring model, we get 2 important quantum numbers that describe the distribution of a given proton or neutron.
- ◆ The first quantum number is the orbital angular momentum ( $L$ ), which tells us what shell the particle is in:  $s$ -shell,  $p$ -shell,  $d$ -shell, etc. In other words,  $L$  tells us how rapidly the particle orbits the nucleus: The bigger the orbital angular momentum, the more rapidly the proton orbits the nucleus. For a given value of  $L$ , there are  $2L + 1$  substates.
  - If  $L = 0$ , which is the  $s$ -shell, there is 1 substate. The  $s$ -shell is spherically symmetric, so it looks like a sphere.
  - If  $L = 1$ , which is the  $p$ -shell, there are 3 substates. The  $p$ -shell has 2 lobes.
  - If  $L = 2$ , which is the  $d$ -shell, there are 5 substates. The  $d$ -shell has 4 lobes.

- It keeps getting more complicated from here.

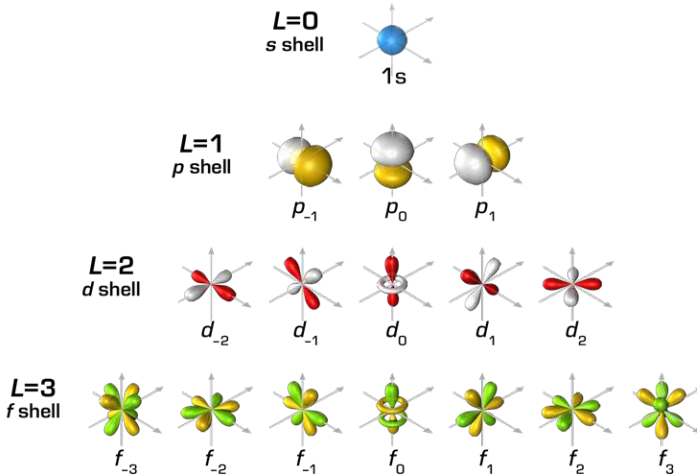

- ♦ Orbital angular momentum is similar to spin, which can be up or down. If  $L = 1$ , orbital angular momentum can be up, sort of horizontal, or down.
- ♦ The second quantum number is  $n$ , which is the principle quantum number. It can be 1, 2, 3, etc., and tells us how many wiggles there are in the wave function as it moves away from the center.
  - If  $n = 1$ , there are no wiggles, and it's the lowest energy.
  - If  $n = 2$ , there is 1 wiggle and a bit more energy.
  - If  $n = 3$ , there are 2 wiggles and even more energy.
  - This trend continues.

- ◆ These are very similar to the electron orbitals. When we put electrons in a nucleus, we start with the  $1s$  shell, followed by  $2s$  and  $2p$ ; then  $3s$  and  $3p$ ; then  $4s$ ,  $3d$ , and  $4p$ .
- ◆ The nuclear orbitals have the same names and shapes, but they're in a different order. The nuclear order is  $1s$ ,  $1p$ ,  $1d$ ,  $2s$ ,  $1f$ ,  $2p$ , etc. And the orbitals go beyond  $s$ ,  $p$ ,  $d$ ,  $f$  to  $g$ ,  $h$ ,  $i$ ,  $k$  ( $j$  is skipped because it can look too similar to  $i$  and cause confusion).
- ◆ The magic numbers are also not the same. The magic numbers for nuclei are 2, 8, 20, 28, 50, 82, etc., for protons, corresponding to helium, oxygen, calcium, nickel, tin, and lead. Neutron numbers—2, 8, 20, etc.—correspond to different isotopes.
- ◆ The chart of nuclides is frequently marked by horizontal and vertical lines showing the location of the magic numbers. But the magic numbers become less important as we go farther from the valley of stability.
- ◆ What do these quantum numbers do? We can combine the principle quantum number and the orbital quantum number to tell us where the major shells are. The energy ( $\lambda$ , or  $\Lambda$ ) defines major shells and is equal to  $2n + L - 2$ . The number of states in the shell is  $(\Lambda + 1)(\Lambda + 2)$ .
  - Let's start with  $\lambda = 0$ . The only way we can make  $\lambda = 0$  is if we have a principle quantum number of 1 and an orbital quantum number of 0—that's the  $1s$ -shell. There are 2 neutrons and 2 protons, which is helium-4.
  - To make  $\lambda = 1$ , we have principle quantum number 1 and orbital quantum number 1, which is the  $1p$ -shell. There are 6 neutrons and 6 protons in addition to the  $s$ -shell, which is oxygen-16.

The labels  $s$ ,  $p$ ,  $d$ , and  $f$  came from people looking through spectrographs at lines. There were “sharp” lines for  $s$ , “principal” lines for  $p$ , “diffuse” lines for  $d$ , and “fine” lines for  $f$ .

- If we have  $\lambda = 2$ , there are 2 ways to make it: with  $n = 2$  and  $L = 0$  (the  $2s$ -shell) or with  $n = 1$  and  $L = 2$  (the  $1d$ -shell). There are 12 neutrons and 12 protons, which is calcium-40.
- $\lambda = 3$  gives us a  $2p$ -shell or a  $1f$ -shell, with 20 neutrons and 20 protons. That gives us magic numbers of 40, but we don't have magic numbers there, so it doesn't work.
- The model works for the first 3 orbitals— $1s$ ,  $1p$ ,  $2s/1d$ —all the way up to calcium, but then it breaks down. We're going to need a more realistic—more complicated—interaction to describe the higher shells.
- ♦ Angular momentum interacts with itself. There are 2 types of angular momentum: spin and orbital angular momentum. The spin of the protons and neutrons is  $\frac{1}{2}$ ; the orbital angular momentum depends on the shell— $s$ -shell,  $p$ -shell,  $d$ -shell,  $f$ -shell, etc.—and corresponds to 0, 1, 2, 3, etc. The spin-orbit force, then, depends on the relative direction of the spin and the orbital parts.

<b>ORBITAL SHELL</b>	<i>s</i>	<i>p</i>	<i>d</i>	<i>f</i>	<i>g</i>	<i>h</i>	<i>i</i>	<i>k</i>
<b>ANGULAR MOMENTUM</b>	0	1	2	3	4	5	6	7

- ♦ The  $1p$  shell can have total angular momentum, which is equal to the orbital plus or minus (because direction matters) the spin:  $1 \pm \frac{1}{2}$ , which is either  $1 + \frac{1}{2}$ , which gives us  $\frac{3}{2}$ , or  $1 - \frac{1}{2}$ , which gives us  $\frac{1}{2}$ . So, we're changing the direction between the orbital angular momentum:  $\frac{3}{2}$  where the spins and the orbital angular momentum are aligned and  $\frac{1}{2}$  where they point in the opposite direction. Those 2 states previously had the same energy.

- ◆ The  $p^{3/2}$  state moves to a lower energy while the  $p^{1/2}$  state moves to a higher energy, and the energy of the shell splits. The bigger the angular momentum, the more splitting there is. So, the  $s$ -shell is unsplit, the  $p$ -shell is split a little, the  $d$ -shell is split more, and the  $f$ -shell is split so much that there is a shell energy gap between those 2 states. This gives us the correct magic numbers at the energy gaps in the shell structure.

---

The order of the proton orbitals in nuclei are very different from the order of the electron orbitals in atoms [PAGE 272].

---

- ◆ Why was adding this extra term—the spin orbit term—so important? It describes how the binding energies change at specific magic numbers, just like the binding energies change in atoms in noble gasses. It tells us how the energies of the shells split into subshells. It predicts the ground-state spins of nuclei 1 nucleon away from a closed shell as well as the excited states of these nuclei. Now we can describe nuclei in terms of their constituent protons and neutrons.
- ◆ How does this shell model relate to nuclear abundances? It turns out that even-even nuclei are more tightly bound and therefore are more common than nuclei with an odd number of protons, and nuclei with magic numbers are more abundant than their nearest neighbors. We can also use the shell model to accurately calculate nuclear densities.
- ◆ What are the limits of the shell model? It was created to describe stable nuclei, so interactions among many nucleons are relatively more important for weakly bound or unbound nuclei. And the magic numbers vanish for very unstable nuclei, with too many protons or too many neutrons. It's unclear what will happen in super-heavy nuclei, where there's a delicate balance between the short-range attraction and the long-range electrical repulsion.

## Quantum Vibrations and Rotations

- ◆ An entire nucleus can vibrate like a bell, where the whole nucleus is involved, and it's not just single nucleon excited states.
- ◆ In giant dipole resonance, the protons oscillate opposite to the neutrons. This is common in all medium to heavy nuclei. And as the nucleus gets bigger, the energy of this state decreases. It's about a 14-million-electron volt excited state in aluminum and about half of that in lead.
- ◆ There are also quadrupole resonances, where the nuclei oscillate between being slightly cigar-shaped (prolate) and slightly Frisbee-shaped (oblate).
- ◆ Then there are monopole resonances, where the whole nucleus expands and contracts.
- ◆ What does it mean when we find a bunch of nuclear excited states with evenly spaced levels? In the spring model, the excited states of particles on springs are evenly spaced. So, if we see a bunch of levels that are evenly spaced, then we're looking at vibrations that we can describe as 2 masses connected by a spring. So, a set of evenly spaced levels tells us that the nucleus is vibrating.
- ◆ We can explain other, uneven-level spacing with more quantum numbers. Those uneven levels can tell us that the nucleus is rotating. The energy for classical rotation is  $\frac{1}{2}\tau\omega^2$ , where  $\tau$  is the rotational inertia of the thing that's rotating (mass times distance from the axis of rotation squared) and  $\omega$  is the rotational speed (measured in rotations per second). The angular momentum, which is the rotational inertia times the rotational speed ( $L = \tau\omega$ ), is conserved.

- ◆ Quantum rotations have quantized energy and angular momentum. We look for energy levels that—instead of being evenly spaced, like with vibrations (1, 2, 3, 4, etc.)—are the square of the angular momentum ( $L^2$ ): 1,  $2^2 = 4$ ,  $3^2 = 9$ , etc.
- ◆ But quantum mechanical spheres can't rotate because there is no difference between different orientations. That means that magic nuclei, such as oxygen-16 and lead-208, can't rotate.
- ◆ Cigars and pancakes (prolate and oblate spheroids) can rotate and typically have a set of energy levels that is spaced as the angular momentum squared ( $L^2$ )—these rotational states. So, if we see a set of rotational states, that tells us that the nucleus is not spherical.
- ◆ How do we measure these rotational bands? Practically, we measure the cascade of gamma rays as each rotational state decays down to the next one, and the energies correspond to the energy differences between the states. This lets us measure the rotational inertia of the nucleus and tells us how deformed it is. And we discover that the energy levels don't exactly match this pattern because the faster the nucleus rotates, the more deformed it gets and the more rotational inertia it has.

## Supplements

### READINGS

Henley and Garcia, *Subatomic Physics*, chaps. 17–18.

Lilley, *Nuclear Physics*, sections 2.3–2.5.

National Research Council, *Nuclear Physics*, p. 30–56.

## QUESTIONS

- 1 How are nuclear and atomic structure similar? How do the proton and neutron orbitals in a nucleus compare with the electron orbitals in an atom?
- 2 Elements with filled *atomic* shells (i.e., with magic numbers of electrons), such as helium, neon, and argon, react very differently than other elements. Why don't elements with filled *nuclear* shells (i.e., with magic numbers of protons and neutrons), such as oxygen-16, calcium-40, and lead-208, react very differently than other elements?

## ANSWERS

- 1 The protons and neutrons in the nucleus occupy orbitals that are very similar to the electron orbitals around an atom, although 10,000 times smaller. The big differences are that the protons and neutrons fill their orbitals in a different order than the electron orbitals, and the energy gaps (the magic numbers) are in very different locations.
- 2 The chemical reactivity of an element is determined by its electronic structure, because chemical reactions are driven by sharing electrons. The nuclear structure of an isotope has almost no effect on its chemical reactivity. Isotopes with filled nuclear shells are more stable and are thus more likely to be produced in nuclear reactions.





# 08

## PARTICLE ACCELERATORS: SCHOOLS OF SCATTERING

In this lecture, you will learn about the techniques that are used to develop and test models of the nucleus. These new techniques will allow us to go beyond the bulk properties of nuclei—mass, spin, binding energy—and look more closely at how the individual nucleons behave. This lecture will focus on how and why we accelerate the subatomic particles that we then scatter from nuclei. Together, beams of heavy ions, radioactive ions, and electrons show us where nuclei come from, the most extreme examples of what a nucleus can be, and the internal structure of the nucleus. ♦

## Scattering Particles and Studying Reactions

- ◆ Before 1911, the atom was seen as a plum pudding—a uniform blob with the electrons interspersed. In that model, massive alpha particles passing through matter would only be slightly deflected.

- ◆ In 1909, Hans Geiger and Ernest Marsden, who were working in Ernest Rutherford's lab, aimed alpha particles from radium decay at very thin gold or platinum foils. This was one of the first scattering experiments; they didn't accelerate the alpha particles. To detect the particles, they counted light flashes on small zinc sulfite screens from alpha particles hitting the screen. The alpha particles scattered in all directions. Most of them went straight, some of them bounced off at small angles, and 1 out of 8000 bounced backward.

- ◆ Rutherford interpreted this backscatter as due to a very large force on the alpha particles. The force was due to the electrical repulsion from the nucleus. The electrical repulsion gets much bigger as the distance gets smaller and smaller. That meant that there needed to be a large amount of charge in a very small region and a large amount of mass in that region so that it didn't get pushed out of the way. This scattering experiment didn't determine whether the central charge of the nucleus was negative or positive. That came later.

**PLUM PUDDING  
MODEL OF THE ATOM**

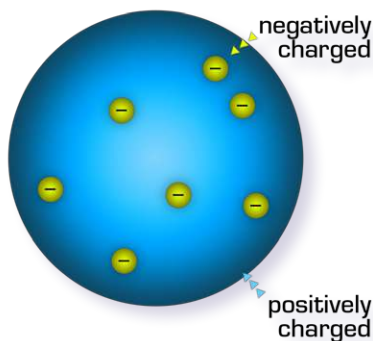

- ◆ This experiment showed the existence of tiny, massive atomic nuclei. It was the first experiment to scatter subatomic particles from the nucleus. All nuclear physicists are doing today are fancier and fancier versions of Rutherford's experiment.
- ◆ Why do we need higher energies—and accelerators to provide them? The smaller the wavelength of our probe, the better we can see things. You can't see features smaller than the wavelength of what you're looking with. With photons, the wavelength is Planck's constant times the speed of light divided by the energy:  $\lambda = hc/E$ . But photons also have momentum, and that is the energy divided by the speed of light:  $p = E/c$ . That means that the wavelength of a photon is Planck's constant divided by the momentum:  $\lambda = h/p$ .
- ◆ This is also true for particles. Just like photons travel as waves and interact as particles, particles travel as waves and interact as particles in quantum mechanics. Their wavelength is also equal to Planck's constant divided by their momentum:  $\lambda = h/p$ . Planck's constant ( $h$ ) multiplied by the speed of light ( $c$ ) is 1200 MeV fermis. That means that if we want a wavelength of 1 fermi, we need a momentum of about 1000 MeV/c. Geiger and Marsden's alpha particles had a momentum of only about 200 MeV/c, so they could see that the nuclei were in a small region, but they couldn't see any details about the nucleus.
- ◆ We also want higher energies to study different (inelastic) reactions: excite the nucleus to different states, knock particles out of the nucleus, and make new nuclei. There are 3 main types of large accelerators. There are electron accelerators, such as at the Thomas Jefferson National Accelerator Facility (Jefferson Lab). There are also ones that accelerate heavy ions. And there are 2 main types of those. At high energy, accelerators such as the Relativistic Heavy Ion Collider in New York and the Large Hadron Collider in Switzerland and France study the quark-gluon plasma.

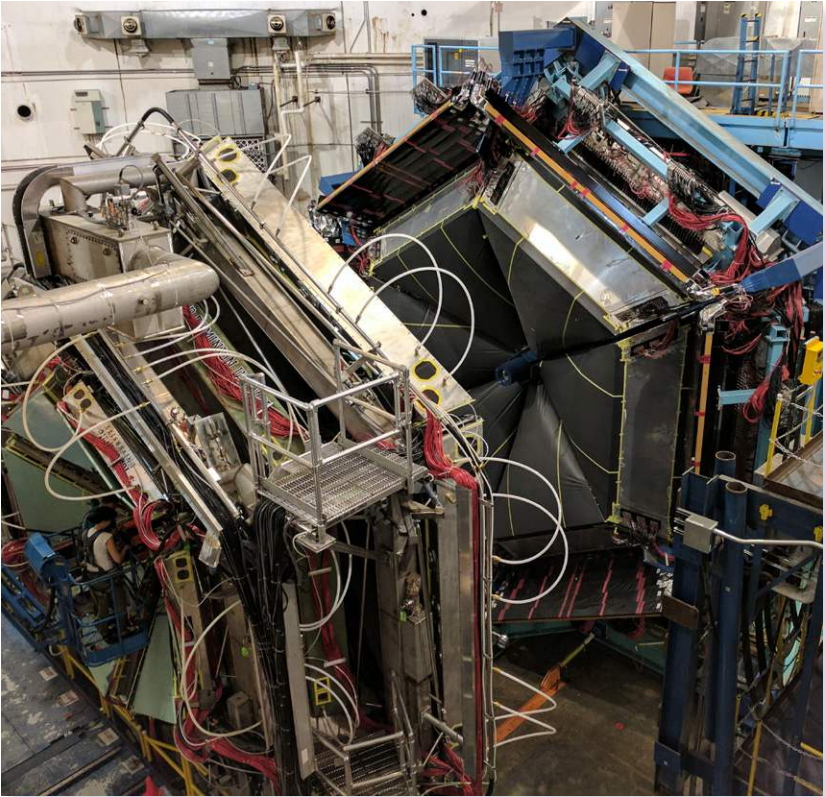

Thomas Jefferson National Accelerator Facility  
(Jefferson Lab)

- ◆ At lower energies, accelerators such as the Facility for Rare Isotope Beams or [Van de Graaff generators](#) accelerate heavy ions to make unusual nuclei and to make nuclei in unusual excited states. We need this information to understand stellar nucleosynthesis—how stars make nuclei.

- ◆ Why do we use electron scattering? Electrons are point particles; they don't have a complicated structure. Plus, they interact via the electric and magnetic forces, which are well understood.

The famous Van de Graaff generator is a powerful electrostatic accelerator of protons or ions. And while it's used in some research accelerators, you can also see it in science museums, usually for hair-raising demonstrations.



## Accelerating and Colliding Particles

- ◆ How do electrons interact with nuclei? There are several possibilities:
  - 1 The electron can elastically bounce off the nucleus, leaving the nucleus unchanged. In this case, we measure the charge distribution of the nucleus.
  - 2 The electron can excite the nucleus to a specific shell-model or rotational state, and we can measure the energy, spin, etc., of that state.
  - 3 The electron can excite the nucleus to a giant resonance, where the protons and neutrons oscillate back and forth.
  - 4 The electron can interact with single nucleons or quarks, giving us information about the nucleon or quark distribution in the nucleus.
- ◆ We also hit the nucleus with other particles, such as protons or other nuclei. We do that to try to understand the nucleon-nucleon force and to make new nuclei. Also, the proton and other ions interact strongly, so we can learn about the strong force.
- ◆ We don't use neutrons that often because they don't live long enough—only about 15 minutes. They're very difficult to accelerate and steer, because they have no charge. So, we predominantly use protons and ions.
- ◆ How do we accelerate protons and ions?

The first technique is called the **cyclotron**, which is a large **magnet** with a circular pole face. There are 2 parts of it—2 halves that look like Ds—and an alternating voltage is applied to the gap between the 2 Ds.

One of the biggest cyclotrons is the 88-Inch Cyclotron at Berkeley.

# CYCLOTRON

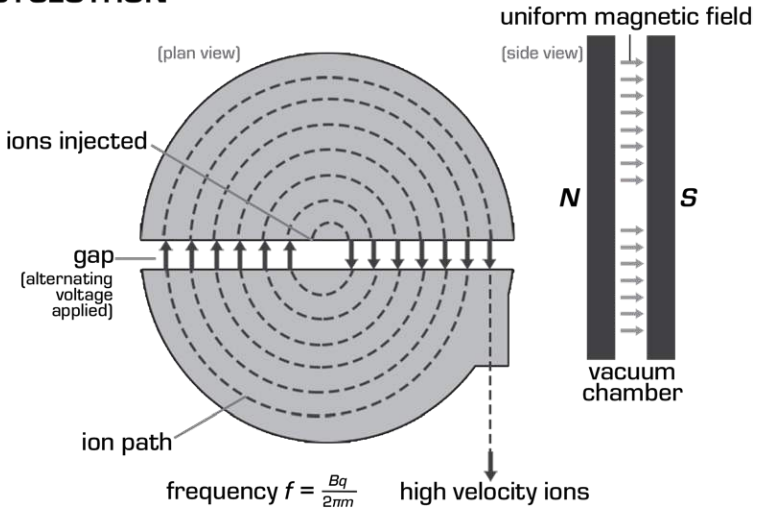

- ◆ We inject an ion near the gap, and the voltage accelerates the ion toward the other D. The magnetic field then bends the ion trajectory around in a circle, and the radius of that circle is the mass times the velocity divided by the charge and the magnetic field:  $R = mv/qB$ . As the velocity increases, the radius gets bigger, but the time it takes to go around the half circle doesn't change. By the time the particle comes back to the gap, the voltage has reversed, and the voltage now accelerates the particle the other way. Then, this process is repeated. The bigger the cyclotron, the more energy we get. Today, cyclotrons are mostly used to accelerate protons for proton cancer therapy.
- ◆ The problem with cyclotrons is they have a maximum useful energy. There are 2 causes of this. First, the magnets just get too big. Second, the cyclotron relies on the fact that the proton takes the same amount of time for each of its semicircles—whether it's a small one at low speed

or a big one at high speed—and that timing gets messed up when the proton starts traveling too close to the speed of light and special relativity complicates things.

- ◆ While a cyclotron has a fixed magnetic field and lets the radius motion of the proton get bigger and bigger, a **synchrotron** has a fixed radius and increases in magnetic field. A synchrotron is a ring of bending magnets—plus focusing magnets and accelerating cavities and the same radio frequency cavities as electron accelerators. As the particle accelerates and gets closer to the speed of light, we increase the magnetic field to match.
- ◆ At Fermilab, they extract the high-energy beam periodically. At the European Organization for Nuclear Research (CERN), they have 2 counter-rotating beams where they collide particles. They strip electrons from protons or other nuclei, accelerate them first in a **linear accelerator** and then in 2 synchrotrons to boost up the energy. Then, they inject them into the ring of the Large Hadron Collider and accelerate them up to 12 trillion electron volts. A huge radius is needed to achieve these huge energies, because it's limited by the maximum magnetic field that we can make with electromagnets. That's why CERN's Large Hadron Collider stretches for tens of miles.



- ◆ With these accelerated particles, we measure how protons and neutrons interact by elastically scattering protons from other protons and from neutrons. We also use protons to study the nucleus. We aim protons at a target containing an interesting isotope and count the number of particles emitted at a certain angle and energy. We measure **cross sections**, which are the number of particles that are emitted at a certain angle and energy divided by the number of beam particles hitting the target and the areal density (number of nuclei per square centimeter) of the target. We measure cross sections in units called barns which are  $10^{-24}$  cm<sup>2</sup>, or  $10^{-28}$  m<sup>2</sup>. A barn is a measure for the effective area of the target for the reaction we're interested in.
- ◆ We use barns to measure the probability of different interactions. For example, we might aim a proton beam at a calcium-48 target and measure the protons that come out with **elastic scattering**, leaving the calcium-48 nucleus unchanged. Or we might measure the protons that come out, leaving the calcium excited to a specific state. Or we might measure the neutrons that come out, leaving a different nucleus behind.
- ◆ What about bigger collisions? When a nucleus hits another nucleus, there is a large electric repulsion energy, which is the charge of the first nucleus times the charge of the second nucleus divided by the distance between them. This is typically about 10 million electron volts.
- ◆ At energies slightly higher than this barrier, the cross sections are large—about 0.1 barn. There are big changes to those nuclei. These are big collisions. We can transfer up to 20 nucleons from one nucleus to the other, or maybe they could even stick together. We could transfer huge amounts—50 units—of angular momentum. When we're doing this, we're studying nuclei in extreme conditions. We're looking for new isotopes, ultraheavy elements, and ultrahigh spin. We're looking at nuclei far from the valley of stability.

## Making New Elements and Isotopes

- ◆ How do we make new elements? For example, we can accelerate calcium-48 to a tenth of the speed of light, but because it has such a heavy mass, it's actually not that much energy—only about 10 million electron volts for each nucleon. Then, we can collide it with one of the heaviest nuclei that's stable enough to make a target of: americium-241. We often vary the speed of the projectile and target. Then, because americium has 95 protons and calcium has 20 protons, we look for element-115 in a mass spectrometer—with a much lower velocity, about 0.02 times the speed of light—and measure its alpha decay with a time of, in this case, about 0.2 seconds. Element-115, moscovium, was discovered in Dubna and confirmed in a lab called GSI in 2013.
- ◆ How do we make and then study new isotopes? We smash nuclei into other nuclei, use a mass spectrometer to separate out the desired new isotope to study, reaccelerate these nuclei, smash them into other targets, and see what comes out.

## Supplements

### READINGS

Borel, “Making New Elements.”

FRIB Users Organization, *FRIB*.

Henley and Garcia, *Subatomic Physics*, chap. 2.

Lilley, *Nuclear Physics*, sections 6.8 and 4.6.

National Research Council, *Nuclear Physics*, p. 30–56 and 80–104.

## QUESTIONS

- 1 What would be the best particle and energy to collide with a proton to study the distribution of quarks inside the proton?
- 2 What would be the best particle and energy to collide with uranium to make an ultraheavy nucleus?

## ANSWERS

- 1 The best particle would be an electron, because it has no structure itself. The best energy would be as high as possible, to get the smallest-possible wavelength to resolve the smallest structures in the proton. The smaller the wavelength, the more detail we see in the proton.
- 2 The heaviest known nucleus as of 2017 was oganesson, with 118 protons. If we wanted to make element 119, then we would want to accelerate a nucleus with  $119 - 92 = 27$  protons, or cobalt. Because ultraheavy elements have a large neutron excess, we would want an isotope with a lot more neutrons than protons. However, the only stable isotope of cobalt is cobalt-59, with only 32 neutrons. If instead we use nickel, we can use nickel-64, with 28 protons and 36 neutrons. We want to use the lowest-possible energy that will allow the cobalt or nickel projectile nucleus to barely overcome the electrical repulsion and fuse with the uranium target nucleus.





09

## DETECTING SUBATOMIC PARTICLES

**P**article detectors see the subtle traces left behind as high-energy particles pass through them. In this lecture, you will learn how to measure individual attributes of single particles. ◆

## High-Energy Particles

- ◆ To detect high-energy particles, we use the tiny amount of energy they leave behind as they pass through matter. Charged particles interact with atomic electrons. They excite and ionize them. Then, we can either collect the ionized electrons as an electrical signal or detect the light emitted as the electrons recombine with their atoms or deexcite.
- ◆ What can we learn from the amount of energy left behind by these charged particles? The slower the particle moves, the more it interacts, and the more energy it leaves behind: energy  $\sim 1/v^2$ . Particles with more charge deposit more energy: energy  $\sim z^2$ .
- ◆ Surprisingly, the mass of the particle doesn't matter. Protons, deuterons, and even tritium nuclei deposit the same amount of energy as each other. It only depends on the velocity and the charge. It also depends on the material they're passing through. They'll deposit the most energy per gram of hydrogen, and then helium, and then everything else, because it depends on the number of electrons in that material.
- ◆ With neutral particles, we wait until they hit something and then detect the charged particles that are knocked out. High-energy photons—for example, gamma rays between 0.1 and 10 million electron volts—are about a million times more energetic than the photons from the Sun. These high-energy photons can be absorbed on an atom and knock an electron loose. This is called the photoelectric effect. Or they can bounce off an electron in the atom, and the electron will recoil.
- ◆ With the photoelectric effect, we get all of the energy of the gamma ray. When the electron recoils, we get just some of the energy of the gamma ray. Really-high-energy photons, above 10 million electron volts, will make an electromagnetic shower.

- ◆ Neutrons travel through material until they hit a nucleus and knock out one or more protons. The typical interaction distance is about 30 centimeters (about 1 foot) of plastic (or water or people), or about 4 centimeters (about 1.5 inches) of iron, or about 2.5 centimeters (about 1 inch) of lead. We then detect the energy left behind by the protons that were knocked out by the neutrons as they travel.

## Scintillator Detectors

- ◆ To detect such a tiny flash of light, we use **scintillator** detectors, which detect the light from the ionized or excited electrons that were knocked loose in the material when they recombine or deexcite. These are higher-tech versions of the zinc-sulfide screens used by Hans Geiger and Ernest Marsden.
- ◆ There are 2 main types of scintillator detectors: inorganic crystals or organic scintillators. Inorganic crystals, such as sodium iodide or germanium, have really good energy resolution for measuring the energies of gamma rays—high-energy photons. But they're much too slow for some purposes; they can take up to a millionth of a second to produce the light.



Scintillator at Jefferson Lab

- ◆ To have a much faster scintillator, we use organic scintillators that are common plastics that have been doped with a special material. When a high-energy charged particle passes through the plastic, it deposits some energy, which goes into jiggling the atomic electrons. When those atomic electrons recombine, they give off tiny flashes of light.
- ◆ The light is emitted in all directions. Light emitted within  $45^\circ$  travels toward the **photomultiplier tube** on the end. Light at larger angles escapes the scintillator. If the scintillator is longer than it is wide, the light totally internally reflects from the edges as it travels to the tube. Then, the light hits a photocathode on the tube and knocks electrons loose (about 1 electron per 4 photons).

## PHOTOMULTIPLIER TUBE

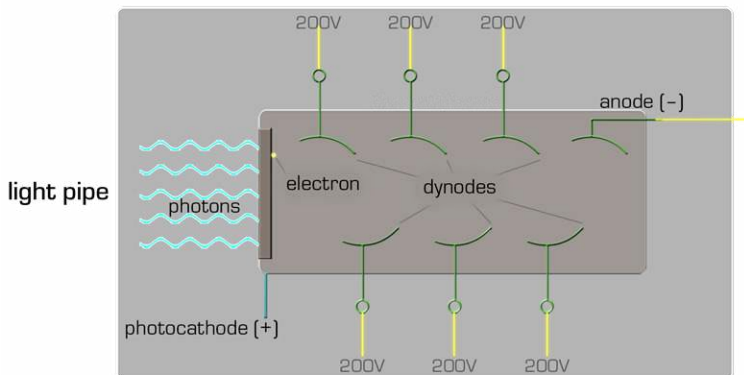

- ◆ The electrons are then amplified by the photomultiplier tube and emerge as an electronic signal. The electrons from the tube are then accelerated by the voltage difference from the tube to the first **dynode**, or the first part of the multiplying structure, where they knock more electrons loose. This process is repeated for 6 or 8 or 12 dynodes, causing an avalanche of electrons, which is finally accelerated to the anode, where the signal is read out.

## Geiger Counters and Wire Chambers

- ◆ A Geiger counter can be used to detect radiation—such as alpha, beta, and gamma radiation and cosmic rays—by chirping when radiation passes through the sensitive part of it. It consists of a gas-filled tube at ground and a thin wire that runs down the center of the tube and is at positive high voltage. A charged particle or a photon passes through the tube and knocks electrons loose from the atoms of gas. Those electrons drift toward the central wire, getting amplified as they go, resulting in a big electrical signal and a click of the wire.
- ◆ The great thing about Geiger counters is they let you count radiation and hear how much radiation there is. The problem is they can't count that quickly. It can't really count more than 1000 or a few thousand times per second. And in modern physics experiments, we need detectors that can count hundreds of thousands or even millions of times per second. And it only covers a very small area—just the area of the tube.

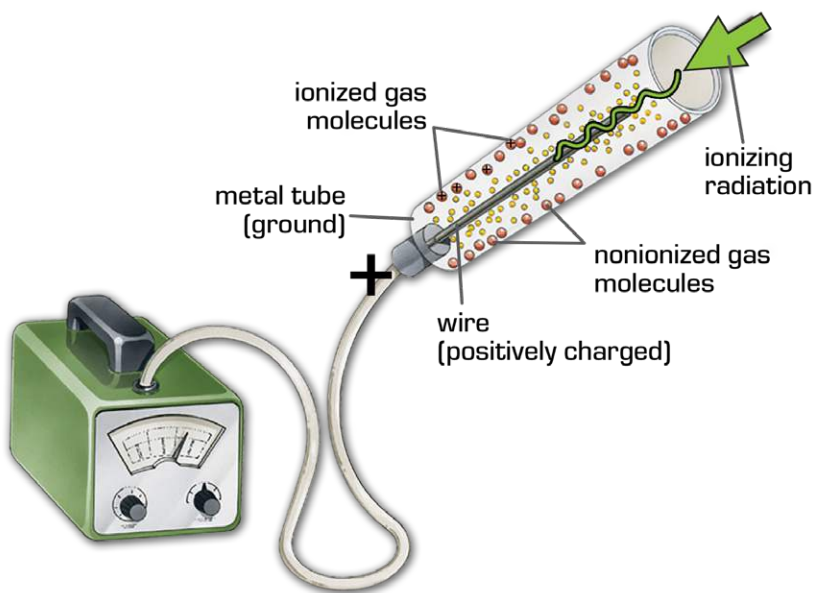

✦ **Wire chambers** are bigger, faster, better Geiger-type counters. Where a Geiger counter has 1 wire passing through a cylinder, a wire chamber contains several field wires at negative high voltage and 1 sense wire at positive high voltage. The field wires function like the cylinder. A charged particle passes through the gas and knocks electrons loose, and the electrons drift toward the sense wire. When they get close enough to it, the electric field is big enough in between collisions with the gas molecules, and the electron gains enough energy that it can knock another electron out of the gas molecule, resulting in an avalanche and a detectable signal.

### GEIGER CHAMBER CYLINDER

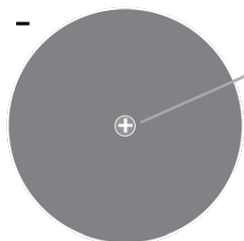

### WIRE CHAMBER HEXAGON

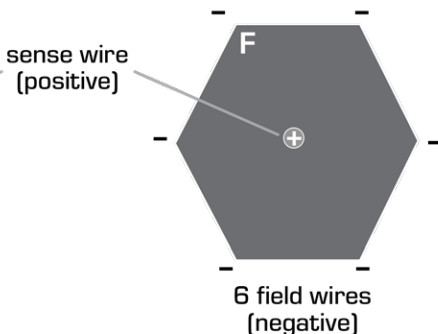

✦ There are 2 differences between Geiger counters and wire chambers. First, the amplification is not as big in a wire chamber, so we don't get a click or chirp; instead, we get a signal we have to read out by computer. But because we don't get that huge signal, we can have a lot more of them, so the process can go a lot faster. Second, instead of having a tube with a wire in it, wire chambers have several field wires surrounding a sense wire. A full-sized chamber might have a few thousand sense wires and a few thousand field wires around them, so we can cover huge areas.

- ◆ To get more information, we can place scintillators after wire chambers to measure the arrival time of charged particles. Scintillators can measure the arrival time of a charged particle very precisely—to better than a nanosecond. Specifically, a scintillator can measure how long it took for the signal to get from where the charged particle passed through the wire chamber to the sense wire.
- ◆ Electrons are drifting to the sense wire very slowly. The drift time is the difference between the arrival time of the charged particle and the sense wire signal time. This is proportional to the drift distance, which is how far away the charged particle passed from the sense wire. Drift distance can be measured to a fraction of a millimeter, so we can measure the track of the charged particle passing through the wire chamber very precisely. And we can do this over a huge area and thousands—or tens or hundreds of thousands—of times per second.

## Shower Counters

- ◆ To measure the energy of a particle, we use a shower counter. It measures the energy of electrons or photons. And just as we can convert mass to energy—an electron and an antielectron combine to produce energy—here we can reverse the process. A high-energy photon comes in, and if it passes through something heavy, such as lead, some of the time it's going to pair-produce. In other words, instead of an electron and an antielectron combining and annihilating to produce photons, the photon will pair-produce to make an electron and a positron (the antiparticle of the electron).
- ◆ The other thing that could happen is an electron or a positron passing through the lead will radiate a photon. If you start with a photon, after passing through a certain amount of lead, you end up with an electron and a positron. If you start with an electron, you end up with

an electron and a photon. If you start with a positron, you end up with a positron and a photon. We started with 1 particle; now we have 2. Eventually, this process results in a whole shower of particles.

- ◆ The electrons and positrons end up depositing all of their energy in the **scintillant**. By measuring this energy, we can reconstruct the initial energy of a photon or electron.

## Cherenkov Counters

- ◆ Nothing can go faster than the speed of light in vacuum. But the speed of light in material is slower than the speed of light in vacuum. The speed of light in water is 30% slower; the speed of light in air is 0.1% smaller. So, if a particle traveling through that material is going faster than the speed of light in the material, it gives off an electromagnetic boom, or a tiny flash of light.

If something, such as a supersonic airplane, is going faster than the speed of sound in air, it makes a sonic boom.

- ◆ The blue glow in nuclear waste pools comes from these flashes of light, called Cherenkov light or **Cherenkov radiation**, after Pavel Cherenkov. **Cherenkov counters** can measure the velocity of a particle. There is a threshold Cherenkov counter that detects that flash of light—that electromagnetic boom—if the particle traveling through the Cherenkov counter is faster than the speed of light in the material. There are also ring imaging Cherenkov counters that measure the size of the cone of light emitted by the particle. The faster the particle moves, the wider the cone is.

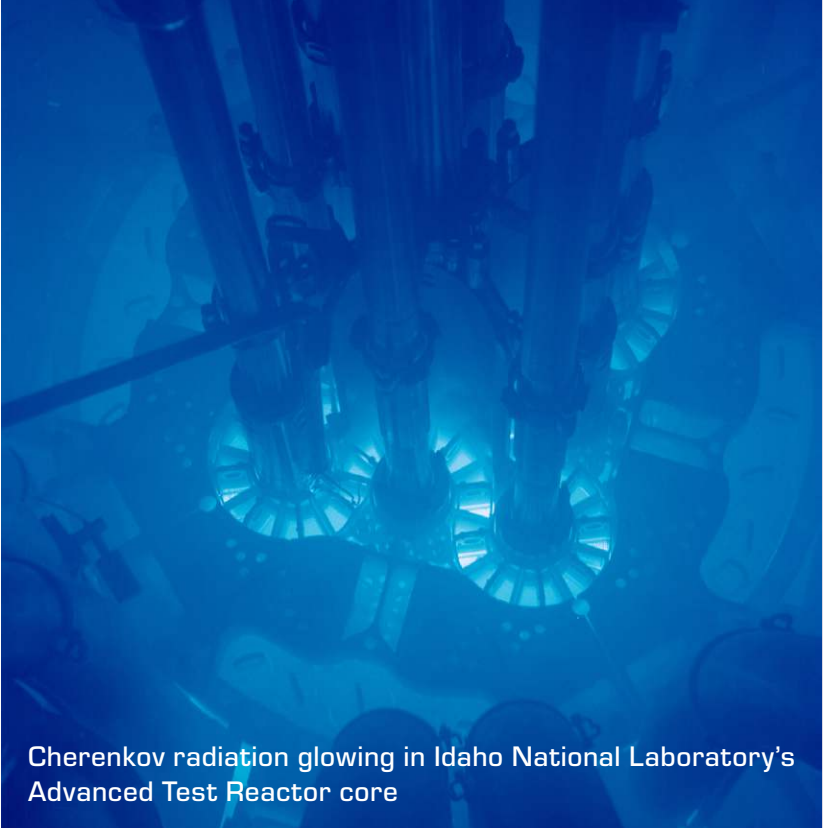

Cherenkov radiation glowing in Idaho National Laboratory's Advanced Test Reactor core

## Supplements

### READINGS

Henley and Garcia, *Subatomic Physics*, chap. 4.

Leo, *Techniques for Nuclear and Particle Physics Experiments*.

Lilley, *Nuclear Physics*, chap. 6.

## QUESTIONS

- 1 Why is it so much easier to detect high-energy charged particles than neutral particles, such as neutrons and photons (gamma rays)?
- 2 How could Geiger and Marsden detect alpha particles with their naked eyes?
- 3 Why do we use photomultiplier tubes to multiply and amplify the signals emitted by scintillators?

## ANSWERS

- 1 This is because charged particles interact with large numbers of the electrons in the material that they pass through. They ionize some atoms, knocking electrons loose, and they excite other atoms, exciting electrons to a higher energy state. We can either collect and amplify those knocked-out electrons to make a detectable electric signal, or we can collect the light emitted by the deexcitation of the excited electrons. Neutral particles do not interact with those atomic electrons. For neutral particles to be detected, they need to have a hard collision with an atom or an atomic electron and knock out a charged particle. We can then detect the charged particle that is knocked out by the photon or neutron.
- 2 The alpha particles hit a zinc-sulfide screen, which gives off light when hit. Alpha particles interact more strongly with material and deposit much more energy than electrons, so they produce much more light when they hit a zinc-sulfide screen. The human eye is also extremely sensitive and can detect very faint light flashes when completely adapted to the dark.
- 3 We use photomultiplier tubes for 2 reasons: to amplify very faint signals that could not have been seen with the naked eye and to convert the flash of light into an electrical signal that we can record in a computer.

# 10

## HOW TO EXPERIMENT WITH NUCLEAR COLLISIONS

**T**his lecture is about reconstructing nuclear collisions. To measure the momentum and the type—such as electron, proton, pion—of the knocked-out particles after the collision, large magnets are combined with particle detectors to make spectrometers. The particles are passed through large magnets, which bend the trajectories of the particles to determine their momentum. Then, the positions of the particles—and hence their momentum—are measured with detectors such as wire chambers. The type of each particle is measured using detectors such as scintillators, Cherenkov counters, and shower counters. ◆

## Spectrometers

- ◆ Spectrometers detect and measure properties of the particles that are knocked out in the collision between an electron and the nucleus, for example. A spectrometer needs to have 2 things: a **dipole magnet** to spread out the momentum of the particles and detectors to detect those particles. Lower-momentum particles traveling through the dipole magnet will be bent more; higher-momentum particles will be bent less. The detectors will be able to measure the positions of those particles to determine their momentum.

Spectrometers in experimental Hall C at Jefferson Lab measure what happens when electrons collide with nuclei.

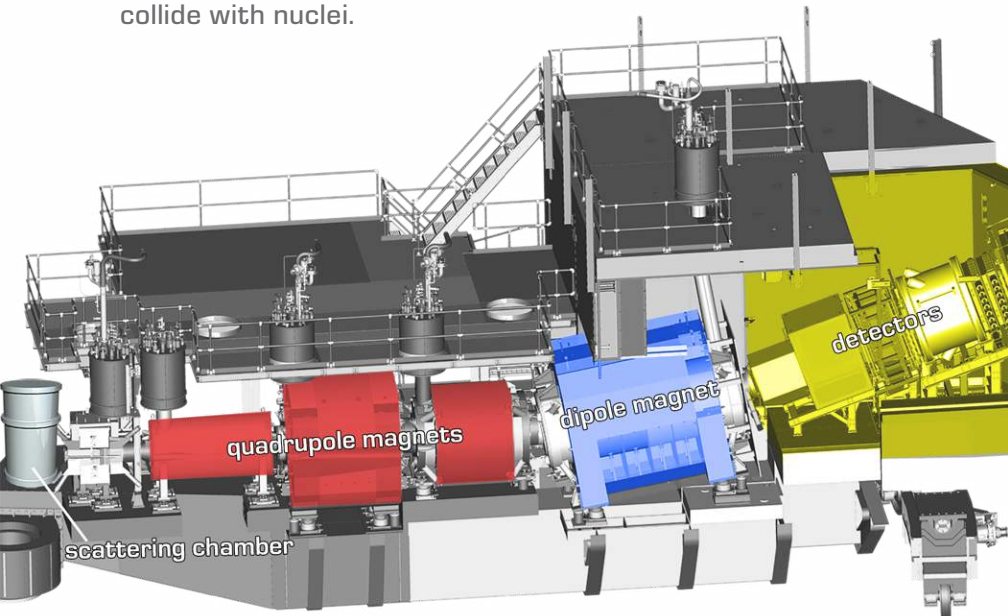

- ◆ **Drift chambers** are used to detect and measure particle positions. Each drift chamber consists of many very fine wires sandwiched between 2 very thin aluminized Mylar foils with gas in between and high voltage on the wires. When the particle that we want to detect passes through the gas, it knocks electrons loose. The high voltage causes those electrons to drift toward the wire and then to be amplified, so we measure an electrical signal. By determining which wire saw the signal and how long it took those electrons to drift from where they were knocked out of the gas to the wire, we can measure the position of the particle that passed through the drift chamber to a fraction of a millimeter. We can trace a particle's trajectory back through the magnetic field to know its momentum and angle as it left the target.
- ◆ Once we know the momentum of the particle, we need to figure out what type of particle it is (electron, pion, proton, etc.). We need other detectors to do this. The first one is a scintillator detector, which gives off a tiny flash of light when a high-energy charged particle passes through it. We detect that tiny flash of light and can measure its time to within a fraction of a billionth of a second. That helps tell us the speed of the particle.
  - ◆ After the particle passes through the scintillator, the next detector is a Cherenkov counter, which gives off a tiny flash of light when a particle traveling through it is traveling faster than the speed of light. The Cherenkov counter helps tell us whether the particle was an electron or something else.
  - ◆ The last detector is an **electromagnetic calorimeter** that also helps distinguish between electrons and other particles. An electron that enters the calorimeter will start an electromagnetic shower and will deposit a lot of its energy in the calorimeter. Other particles traveling through the calorimeter will deposit much less energy, and from the amount of energy deposited, that will also help tell us whether it's an electron or something else.

- ◆ Typically, we want to detect the electron that bounced off the nucleus and some other particle. To determine the identity of the other particle, we use the relative time that the particle arrived in 2 spectrometers. The 2 types of spectrometers that are used to look at the particles coming out of collisions are small-aperture spectrometers and large-acceptance spectrometers.
- ◆ The small-aperture spectrometer can typically detect 1 particle at a time, and the particle has to go in a particular angle and in a particular range of momentum. When we want to detect more particles or over a wider range of angles or of momentum, we use a large-acceptance spectrometer.
- ◆ A small-aperture spectrometer just needs a magnetic field in a limited region to analyze the particles that go into it. A large-acceptance spectrometer needs a magnetic field over a huge volume because it's detecting particles over a wide range of angles and of momentum. That means that the magnetic field is going to be weaker than the magnetic field in a small-aperture spectrometer, which also means that our ability to measure momentum won't be as good in a large-acceptance spectrometer. We also need bigger detectors with large-acceptance spectrometers because the detectors have to cover a much wider area.
- ◆ So, why would we use a large-acceptance spectrometer? We might be studying heavy ion collisions, where a lead nucleus hits a lead nucleus and dozens or hundreds or thousands of particles come out in all directions and we want to detect all of them. Or we might be at an electron scattering lab and an electron hits a nucleus and we want to detect more than 2 particles. Alternatively, we might want to do a number of experiments at the same time; a range of different scientists can take the same data with the same beam on the same target and analyze it for different reactions.

- ◆ With a small-aperture spectrometer, only the particles going out at a small angle in a narrow range of momentum make it from the target to the detectors. That means it can use a really intense beam and a really thick target and make lots of nuclear collisions and just pick out the ones that we are interested in, because only a tiny fraction of those particles make it up to the detectors. (The fact that a small-aperture spectrometer can use a very intense beam also means that it can measure small things very precisely, which is a great benefit.) With a large-acceptance spectrometer, we're looking at just about all of the particles knocked out in the collisions, so we have to turn the beam intensity way down to be able to handle everything.
- ◆ Jefferson Lab has 2 large-acceptance spectrometers: one in Experimental Hall D and one in Experimental Hall B known as the CLAS, or the CEBAF Large Acceptance Spectrometer.

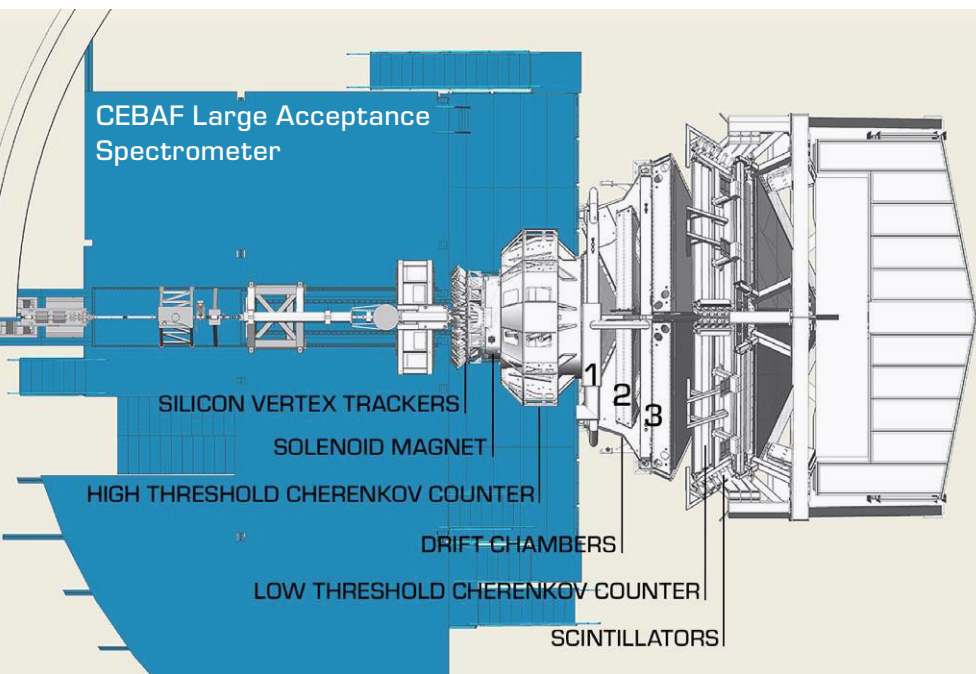

- ◆ With these spectrometers, the electron beam hits a target in the center of the **solenoid**, which provides a magnetic field. Every now and then, one of the electrons hits one of the nuclei in the target. It bounces off and knocks other particles out. Lower-momentum particles go in all directions. If they go in large angles—from  $45^\circ$  to  $135^\circ$ —we detect them in the detectors of the central detector and measure their position and time to get their momentum and what kind of particle they are.
- ◆ Higher-energy particles go forward. They go through 3 layers of drift chambers before, in the middle, and after the magnetic field from the **superconducting** torus magnet. Then, they pass through the Cherenkov counters, the scintillators, and the electromagnetic calorimeters.
- ◆ Using all of this information, we can measure the momentum of each particle in the event and we can measure what kind of particle it is—whether it is an electron, a pion, a kaon, or a proton. And we can use that information to completely reconstruct all of the particles emitted in an electron-nucleus collision.

## How Do We Do an Experiment?

- ◆ To do an experiment, we first have to come up with an idea. There has to be some question that we want to answer. For example, how does the motion of protons in the nucleus depend on the number of neutrons? To answer this question, we have to figure out numerous things, including what we can measure, what we already know, why this is important, how much beam time it takes to measure this, which experimental hall to use, what beam energy we want to use, and how much time it will take to do the measurement. Then, we write all of this up in an experimental proposal.

- ◆ Next, we defend the proposal to the Program Advisory Committee, which is a committee at Jefferson Lab with outside nuclear physicists who read and discuss proposals, listen to presentations, talk about the proposals with the people proposing them, and decide which experiments get beam time at Jefferson Lab. Only about  $\frac{1}{3}$  of experiments are actually approved by the Program Advisory Committee. An experiment can range from requiring 4 days of beam time to 200 days of beam time, depending on what is being measured.
- ◆ Once the experiment is approved, the real work starts. We do many computer simulations to figure out what we're going to see and exactly how we want to measure it. We make a detailed run plan: Where do we want to place the spectrometers? What momentum particles do we want to measure? How long do we need to measure in each location? How many events do we want to accumulate in each location? If necessary, we'll build new detectors and new targets.
- ◆ We're now ready to actually perform the experiment. We turn the beam on, we turn the detectors on, and the electron beam hits a target. Hundreds or thousands of times—maybe 10,000 times—per second, an electron in the beam hits a nucleus in the target. We get particles in our spectrometers.
- ◆ We want to measure specific events. To do that, we set up an experimental trigger that tells the computer to read out specific events from the detectors. The computer takes an event, such as a collision, and writes it to tape, accumulating not just thousands or millions, but sometimes billions, of events. The computer then reads out all of the detectors.

- ◆ The experiment doesn't stop. Beam time is a precious resource, so the beam runs 24 hours a day, 7 days a week. There are at least a few people in the experimental control room all the time. After a week, or a month, or 6 months of taking data, we have to analyze the data.
- ◆ First, we have to calibrate all of the detectors. When we read out the detectors, we get signals, such as time signals. We have to convert the time signals we get from the drift chambers to positions in the drift chamber, which have to be converted to momentum and angles of particles. We get pulsed information: How big was the signal from the Cherenkov counter? We have to convert that to particle information: Was it an electron or wasn't it an electron?
- ◆ After months spent calibrating the detectors, we can finally analyze the data. We use information about the particles, such as energy and momentum, to reconstruct what happened before and during the collision.
- ◆ During the experimental process, we have to make sure that we don't fool ourselves. As scientists, we need to be very careful: If we know the answer that we want to get from an experiment, we're more likely to get that result, so we have to set up safeguards to make sure that doesn't happen.
- ◆ Once we have analyzed the data and have the result, we have found out something new about the universe. We know something that nobody else in the world knows yet. The final step is to publish our results and go on to do the next experiment.

## Supplements

### READINGS

Gruppen, *Particle Detectors*.  
Jefferson Lab, “Jefferson Lab Virtual Tour.”

### QUESTIONS

- 1 Why do we need bigger spectrometers to measure higher-energy particles?
- 2 What determines the order in which we put detectors in spectrometers?

### ANSWERS

- 1 We measure the momentum of a charged particle by measuring how much its trajectory deflects when it travels through a magnetic field. The radius of the curvature of the particle's trajectory is proportional to its momentum. A more energetic particle has higher momentum and therefore a larger radius of curvature. If we double the momentum of a particle, then we need to double the distance it travels in a magnetic field to make it deflect the same amount. Therefore, we need bigger spectrometers with bigger magnets to measure higher-energy particles.
- 2 We put the detectors that measure particle positions first (e.g., wire chambers) so that the measured position is unaffected by particle interactions in other detectors. We then put the detectors with least material next so that the particles are most likely to pass through undisturbed and interact again with subsequent detectors. Thus, we put Cherenkov counters next, which contain only gas and very thin mirrors, and then relatively thin plastic scintillators, and then thick calorimeters.

# 11

## SCATTERING NUCLEONS IN SINGLES OR IN PAIRS

In this lecture, you will learn how we scatter electrons from the nucleus to learn more about it. Specifically, you will learn about 3 kinds of experiments: where we detect the scattered electron, where we detect the scattered electron and the proton it knocks out, and where we detect the scattered electron, the proton it knocks out, and a second proton or neutron. ◆

## Detecting the Scattered Electron

- ◆ In electron-scattering experiments, the electrons come down the beam pipe, hit a target in the middle of the scattering chamber, and then bounce off in all directions. The electrons are detected in the high-resolution spectrometer in Hall A at Jefferson Lab, which has a few quadrupoles to focus the electrons. Then, the dipole bends the electrons up to the particle detectors in the shielding hut at the top of the spectrometer. The higher-momentum electrons bend less; the lower-momentum electrons bend more. We have now detected the electron momentum in the high-resolution spectrometer.
- ◆ To do an experiment, we select the beam energy we want, the target—for example, if we are studying carbon, we would use a thin slice of [graphite](#)—and the angle of the spectrometer, which determines how hard the electrons we're detecting hit a carbon nucleus.

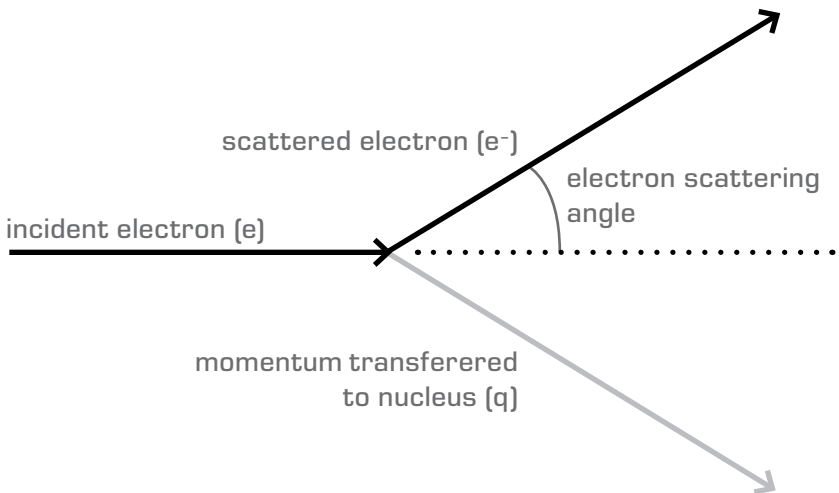

- ◆ For example, if the spectrometer is in a very forward angle, then the electron enters and scatters just a tiny bit, and it doesn't hit the nucleus very hard. On the other hand, if we put the spectrometer at a much larger angle, then the electron has to come in and bounce off at a large angle. In that case, it transfers much more momentum to the nucleus. The momentum transfer ( $q$ ) is what we're interested in.
- ◆ Next, we want to study how much energy the electron transfers to the nucleus. Where does the energy go? The energy goes into 2 things: the kinetic energy of the recoiling particles and the **excitation energy** of the nucleus. How much is the minimum amount of energy we can transfer?
- ◆ The electron hits the carbon nucleus, bounces off, and transfers momentum. This is kind of like a ping pong ball hitting a tennis ball: The tennis ball is going to recoil; it's going to be moving.
- ◆ Kinetic energy is  $\frac{1}{2}$  times mass times velocity squared:  $KE = \frac{1}{2}mv^2$ . But because we're dealing with momentum, kinetic energy is  $\frac{1}{2}$  times the momentum transfer squared divided by the mass of the nucleus:  $KE = \frac{p^2}{2m_A} = \frac{q^2}{2m_A}$ .
- ◆ The mass of the nucleus is very big, so we're not transferring a lot of energy to the nucleus when the electron just hits it and it recoils elastically. If we transfer more energy than that, then we can make the nucleus ring like a bell—we can excite the nucleus to excited states, which are the shell-model states. If we provide even more energy to the nucleus, we can make the nucleus vibrate as a whole—which are giant resonances. If we transfer even more energy, we can knock a single proton or neutron out of the nucleus.
- ◆ What happens if the electron, instead of scattering from an entire carbon nucleus, just scatters from a single proton? If we put in a hydrogen target and look at the electrons scattering from the proton, the electron comes in and we detect it at a certain angle, know the momentum transfer, and therefore know the kinetic energy ( $\frac{1}{2}$  times

the momentum transfer squared divided by the mass). The mass of 1 proton is 12 times smaller than the mass of carbon, so 12 times as much energy is transferred.

- ♦ The elastic peak is all the way on the left of the energy transfer diagram, and the discrete resonances and giant resonances are to the right of the elastic peak. There is also another peak corresponding to scattering from a proton or a neutron in the nucleus.

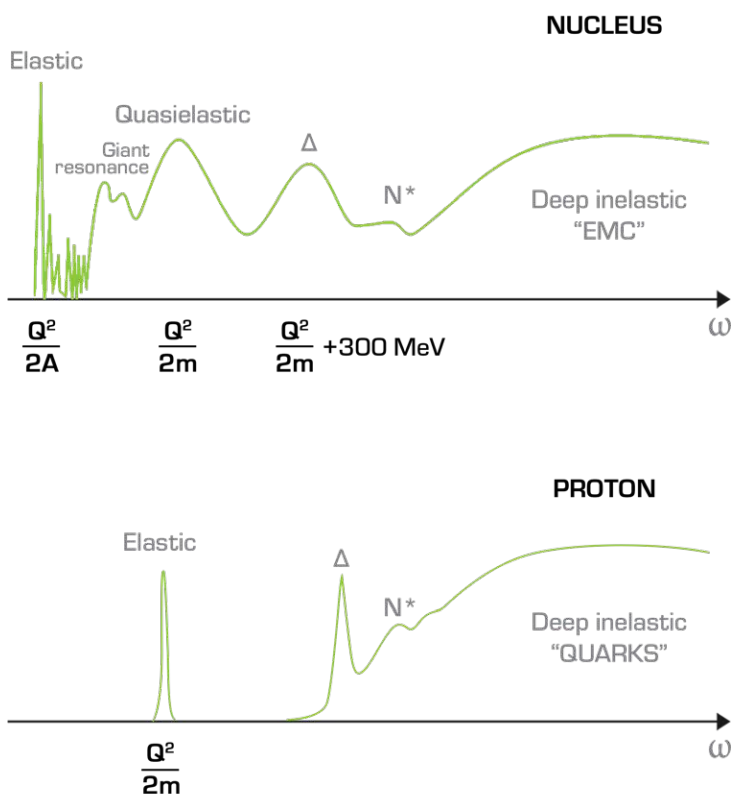

- ◆ We want to know the number of electrons that scattered elastically, that scattered to each of those different discrete states that excited the nucleus to a giant resonance, or that scattered elastically from a proton or a neutron in the nucleus.
- ◆ However, when an electron scatters from a proton or a neutron in the nucleus, instead of scattering from a proton in hydrogen, that proton or neutron in the nucleus is moving, so we can use information about what the quasielastic peak (because it's not quite elastic) looks like for electron scatter and for proton in carbon, versus what the elastic peak looks like, when the electron just scatters from a proton in hydrogen.
- ◆ When the number of electrons is plotted, we see that they transfer different amounts of energy to the nucleus. Instead of a very sharp peak, corresponding to electrons scattering from protons that are moving, we see a broader peak. The peak is also shifted a little because the protons and neutrons are bound in the nucleus—there's a binding energy. The peak is broad because the protons or neutrons in the nucleus are moving. How does that happen?
- ◆ If you hit a proton, you transfer momentum to the proton, and the proton is already moving in that direction. In that case, you're going to end up with a much faster proton; it will have higher momentum. The kinetic energy of that proton is its momentum squared divided by twice the mass:  $q^2/2m$ . You can transfer a lot more energy to it.
- ◆ On the other hand, if the proton is traveling toward the electron, then the electron transfers the momentum and you end up with a slower-moving proton. This means that when it comes out of the nucleus, the momentum squared divided by twice the mass ( $q^2/2m$ ) is much smaller. You're transferring less energy. And that's going to broaden the peak.

- ◆ The simplest model of protons and neutrons moving in the nucleus is the Fermi gas model, in which these particles move with all possible momenta—from 0 up to a maximum. If the proton or neutron is moving away from the electron, then it will have a greater momentum when it leaves the nucleus—more energy. The momentum transfer plus the Fermi momentum gives the maximum momentum, which is the maximum energy the electron can transfer.
- ◆ On the other hand, if the electron transfers its momentum and the proton is moving exactly opposite of the electron, then the proton momentum is the momentum transfer minus its initial momentum. And if it's moving with the Fermi momentum, that gives us the minimum kinetic energy of the proton or neutron and the minimum energy transfer.
- ◆ What about for protons and neutrons in between? If they are moving perpendicular to the momentum transfer, then they end up with a momentum that is at a different angle. There are many protons and neutrons that come out with about the same momentum as the momentum transfer.
- ◆ Very few electrons transfer the minimum possible energy, and very few electrons transfer the maximum possible energy. But many electrons in the middle transfer the average kinetic energy. And that gives us the shape of the quasielastic peak. It's rounded like a parabola.
- ◆ If we know the probability for an electron to scatter from an individual proton and from an individual neutron, then the total area of the quasielastic peak should correspond to the total probability for an electron to scatter from those individual protons and neutrons.
- ◆ The Fermi gas model does a very good job of describing the data all the way from a really light nucleus—such as lithium, with only 6 or 7 protons or neutrons—all the way up to lead, with 208 protons and neutrons.

## Detecting the Scattered Electron and the Proton

- ◆ In addition to detecting the electron, we want to detect the proton, too. Detecting the neutron is usually too difficult, so we measure protons and assume that neutrons do what protons do. Protons are charged particles, which means that we can use spectrometers and detectors to measure them.

---

The first coincidence experiment—in which the electron and the proton were detected in coincidence—was done with zinc-sulfide screens, which gave off little flashes of light when a particle hit it. Physicists looked at those screens in a darkened room, with dark-adapted eyes, to see those flashes.

To make sure that the particles were detected at the same time and to avoid having the physicists' results influence each other, the physicists had a clicker that was connected by a wire to somebody in another room, who wrote down when each of the clickers were pushed, indicating that a particle was detected.

- 
- ◆ To detect the electron and the proton, there are 2 high-resolution spectrometers in Jefferson Lab's Hall A. The electron hits the target—for example, carbon—and we position the electron spectrometer to detect the electrons that bounce off of it at a particular angle and position the proton spectrometer at the angle where the electron transfers momentum. Alternatively, we could do the same experiment in Hall B, with the large-acceptance spectrometer, which will detect the proton and the electron in the same spectrometer at the same time.

- ◆ How do we know that the electron and the proton came from the same interaction? We measure the difference in the arrival time of the electron in its spectrometer and the arrival time of the proton in its detectors. For each event, we plot the time difference of the 2 particles. When the electron and the proton came from the same event, there is a large spike on the time-difference spectrum.

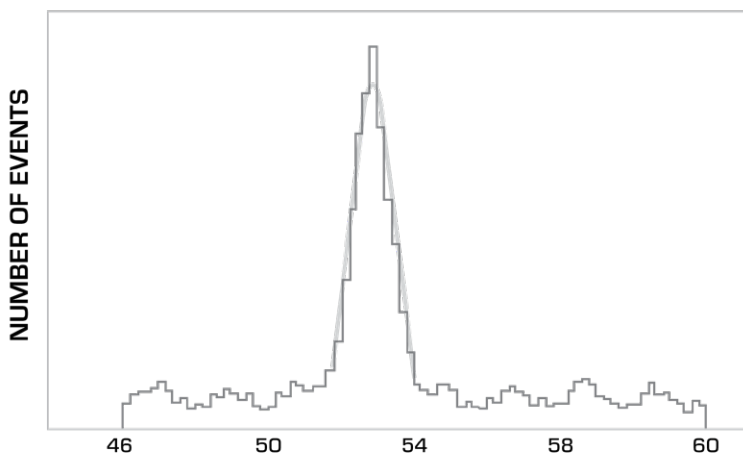

- ◆ Next, we want to reconstruct the proton's initial state. To do this, we plot the proton energy on the vertical axis and the electron energy on the horizontal axis. We make this new quantity called the missing energy, which is the energy transfer minus the proton kinetic energy:  $E_{\text{miss}} = E_{\text{beam}} - E' - T_p$ , where  $T_p$  is the proton energy,  $E'$  is the electron energy, and  $E_{\text{beam}}$  is the beam energy.
- ◆ The difference between the momentum that the electron hit the proton with and the momentum that the proton comes out of the nucleus with is the missing momentum, and it is very close to the momentum that the proton had before we hit it.

## Detecting the Scattered Electron, the Proton, and a Second Nucleon

- ◆ Distributions of missing momentum are beautifully well predicted and calculated. Energy distributions are also very well predicted and calculated. But when we compare the number of protons that we see with the number of events that the calculations predict that we should see, we only see  $\frac{2}{3}$  the number of protons that we expect.
- ◆ To look for the missing protons, we move the proton spectrometer to a larger angle, and then to a larger angle, and so on, and look for protons with larger and larger initial momentum. Then, we make a plot for each of those spectrometer angles—each of those proton initial momenta—and look at the missing energies.
- ◆ We see many events where there are very large missing energies, which means that we have to be knocking out more than 1 proton or neutron. To find those extra knocked-out nucleons, we need another detector. We can either use a large-acceptance spectrometer that detects all of the particles at once, or we can put a third large-acceptance spectrometer—in addition to the electron spectrometer and the proton spectrometer—in Hall A to detect the extra nucleon.
- ◆ We need to be able to detect both protons and neutrons because we don't know what's carrying away that energy and momentum, so we use a medium acceptance detector—a magnetic spectrometer called BigBite—and instrument it to detect protons. We put layers of scintillator detectors at the back, detect the protons that are bent through the dipole, measure their momentum in position with the scintillators, and figure out what their momentum and angle was.

- ◆ But we also have to detect neutrons. How do we do that? Because neutrons aren't affected by the magnetic field, they don't interact very much. That's a disadvantage, but it's also an advantage because it means that we can put a neutron detector behind BigBite. The protons enter BigBite and go upward to the detectors, while the neutrons go straight through and hit the neutron detectors behind. The neutron detectors are in the Hall A Neutron Detector (HAND).

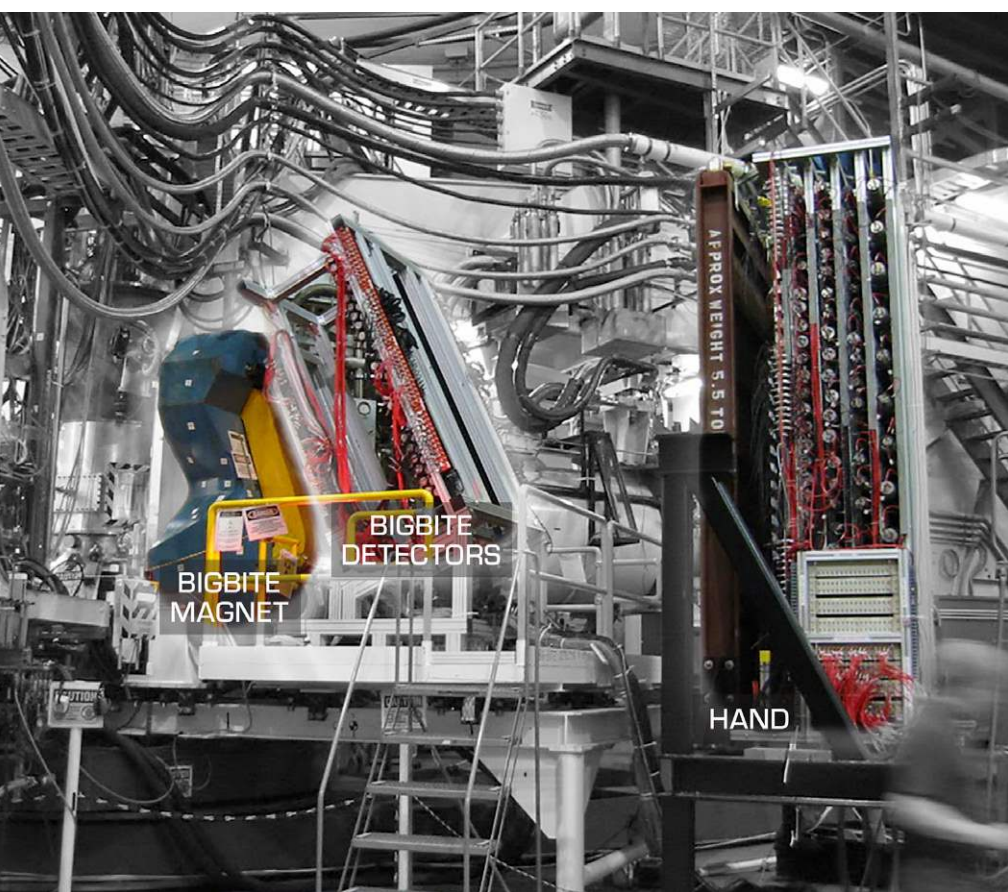

- ◆ How do we reconstruct the momentum of the neutron? We can't use the magnetic field. We have to use timing. We know what time the electron and the proton left the target; we know what time the neutron was detected at the target. The time difference between when the interaction occurred and when we detected the neutron tells us how long it took the neutron to get from the target to the detector. We know the time and the distance, from which we can measure the velocity.
- ◆ To find out which particles are carrying away the momentum and energy, we place BigBite, with HAND behind it, in the direction of the missing momentum. And it turns out that the missing momentum is always carried by a single proton or neutron. This is very surprising, because that momentum could've been carried by the nucleus as a whole or by a bunch of protons and neutrons. The fact that it's carried by a single proton or neutron tells us that we've got a proton-neutron or a proton-proton pair, where they're moving at very high momentum in respect to one another, the proton is knocked out, and the rest of the momentum is carried away by the second proton or neutron.
- ◆ Another thing that's surprising is that more than 90% of the time, that second nucleon is a neutron, and about 5% of the time, the second nucleon is a proton. This tells us that about 80% of the nucleons are at low momentum in shell-model orbitals but that the other 20% are in pairs that have high momentum.
- ◆ The fact that these pairs have high momentum tells us that they're at a short distance from each other. This tells us 2 things about these short-range pairs: Their density is much higher because they're much closer to each other, and the quarks (which protons and neutrons are made up of) are overlapping with each other.
- ◆ The shell model is still a useful approximation; it still describes about 75% of the protons and neutrons in the nucleus. But in the 21<sup>st</sup> century, we've learned that short-range correlations are a very important addition that need to be included.

## Supplements

### READINGS

Wilson, “Electron-Scattering Experiments Resolve Short-Range Correlations among Nucleons.”

### QUESTIONS

- 1 Can we make sure that an electron scatters elastically from a nucleus, like we can make sure that a billiard ball scatters elastically from another billiard ball?
- 2 Why are more scattering experiments done on carbon than on oxygen, even though oxygen is a doubly magic nucleus?

### ANSWERS

- 1 No. Electrons interact through quantum mechanics, and therefore we can only predict what will happen probabilistically. When we collide an electron with a nucleus, we cannot determine ahead of time whether it will scatter elastically with the entire nucleus, excite the nucleus to a specific excited state, scatter quasielastically with 1 nucleon in the nucleus, etc. All we can do is aim a beam of electrons at a slice of material and then select the electrons we are interested in afterward. For example, we can detect electrons that scatter quasielastically by placing our electron spectrometer so that it only detects electrons that scatter at a particular angle and a particular momentum.

2 This is because it is much easier to make a target containing carbon than a target containing oxygen. A carbon target can be a thin slice (0.1 millimeter) of graphite, which is pure carbon and has a high enough melting point that it is unaffected by the electron beam passing through it. In addition, it is a solid target with a constant thickness. A pure oxygen target would have to be either a gas (and therefore too thin) or a liquid (and therefore cooled to about  $-180^{\circ}\text{C}$  or  $-300^{\circ}\text{F}$ ). A solid target containing oxygen would have to contain other nuclei (e.g., beryllium oxide). At Jefferson Lab, physicists used a complicated waterfall target that involved using the hydrogen in the target as a calibration target.



# 12

## SEA QUARKS, GLUONS, AND THE ORIGIN OF MASS

**D**id you know that 99.9% of our mass—in fact, 99.9% of the entire visible mass of the universe—comes from the protons and neutrons in the nucleus of the atom. But only 1% of that mass comes from the masses of the 3 up and down quarks that make up the proton and the neutron. The famous Higgs boson explains mass, but it only explains the mass of those 3 up and down quarks. Half of that missing mass comes from antimatter. ◆

## Studying the Proton and the Neutron

- ◆ The proton is easier to study than the neutron because it's charged and it's stable. How do we know that the proton is not an elementary particle? An elementary particle is something like an electron or a quark that has zero size and no structure (as far as we know).
- ◆ Composite particles are made of elementary ones. They have structure and size. Protons, neutrons, and particles called pions are made of quarks. Nuclei are made of protons and neutrons, which are made of quarks. They all have structure and size.
- ◆ All particles have a wavelength, which is Planck's constant divided by the momentum:  $\lambda = h/p$ . The higher the momentum, the smaller the wavelength. This affects quantum behavior, such as tunneling and diffracting, but it's different from the inherent size of the object.
- ◆ How do we know that the proton is not a point particle like the electron, with zero size and no structure? The proton has a bigger magnetic field than expected from just its spin. The discovery of this was awarded the 1943 Nobel Prize in Physics to Otto Stern. But we also measure the size of the proton directly. We use the same technique—diffraction patterns in elastic electron scattering—to measure the proton radius as we use to measure the nuclear radius.
- ◆ We scatter 188-million-electron volt electrons from protons at the W. W. Hansen Experimental Physics Laboratory (HEPL) at Stanford. If we plot how many electrons bounced off at different angles—the cross section against the angle—there is a curve on the point proton, which is the reference cross section if the proton had zero size. But the data is smaller than that point proton curve at large angles. And we know from diffraction that if the slit is bigger, the cross section decreases faster. The bigger the slit, the narrower the pattern. The fact that the data decreased faster tells us that the proton has size. This earned the 1961 Nobel Prize in Physics for Robert Hofstadter.

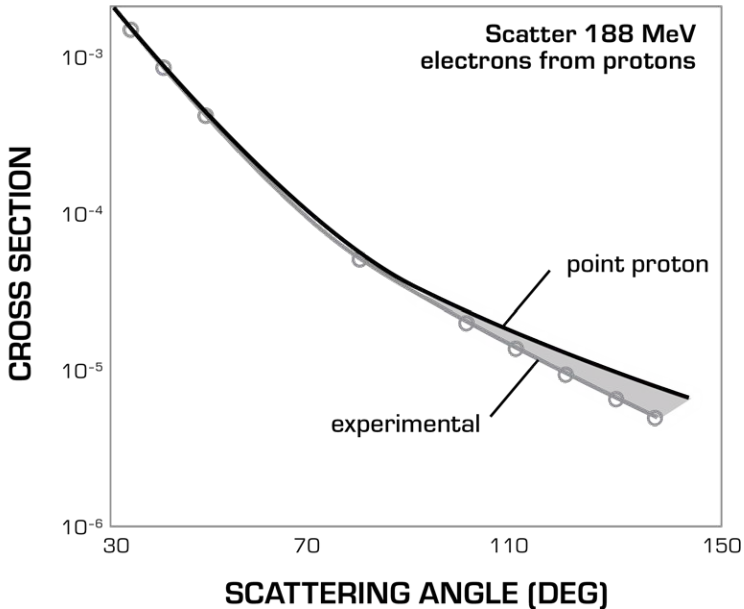

- ◆ How big is the proton? We can measure the electron-proton cross section and divide that by the point proton cross section to get the form factor. A point proton would have a form factor of 1 at all angles. The form factor decreases with the angle of scattering: The bigger the angle, or the higher the energy of the electrons, the faster the form factor decreases. That tells us that the radius of the proton is about 0.8 fermi, or  $0.8 \times 10^{-15}$  meters.
- ◆ Why do we care about the size of the proton? The size is related to the strength of the **quantum chromodynamic** (QCD) force that holds the quarks together: If the proton is bigger, the force is weaker; if the proton is smaller, the force is stronger.
- ◆ The mass of the proton is also related to the strength of the QCD force: A stronger force would probably give us a bigger proton mass; a weaker force would probably give us a smaller proton mass. The strong force—the force between protons and neutrons—derives from the QCD force between the quarks.

- ◆ Let's compare the electric and magnetic sizes of the proton. When an electron interacts with a proton, it can either interact electrically, with the charge of the proton, or magnetically, with charges moving in the proton. The electric interaction tells us about the position of the charges; the magnetic interaction tells us about the motion of the charges.
- ◆ Prior to 1998, measurements of the ratio of the electric to the magnetic form factor showed that it is flat as the electrons scatter to bigger and bigger angles, meaning that the electric and magnet sizes of the proton were the same. But starting in 1998, we found out that the ratio is not flat. Are the electric and magnetic sizes different? Are there relativistic effects? This was a huge surprise. This elastic scattering of particles from other particles—the kind that Ernest Rutherford did with alpha particles—is still interesting.

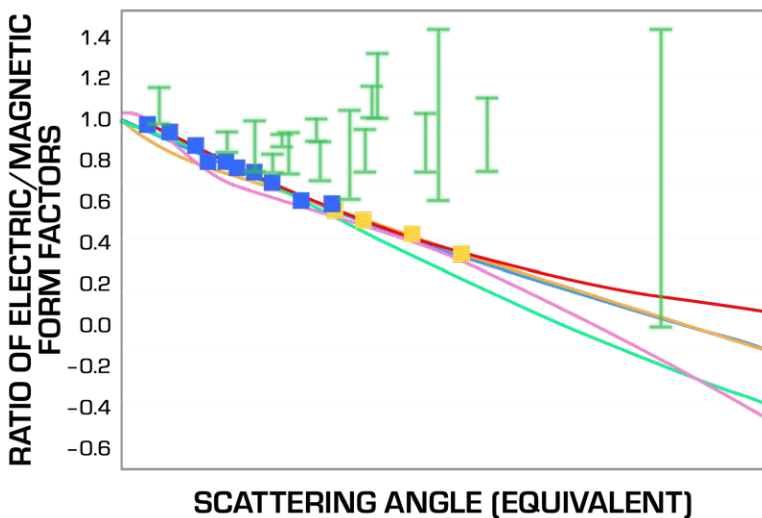

- ◆ Free neutrons decay, so we can't just make a target of neutrons to put in an accelerator. Instead, we measure scattering from deuterium, which has 1 proton and 1 neutron, and subtract scattering from hydrogen, which is what we get from scattering a proton. But we have to account for the fact that the proton in deuterium is moving around.
- ◆ We expect a similar neutron and proton structure. Both of them contain 3 quarks: The 3 quarks in the proton are up, up, down; the 3 quarks in the neutron are up, down, down. The charge is different, but the electromagnetic force is much weaker than the QCD force, and the difference in mass of the neutron and proton is only about 0.1%.
- ◆ But the neutron has no charge. How can we scatter electrons from it? It has no total charge, but the quarks in it are charged, so—just like a neutral atom has positive protons and negative electrons with a total charge of zero—the neutral neutron has 1 up quark with a positive charge of  $+\frac{2}{3}$  and 2 down quarks with a negative charge of  $-\frac{1}{3}$  each. The total charge on the neutron is 0.
- ◆ What's the charge distribution of the proton and the neutron? The neutron charge distribution is much smaller than the proton. The neutron charge distribution is positive at small radius and negative at large radius. The neutron looks kind of like there's a proton in the middle, circled by a negative pion.

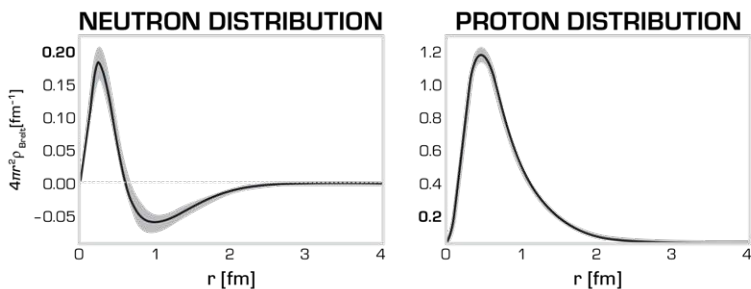

## Excited States

- ◆ The nucleus has excited states. Does the proton have excited states, too? Just like with the nucleus, where we plot the cross section versus the energy, here we plot the cross section versus the missing mass. We know the energy of a particle relativistically: energy squared is equal to its momentum squared plus its mass squared. That means that the mass squared is equal to the energy squared minus the momentum squared, so the energy is equal to the mass of the proton plus however much energy we gave it. The momentum of this excited state is equal to however much momentum we gave the proton when we bounced an electron off it. This tells us the excited mass of the proton.
- ◆ We look at the cross section, which is the probability of something happening, and plot it versus the mass of whatever we scattered from. We see bumps in the cross section corresponding to proton excited states—just like we see bumps when we scatter electrons from the nucleus corresponding to nuclear excited states. Unlike in the nuclear case, where the excited states are really narrow, for the proton, the excited states are really wide in energy.

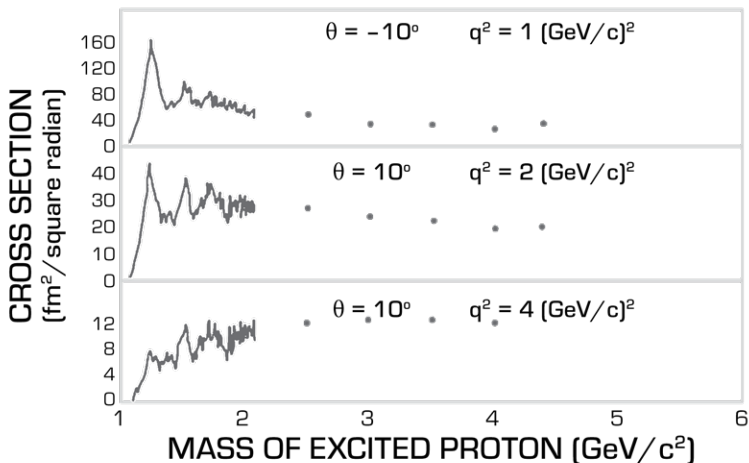

- ◆ Can we see the quarks inside the nucleus? We need better spatial resolution, shorter wavelengths, and higher-energy electrons to answer this question.
- ◆ The Stanford Linear Accelerator Center (SLAC), which was built in 1962 and became operational in 1966, is a 2-mile-long accelerator that is in a straight line because electrons lose energy when they go in circles. Small-aperture spectrometers, similar to the ones at Jefferson Lab, were used to detect electrons and other particles knocked out in high-energy collisions.
- ◆ It turns out that the cross section has no bumps for larger masses. How does that cross section change when you transfer more momentum to the nucleus (when the angle gets bigger)? The probability of elastic scattering decreases dramatically as more momentum is transferred (to the nucleus or to the proton) or as the electron scatters at a bigger angle.
- ◆ When we do **elastic scattering** at very large excitation energies of the proton, the cross section is flat. That tells us that instead of scattering from an extended object (so that you get diffraction patterns), there is scattering from point particles in the proton. This tells us that there are quarks in the proton. This discovery earned the 1991 Nobel Prize in Physics for Henry Kendall, Richard Taylor, and Jerome Friedman.

## Quarks and Gluons

- ◆ There are up and down quarks (more exotic particles have strange, charm, top, and bottom quarks). The spin of the quarks is  $\frac{1}{2}$ . They have a fractional charge: The up quark is charged  $\frac{2}{3}$  while the down quark is charged  $-\frac{1}{3}$ . They have 3 colors (red, green, and blue); this is the QCD version of charge. The antiquarks have anticolors; each antiquark has 1 anticolor.

- ◆ There are 2 ways to combine colors to make the color neutral. We can add 3 quarks in a proton or neutron (red plus green plus blue gives white), or we can combine a quark and an antiquark in a pion (i.e., green quark and antigreen antiquark).
- ◆ How do 3 quarks make a proton? A proton is up, up, down; a neutron is up, down, down. What about other combinations of quarks? We can look at possible combinations of up, down, and strange quarks: 1 up, 1 down, 1 strange makes a particle called a lambda [ $\Lambda$ ]; 1 down, 1 down, and 1 strange makes a particle called the sigma [ $\Sigma^-$ ]; and 1 down, 1 strange, and 1 strange makes a particle called a cascade [ $\Xi^-$ ].
- ◆ Quarks were invented to explain the multiplicity of these particles. Nobody has ever seen a quark.

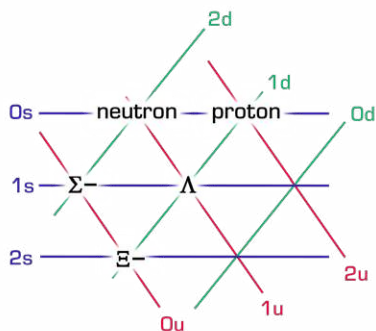

- ◆ How are these 3 quarks (the up, the up, and the down) distributed in the proton? There are more up quarks than down quarks in the proton—which is good—but there are an infinite number of quarks in the nucleus. How can this be? What are these extra quarks (beyond the up, up, down) in the proton?
- ◆ The QCD force is carried by gluons between the quarks. Quarks are always exchanging gluons to keep in touch. There are always gluons in the proton or neutron. But quark-antiquark pairs can only exist for short periods of time. These are called **virtual particles**. So, the proton is made up of 2 up quarks and 1 down quark, plus gluons that help keep them in touch, plus virtual quark-antiquark pairs.

- ◆ How many quarks are there in the proton? It depends on the wavelength (the resolving power) of the electron or muon we are using to study it. The shorter the wavelength, the more detail we see—more quark-antiquark pairs and more gluons.
- ◆ There can be an infinite number of quarks and antiquarks, as long as they carry very little momentum, because the momentum fraction has to add up to 1. So, we distinguish between the valence quarks—which are the 2 up quarks and the down quark that make it a proton—and the sea quarks, which are the quark-antiquark pairs.
- ◆ How do we distinguish valence quarks from sea quarks? We have to use other reactions to measure antiquarks. Antiquarks can only be sea quarks. The total number of quarks comes from the 3 valence quarks plus all the sea quarks.
- ◆ There are exactly twice as many up quarks as down quarks in the valence quarks—which we know are 2 up quarks and a down quark. But what kind of sea quarks do we have? There are lots of up and down quarks in the sea, and they have a few million electron volts each. There are some strange quarks, with 100 million electron volts. There are very few charm quarks and almost no bottom quarks.
- ◆ But the quarks only provide half of the momentum of the proton. The rest of the proton momentum is carried by the gluons.
- ◆ The total mass of the valence quarks—the 2 up quarks plus 1 down quark—is only about 10 million electron volts, so it's only a few percent of the mass of the proton. That means that about 99% of each proton's mass is in the energy of the virtual sea quarks and gluons. About 50% comes from sea quarks and about 50% comes from the gluons. This comes from the details of QCD. Nucleons are 99.9% of the atomic mass, which means that 99% of our mass comes from quark-antiquark pairs and gluons. The biggest question in nuclear physics is why the

nucleus is made of protons and neutrons and not just quark soup. Why do protons and neutrons keep their identities in the nucleus? There are 2 approaches to looking at nucleons in the nucleus:

- 1 Protons and neutrons are strongly interacting, often overlapping particles, so of course they are modified, with a different structure when they are in the nucleus.
  - 2 The average proton binding energy is 8 million electron volts, which is less than 1% of the mass. How will that affect an experiment using 80,000-million-electron volt electrons to measure proton structure? Of course, we won't see a difference.
- ◆ The European Muon Collaboration (EMC) discovered that quarks in heavier nuclei move more slowly than quarks in light nuclei, and the heavier the nucleus, the bigger the effect. This means that the nucleons in nuclei are modified.
  - ◆ What causes the **EMC effect**? When the size of the EMC effect for different nuclei is plotted against the probability of finding a fast-moving nucleon pair in the nucleus (short-range correlated pair), there is an almost perfect correlation. But correlation doesn't imply causation.
  - ◆ Are nucleons modified by being in a fast-moving short-distance pair? We know that at short distance, the nucleon-nucleon force is stronger. Experiments are being planned at Jefferson Lab to measure this.

Surprisingly, 99% of the proton and neutron mass—and therefore our mass—comes from the energy of a cloud of virtual particles.

## Supplements

### READINGS

- Collins, “Parton Distribution Functions.”  
Feltese, “Introduction to Parton Distribution Functions.”  
Friedman, “Deep Inelastic Scattering.”  
Kendal, “Deep Inelastic Scattering.”  
National Research Council, *Nuclear Physics*, p. 104–123.  
Taylor, “Deep Inelastic Scattering.”  
Wilczek, “The Origin of Mass.”

### QUESTIONS

- 1 Why do we say that a proton or a neutron is made up of 3 quarks when each can contain an infinite number of quarks?
- 2 Are quarks point particles, or are they composed of still-smaller particles?

### ANSWERS

- 1 The proton and neutron are made up of 3 quarks plus a large number of quark-antiquark pairs. The 3 valence quarks combine to provide the charge and spin of the proton (up, up, down) and neutron (up, down, down). Each quark-antiquark pair has a total charge of zero and a total spin of zero. However, the quark-antiquark pairs do contribute to the mass of the proton and neutron.
- 2 We don’t know. So far, there is no evidence that quarks have size or that they are composed of smaller particles. However, physicists are still looking.

# 13

## NUCLEAR FUSION IN OUR SUN

**O**ur Sun is a fusion-powered nuclear reactor, providing the Earth with 100,000 terawatts of solar power. This provides direct power for photosynthesis in plants and for solar panels, indirect power for wind and hydroelectricity, and the energy stored in coal, oil, and gas. This lecture will pull together our knowledge of nuclear masses, forces, decays, and reactions and apply that to our favorite nuclear reactor: the Sun. ◆

## Stellar Formation and Solar Characteristics

- ◆ Stars form from the gravitational collapse of interstellar gas clouds, which are mostly hydrogen. The gravitational energy of the collapse, as the hydrogen falls inward, goes to radiation and to heating up the gas. About half of the energy is radiated out; the other half heats up the gas. If the mass is more than 0.08 of the mass of the Sun, then the temperature gets hot enough for fusion, and the hot cloud of gas becomes a star.
- ◆ Solar structure is determined by a number of competing physical processes:
  - Pressure balance: The weight of the gas above is balanced by the pressure of the gas below. As you go deeper in the Sun, the weight becomes bigger, so the pressure becomes bigger—just like water in the ocean or air in the atmosphere.
  - Temperature gradient: All the power is generated in the core, but it is radiated outward from the surface, so the energy flows from hot to cold, which means that the core is much hotter than the surface.
  - Power balance: When the star is in steady state, just like the Sun, all of the power generated in the core is radiated from the surface. This power is carried away by photons as mostly visible light. It takes hundreds of thousands of years for each photon to reach the surface from the core.
- ◆ How does a photon (gamma ray) reach the surface? The gas is very opaque, and the photon is repeatedly absorbed and reemitted. The reemission is random. This is called a random walk. The distance traveled by the photon increases with the number of steps, but it increases very slowly.

- ◆ The Sun is 93 million miles, or 150 million kilometers, away. The diameter of the Sun is 1.5 million kilometers. The radius is 0.7 million kilometers. To cover this distance, a photon needs 1 trillion squared, or  $10^{24}$ , random steps. At this rate, it takes a photon about 100,000 years to reach the surface.
- ◆ All of these collisions **thermalize** the photons. This means that the spectrum of the photons depends on the temperature. It gives us a blackbody spectrum of light. This means that the distribution of photons and energy depends only on the temperature. It tells us the surface temperature, but it doesn't tell us anything about how the energy is made.
- ◆ The radius of the Sun is 7000 kilometers. The mass is  $2 \times 10^{30}$  kilograms. The temperature on the surface of the Sun is about 6000 Kelvin. The central temperature is about 16 million Kelvin, which corresponds to an energy of the particles in the Sun of about 1500 electron volts. This number is much less than the nuclear binding energies of 8 million electron volts per nucleon.

In 1920, precise measurements of atomic masses led Sir Arthur Eddington to suggest the possibility of nuclear fusion in stars.



**SIR ARTHUR EDDINGTON**

1882–1944

- ◆ Where does the Sun's energy come from? Could it come from chemical energy, the energy stored in molecules? Chemical energy is about 100 million times less than the energy stored in nuclei. This could only power the Sun for about 10,000 years. What about gravitational energy? This is the energy released by all the mass falling inward. Even gravitational energy could only power the Sun for about 1 million years.

## The Power of Nuclear Fusion

- ◆ The Sun's power comes from **nuclear fusion**. The Sun is mostly hydrogen and some helium. The curve of binding energy shows that if we fuse lighter elements to form heavier ones, it releases energy. The biggest energy gain comes from fusing 4 protons into helium-4; almost 1% of the mass of the hydrogen is converted into energy when it fuses to helium.
- ◆ How do we make this happen? We need a high enough temperature so that the protons can fuse, and we need enough density so that there are enough protons to fuse. Nuclear fusion only happens in the core of the star, where the temperatures and densities are high enough.
- ◆ How do stars fuse protons to helium, and where do the neutrons come from? Let's start with the protons. Two protons can combine to form helium-2, which is extremely unstable and most of the time just falls apart again. Some of the time, helium-2 decays to a deuteron, a positron, and a neutrino.
- ◆ The total energy of 2 protons going to the deuterium is twice the mass of the proton, minus the mass of the deuteron, minus the mass of the positron, or about half a million electron volts. If we include the energy

we get from the positron finding an electron and annihilating and subtract the energy carried off by the neutrino, the total energy gained is about 1.2 million electron volts.

- ◆ But this is very unlikely to happen, for a few reasons. The protons repel each other electrically. The energy barrier is about 1.6 million electron volts. The protons move with thermal energy. The central temperature of about 16 million Kelvin means that they each have an energy of about 1500 electron volts. The proton kinetic energy is about 1000 times less than the electrical repulsion energy.
- ◆ The protons get close enough to fuse by quantum tunneling—just like alpha particles tunneling out of an unstable nucleus. In this case, the energy is 1000 times too low, so they need to tunnel a distance of about 1000 times the proton radius. This is very unlikely. This is why we need very high temperatures: As the temperature increases, the probability of fusion increases dramatically.
- ◆ So, 2 protons fuse into helium-2, which is very unstable. It decays by the strong decay into 2 protons almost instantly, but a tiny fraction of helium-2 decays by the weak decay to a deuterium nucleus, a positron, and a neutrino. So, it takes a very long time for 2 protons to make a deuteron. Fortunately, there are a lot of protons in the Sun, so this reaction does occur. Once there's a deuteron, it gets hit by another proton, becomes a helium-3, and emits a photon very quickly. So, there is a bottleneck in making the deuterons.
- ◆ What happens to helium-3? There are 2 branches. In the PP-I chain (PP stands for proton-proton), which happens 69% of the time, a helium-3 and a helium-3 hit each other, combine, and make helium-4 and 2 protons. The net result of 6 protons combined and ended up as a helium-4, 2 protons, 2 positrons, 2 neutrinos, and 2 photons. So, there's about 24.7 MeV, plus the positron annihilation energy, minus the neutrino escape energy, leaving us with about 26 MeV.

- ◆ The other 31% of the time, the helium-3 hits a helium-4 and makes a beryllium-7 plus a photon. This branch splits again. In the PP-II chain, which happens 30.9% (out of 31%) of the time, the beryllium-7 beta decays to a lithium-7, a positron, and a neutrino. The lithium hits a proton and becomes 2 helium-4 nuclei. The net result is 4 protons, which makes a helium-4 plus 2 positrons, 2 neutrinos, and 2 photons. This makes about 24.7 MeV of energy, plus the energy of the positron annihilation, minus the energy the neutrinos carry off with them, giving us about 26 MeV. This second neutrino has 0.8 MeV.
- ◆ In the PP-III chain, which happens 0.1% of the time, the beryllium-7 absorbs a proton, becomes boron-8, and gives off a photon—a gamma ray. The boron-8 then immediately decays into 2 helium-4 nuclei plus a positron and a neutrino. So, the net result is the same energy: 4 protons make a helium-4 nucleus, 2 positrons, 2 neutrinos, and 3 gamma rays. The same energy goes in, but the neutrinos are carrying off a lot more energy. The net result is 19.3 MeV. This second neutrino has a lot of energy, about 7.2 MeV. It's only 0.1% of the total fusions, but it's important for detecting solar neutrinos.
- ◆ How do we know this? We can measure reaction rates and cross sections in accelerators. This is difficult, because the rates are tiny at these very low energies. We need to measure at larger energies and extrapolate down to the lowest energies. We can calculate the reaction rates in cross sections using nuclear models and then use these cross sections to help build solar models.
- ◆ How can stars avoid the bottleneck with 2 protons having to wait a really long time to go to a deuterium, a positron, and a neutrino? Stars can use carbon, nitrogen, or oxygen as a catalyst. This is called the **CNO cycle**.

The Sun converts 4 megatons of mass to energy every second, and 500 megatons per second of hydrogen is converted to helium.

- ◆ Which is better: the **PP chain** or the CNO cycle? It depends on the temperature of the star. Carbon has a lot more electrical repulsion because it has more charge, so the protons need more energy to penetrate and tunnel into the carbon nucleus. Our Sun gets more energy from the PP chain, but if the mass were greater, the star would get more energy from the CNO cycle.
- ◆ Both the proton-proton and CNO processes are slow. The proton-proton to deuterium is especially slow, even in the Sun. This is why the Sun can shine for billions of years. Fusion reactors on Earth will never work this way; they need to consume their fuel much faster.

## How Fusion Affects Stellar Lifetimes

Bigger stars have much higher internal temperatures. The core temperature can be up to 10 times higher (instead of 16 million Kelvin, it can be 150 million Kelvin). The higher temperature means that it's much easier for protons to quantum mechanically tunnel. There is a much higher reaction rate. As the temperature increases from, for example, 20 to 100 million Kelvin, the reaction rate increases by a factor of about  $10^{10}$ . Bigger stars burn a lot faster and die younger.

Our Sun's lifetime is estimated at about 15 billion years. Our Sun is only 5 billion years old now, which means that it's fairly young.

## Detecting Solar Neutrinos

- ◆ How do we know that there is nuclear fusion in the Sun?
  - The Sun is primarily hydrogen and helium, which we know from spectroscopy.

- Nuclear fusion is the only known source with enough energy to last the Sun's lifetime, because the strong force is so much greater than the electromagnetic force.
- Simulations of the Sun, including known nuclear physics from Earth, describe the Sun's surface characteristics well. These models tell us several things about the inside of the Sun: that the density is about 150 tons per cubic meter at the center (almost 10 times the density of gold), the pressure is about 100 billion atmospheres at the center of the Sun, and the temperature is about 16 million Kelvin.
- ◆ But we still want direct evidence of nuclear processes from the solar interior. Maybe we can detect some of the solar neutrinos.
- ◆ There are  $10^{38}$  neutrinos emitted by the Sun every second. By the time these neutrinos reach the Earth, they are spread out over a sphere whose radius is the distance from the Earth to the Sun. This means that there are about  $10^{15}$  neutrinos for every square meter per second, which means that about 1 quadrillion neutrinos are passing through each of us every second. Fortunately for us, they rarely interact.
- ◆ All 3 proton-proton chains give low-energy neutrinos (less than 0.5 MeV) from the proton-proton going to a deuterium, a positron, and a neutrino. The PP-II chain gives a 0.8 MeV neutrino from the beta decay of beryllium-7 to lithium-7. The PP-III chain gives a 7 MeV neutrino from boron-8 going to 2 helium-4 nuclei, plus a beta, plus a neutrino. That only happens 1 in 1000 times. But those high-energy neutrinos are the ones we want to detect.
- ◆ How do we detect these elusive neutrinos? One way is to make a detector with a lot of chlorine-37 (fortunately, natural chlorine is about  $\frac{1}{4}$  of chlorine-37). Then, we look for argon-37 atoms made by the reaction where a neutrino hits chlorine-37 and basically inverse

beta-decays to make argon and a positron. This is sensitive to neutrinos with energy greater than about 0.8 MeV, and the cross section increases rapidly with energy.

- ◆ How much chlorine do we need? The cross section is about  $10^{-50}$  square meters for each chlorine-37 nucleus, and we have  $10^{15}$  neutrinos per square meter per second, so the interaction probability for 1 chlorine-37 nucleus (assuming that 15% of the neutrinos have 0.8 MeV or more) is  $10^{-36}$  interactions per second. That means that we need  $10^{36}$  chlorine nuclei to measure 1 neutrino per second.
- ◆ The solar neutrino unit (SNU) gives 1 interaction per  $10^{36}$  target nuclei per second, which is about 60 million tons of chlorine. Ray Davis conducted a very difficult experiment that continued for 25 years and still only saw about  $\frac{1}{3}$  of the expected number of neutrinos from the Sun.
- ◆ From this and other neutrino experiments, particle physicists have learned that neutrinos are weird and can oscillate from one kind of neutrino to another, that our simulations of the Sun predict the measured neutrino energy distribution, and that our Sun is indeed powered by nuclear fusion.

## Supplements

### READINGS

“Fusion,” *Nobelprize.org*.

Henley and Garcia, *Subatomic Physics*, section 19.3.

LeBlanc, *An Introduction to Stellar Astrophysics*, sections 6.1–6.5.

Mackintosh, *Nucleus*, chap. 9.

Rosen, “Ray Davis.”

Thomson (Lord Kelvin), “On the Age of the Sun’s Heat.”

## QUESTIONS

- 1 How does a star maintain a stable core temperature?
- 2 Why does increasing the core temperature of stars by a factor of only a few increase their power output by a factor of millions or billions?

## ANSWERS

- 1 If the temperature decreases, then the core contracts. This means that the protons are closer together so that the nuclear fusion rate increases. This releases more energy, increasing the temperature. On the other hand, if the temperature increases, then the core expands. This increases the distance between protons, decreasing the nuclear fusion rate. This releases less energy, decreasing the temperature.
- 2 This situation is very similar to the half-life of alpha decay (lecture 3). Alpha particles have to quantum mechanically tunnel out of the nucleus to decay. Protons have to quantum mechanically tunnel into the other proton to fuse. When the energy of the alpha particle increased, the distance that it had to tunnel out through the region of repulsion decreased. This exponentially increased the probability of decay, decreasing the half-life exponentially. If a star has a core temperature that is twice as large as that of the Sun, then its protons have twice the kinetic energy. This decreases the distance they have to tunnel in through the region of repulsion, which exponentially increases the probability of tunneling, exponentially increasing the proton-proton fusion rate.





# 14

## MAKING ELEMENTS: BIG BANG TO NEUTRON STARS

**T**he overall name for how our universe creates nuclei is nucleosynthesis, and there are 4 main processes: big bang nucleosynthesis, which made hydrogen and helium; fusion in ordinary stars, which made helium, carbon, and oxygen; cosmic-ray fission, in which fast protons collide with carbon to make nuclei skipped over in stars; and explosive processes, with supernovas or colliding neutron stars. ◆

## The Big Bang

- ◆ In 1929, Edwin Hubble observed that the spectral lines of stars in galaxies are redshifted, and the redshift increases linearly with distance. The raisin bread model is used to explain this. If you think of raisin bread rising—or expanding—each of the raisins is moving apart from each other. The farther a raisin is from another one, the faster they're moving apart.
- ◆ Using this model as a guide, we can extrapolate backward to the big bang, about 14 billion years ago, when the universe was very hot and exploding, but cooled as it expanded. The farther back in time we go, the smaller, denser, and hotter the universe is.
- ◆ What do these insanely high temperatures mean? Temperature is the average kinetic energy of a particle. This is 10,000 Kelvin, which is a kinetic energy of 1 electron volt. And that's the average; it's actually a wide distribution of energies. If the temperature is greater for a particle of twice its mass times the speed of light squared ( $2mc^2$ ), then it can make particle-antiparticle pairs.
- ◆ If the temperature is greater than the binding energy of a system, then the particles don't stay bound. If the temperature is greater than 10 electron volts, atoms fall apart. If the temperature is greater than 1 million electron volts, nuclei fall apart. And if the temperature is greater than 100 million electron volts, protons and neutrons start to fall apart. "Freeze out" is the term for when the temperature drops below these points and the particles are now stable.

The biggest explosion ever was making hydrogen and helium in the big bang, which was unlike any chemical or nuclear bomb explosion.

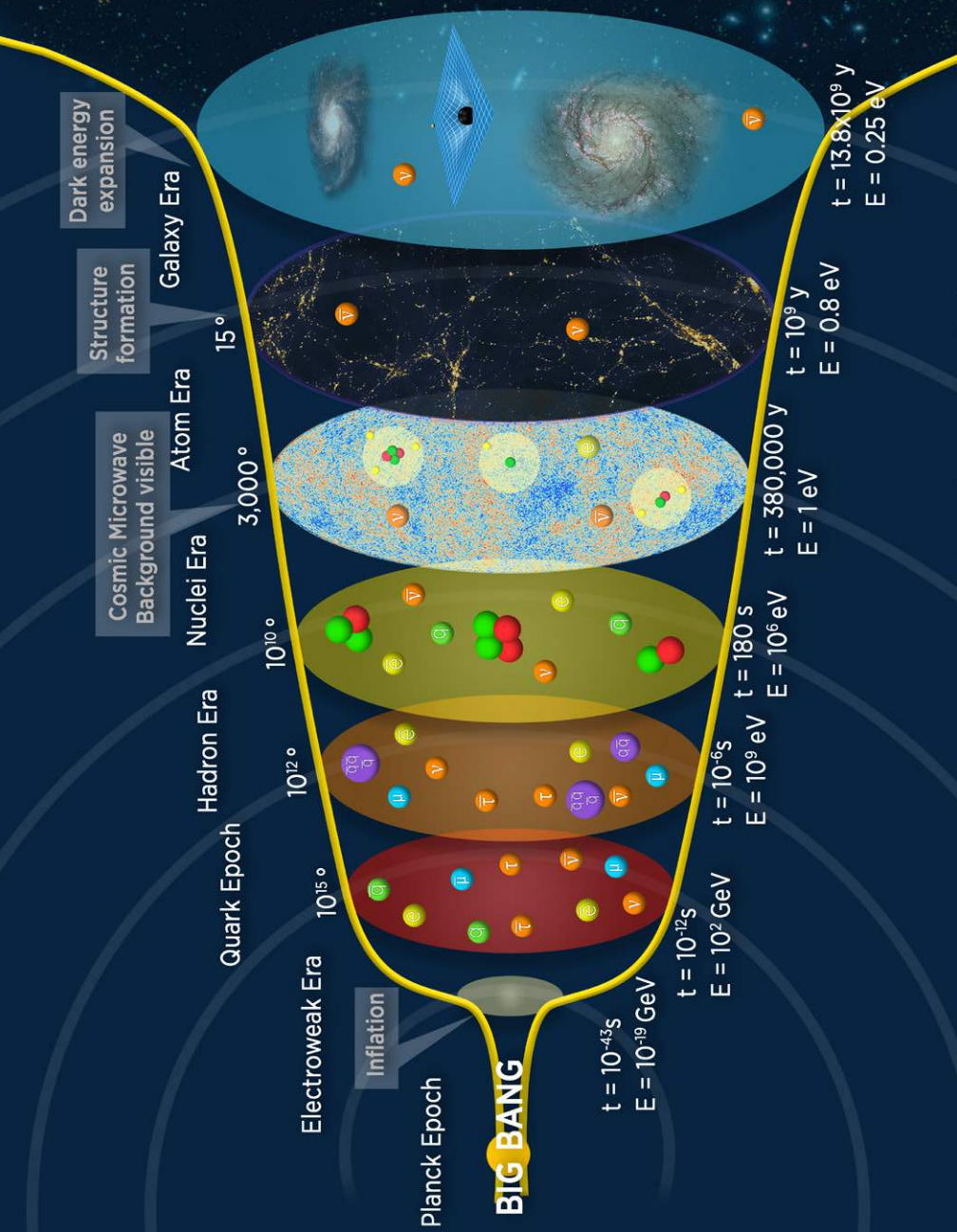

# BIG BANG

Planck Epoch

Inflation

Electroweak Era

Quark Epoch

Hadron Era

Nuclei Era

Atom Era

Galaxy Era

$t = 10^{-43}s$   
 $E = 10^{19} \text{ GeV}$

$t = 10^{-12}s$   
 $E = 10^2 \text{ GeV}$

$t = 10^{-6}s$   
 $E = 10^9 \text{ eV}$

$t = 180 \text{ s}$   
 $E = 10^6 \text{ eV}$

$t = 380,000 \text{ y}$   
 $E = 1 \text{ eV}$

$t = 10^9 \text{ y}$   
 $E = 0.8 \text{ eV}$

$t = 13.8 \times 10^9 \text{ y}$   
 $E = 0.25 \text{ eV}$

Dark energy expansion

Structure formation

Cosmic Microwave Background visible

$15^\circ$

$3,000^\circ$

$10^{10}^\circ$

$10^{12}^\circ$

$10^{15}^\circ$

- ◆ The big bang timetable shows what happened as the temperature dropped. We know this from modeling that incorporates the 4 forces of the standard model.
  - If the temperature was greater than  $10^{19}$  billion electron volts, it is unknown what happened. We need theories of quantum gravity that we don't have yet.
  - When the temperature had dropped to  $10^{14}$  billion electron volts, that was the time of cosmic inflation, when space expanded dramatically by an incredible rate.
  - When the temperature had dropped to 100 billion electron volts, then the forces—such as the strong force and the weak force—separate. At that time, there was a seething mass of electrons, quarks, gluons, etc., and it was the time of quark-gluon plasma.
  - When the temperature had dropped to 100 million electron volts (or 10 billion Kelvin) at about 1 microsecond after the big bang, quarks started clumping into protons and neutrons, which froze out. There are a lot more protons than neutrons because the proton has a smaller mass than the neutron, so it was more energetically favorable to make protons. All the protons (hydrogen nuclei) that exist today were made back then; they are primordial.
  - At about 3 minutes after the big bang, the temperature had dropped to about 100,000 electron volts. That's when nucleosynthesis began. Nuclei were now stable enough, and these are the kinds of reactions we can measure in accelerators.
  - About 30 minutes after the big bang, the temperature had dropped to 10,000 electron volts (or 100 million Kelvin), which is too cold for nucleosynthesis.

- At 300,000 years after the big bang, the temperature had dropped to 3000 Kelvin, or about 0.3 electron volts. That's when electrons and nuclei joined to form atoms.
- At 14 billion years after the big bang, the temperature of the universe is 2.7 Kelvin, or 2.7° above absolute zero, which is the temperature of the interstellar vacuum today.

## Nucleosynthesis

- ♦ To make nuclei from neutrons and protons, the neutron has to hit a proton and form a deuterium nucleus (heavy hydrogen) and give off a gamma ray. The neutrons have not yet decayed to protons because the lifetime of a free neutron is 15 minutes. The deuterium binding energy is only 2.2 MeV, so the temperature has to be much less than that or the deuterium nuclei will fall apart.
- ♦ Deuterium was made in big bang nucleosynthesis. If there is deuterium in stars, it gets destroyed because the stars are too hot.
- ♦ There are many subsequent reactions. A proton can hit the deuteron, making helium-3 plus a gamma ray. (There are more protons around, but it's more difficult for a proton to fuse with a deuteron.) A neutron can hit a deuteron, making tritium (even heavier hydrogen). A neutron could hit a helium-3 to make helium-4. A proton could hit a tritium to make helium-4. Or a deuterium could hit helium-3 to make a proton plus helium-4.
- ♦ There can also be heavier reactions. Tritium can hit helium-4, making lithium-7. Helium-3 could hit helium-4 and make beryllium-7, which then beta-decays to lithium-7. Or a proton could hit lithium-7, split

it up, and make 2 alpha particles—2 helium nuclei. This is very complicated. It depends on the temperature, density, and abundances. But almost all of the neutrons end up in helium-4.

- ◆ Why didn't heavier elements form? Heavier nucleosynthesis is almost blocked by the fact that there are no stable nuclei with 5 nucleons. There are also no stable nuclei with mass 8. This is because helium is so tightly bound itself, because it's at a magic number. There's also a relatively low density in the big bang, so a rare helium-4 would need to hit a very rare lithium-7 to make, for example, boron-11, which is even heavier.
- ◆ Let's pull together all of these processes and use them to model what happened during big bang nucleosynthesis. We will have 1 parameter—the proton and neutron density at the start of big bang nucleosynthesis—from which we will predict the abundances of helium-4, helium-3, deuterium, and lithium-7.
- ◆ There was 25% helium-4 because almost all of the neutrons ended up in helium-4. There was a 7-to-1 ratio of protons to neutrons, which is equivalent to a 14-to-2 ratio, which gives us 12 protons plus a helium-4, and that means that a quarter of the mass is helium-4. In addition, there were about 30 parts per million deuterium, about 10 parts per million helium-3, and about 300 parts per trillion of lithium.
- ◆ There is some conflict with the lithium number. If the universe had been denser—if there were more matter—then there would be less deuterium and less helium-3, because those would have been made into helium-4. And there would have been more lithium-7, because there would have been more chances for helium-3 to hit helium-4 and make beryllium-7, which would beta-decay to lithium-7.

- ◆ Heavier elements weren't made in the big bang. When a star exhausts its hydrogen, it gravitationally shrinks—because it has lost its fuel source—and becomes hotter and hotter, until it finds a new power source. That new power source is fusing helium-4.
- ◆ Helium-4 burning in stars starts at a temperature of 100 million Kelvin. We need enough helium-4 so that 2 things can happen: 2 helium-4s can come together and make an excited state of beryllium-8, but that lasts for about  $10^{-15}$  seconds, so we need enough helium so that a third helium can come along, hit the beryllium-8, and make an excited state of carbon-12, plus a gamma ray.
- ◆ That excited state of carbon-12 was predicted by Fred Hoyle to make it much more likely that 3 helium nuclei could come together at the same time to make carbon production possible. This is called the triple-alpha reaction, because 3 helium come together to make carbon-12 plus 3 gamma rays (from the decay of beryllium-8 and from the carbon excited states).
- ◆ This produces a lot less energy than 4 protons going to helium; in fact, the mass fraction is 10 times smaller. It also lasts for much less time in the lifetime of a star than the proton-proton chain. We need lots of helium-4 in one place for a long time to make enough carbon, so this didn't happen in the big bang. Once we have carbon, helium-4 plus carbon can make oxygen-16 plus a gamma ray. Also, helium-4 can hit the carbon and make oxygen-15, where a neutron is released, or nitrogen-15, where a proton is released.
- ◆ This explains carbon and oxygen, but how did the in-between nuclei get made? The carbon and oxygen were made in a star and then expelled into the void at the end of the star's lifetime. High-energy protons—cosmic rays—hit some of those carbon and oxygen nuclei and broke them down into smaller nuclei. Some of the lithium and almost all of the beryllium and boron in the universe was made this way.

Bigger stars are bluer and more luminous; smaller stars are redder and less luminous.

- ◆ When a star exhausts its helium, then it gravitationally shrinks and becomes hotter until it finds a new power source. If the star is big enough, which means more than 8 times the mass of the Sun, then carbon burning begins in the core. For this process, we need a temperature of more than 1 billion Kelvin, and it lasts for only about 600 years. Two carbon nuclei come together to make an excited state of magnesium-24, which then decays—to neon-20 plus an alpha particle, or to sodium-23 plus a proton, or to magnesium-23 plus a neutron. It's an endothermic reaction, but it makes neutrons.
- ◆ When the star exhausts its carbon, the core now contains neon, oxygen, and magnesium. Again, it has lost its power source, so it gravitationally shrinks and gets hotter until it finds a new power source. If the star is big enough, then neon burning in the core starts. The temperature needs to be much more than 1 billion Kelvin. Neon-20 plus helium makes magnesium-24, and this process keeps going.
- ◆ Oxygen burning requires a higher temperature because it's more stable. It's a closed shell, so it needs a higher temperature to fuse.

How long does it take for a star to go from proton-proton fusion to silicon burning? For a 25-solar-mass star (it needs to be heavy to progress through all of the stages):

BURNS	PRODUCES	CORE TEMPERATURE	TIME
H	He	$6 \times 10^7$	$7 \times 10^6$ years
He	C, O	$2 \times 10^8$	$5 \times 10^5$ years
C	O, Ne, Mg	$9 \times 10^8$	600 years
Ne	O, Mg, Si	$1.7 \times 10^9$	0.5 years
O	Si, S	$2.3 \times 10^9$	6 days
Si	Fe	$4 \times 10^9$	1 day

- ◆ Silicon burning involves repeated fusion with helium to make heavier and heavier nuclei. And in the process, it makes all of the nuclei from hydrogen up through iron and nickel.

## Neutron Stars and Supernovas

- ◆ What will happen to our Sun after proton burning? This process exhausts the protons in the core, which becomes denser and hotter. Proton burning continues in the shell, but the envelope of the star expands to about the radius of the Earth and cools. The star leaves the main sequence and becomes a red giant. Our Sun is small, so it lives longer; it will stay a red giant for about a billion years. When the core becomes hot enough, there is **helium burning** in the core and hydrogen burning in the shell, and carbon accumulates in the core of the star.
- ◆ How will our Sun end? Our Sun is not big enough to burn the carbon, so the inert carbon core won't fuse. The core will continue to contract. The radius of the star will keep growing, and it will become a red supergiant. Some of the neutrons made in the star can be absorbed to slowly make heavier elements, in what is called s-process nucleosynthesis. But there isn't enough mass to start carbon burning. The core will become a white dwarf. The envelope will be expelled to become a planetary nebula, although the material won't disperse widely.
- ◆ A really big star, with a mass of more than 10 times the mass of the Sun, ends up with an iron core and lots of burning and inert shells. Iron can't fuse and release energy, so nothing heavier than iron can be made in normal stars. There is an energy crisis—it makes more and more iron. The core is inert; it's not producing power. The inert core contracts, and the temperature increases. The energy from the gravitational collapse increases the temperature.

- ◆ When the core temperature gets high enough, the iron in the central core is broken down into alpha particles, which are then broken down into their constituent protons and neutrons. Only the very central iron in the core is destroyed. It absorbs energy, cools the core, contracts faster, and heats up more.
- ◆ Then, because it's so dense, protons and electrons combine to make neutrons plus neutrinos. This is called neutronization. It's driven by the Pauli exclusion principle and explained by the Fermi gas model. The protons absorb the electrons, and the electron pressure is reduced. It speeds the core collapse. On the chart of nuclides, the nuclei move dramatically down and to the right, and we end up with a neutron star.
- ◆ The core then collapses very rapidly, at 0.2 times the speed of light. But the neutrons obey the Pauli exclusion principle. The core has a maximum density for the neutrons, which is about 3 times the nuclear density. If the core mass is too high, it's going to make a black hole, and there won't be a supernova. But if the core mass is not too high, then the core forms a hot neutron star with a temperature of about 100 billion Kelvin.
- ◆ The core hits that neutron-star surface and bounces back, making a shockwave through the envelope. Explosive nucleosynthesis occurs in the outside layers as the shockwave passes through. Lots of neutrons absorb on nuclei to make new nuclei. This is r-process nucleosynthesis. There is some beta decay that converts some of the neutrons to protons, but it's very rapid, and lots of very-short-lived nuclei are involved. Heavy elements are made and ejected, but the shockwave of the star stalls quickly.
- ◆ High temperatures lead to lots of particle-antiparticle production. Normal particles (electrons and antielectrons) reinteract and annihilate. But neutrino-antineutrino pairs can escape. They carry away about

10% of the rest mass; 99% of the energy in a supernova is released as neutrinos. The pressure from these neutrinos is what drives the explosion. Without neutrinos, the supernova can't explode—even though neutrinos interact through the weak nuclear force. The outer layers are violently ejected, and we end up with a core-collapse supernova.

A core-collapse supernova releases  $2 \times 10^{47}$  joules of energy. It's as bright as a galaxy— $10^{10}$  times the luminosity of the Sun—for a few days. But this is still much less than the energy given off in neutrinos.

- ◆ The core collapse turns the electrons and protons in iron into neutrons. The gravitational potential energy of the core collapse makes the explosion energy, which creates nuclei much heavier than iron. The evidence of this is we can model the process, tested by looking at the light curve and spectra of the supernova and the detection of neutrinos from supernova 1987A, which was detected in 1987 in the Large Magellanic Cloud.
- ◆ After a supernova, what's left is a neutron-star core. This is the biggest nucleus of all, with between 1 and 3 times the mass of the Sun. While the core of a neutron star is made almost entirely of neutrons, there are lots of heavy nuclei on the neutron-star surface, where the pressure is much less.
- ◆ How could some of those heavy nuclei escape to become the Earth's heavy elements? We need the inspiral and merger of a binary neutron-star system, which is 2 neutron stars orbiting around each other. Tidal forces can rip material from the surface of the smaller neutron star and eject it into the galaxy. Or gravitational energy can make neutrinos, and the pressure from the neutrinos can knock material off of the surface.

## Supplements

### READINGS

American Association of Variable Star Observers, “Supernova 1987A.”

Drake, “In a First, Gravitational Waves Linked to Neutron Star Crash.”

Ellis and Schram, “Could a Nearby Supernova Explosion Have Caused a Mass Extinction?”

Fields, “When Stars Attack!”

Henley and Garcia, *Subatomic Physics*, sections 19.1, 19.2, and 19.4.

LeBlanc, *An Introduction to Stellar Astrophysics*, sections 6.6–6.14.

Mackintosh, *Nucleus*, chaps. 9–10.

White, “Big Bang Nucleosynthesis.”

———, “Origin of the Light Elements.”

### QUESTIONS

- 1 Where does the energy come from to make all of the elements heavier than helium?
- 2 How do we know that some of the heavy elements are made in neutron-star collisions?

## ANSWERS

- 1 The energy to make the elements from helium to iron comes from the curve of binding energy. As lighter elements fuse to form heavier elements, energy is released. The energy to make the heavier elements comes from gravitational energy, either from the collapse of an ultraheavy star after it runs out of fuel or from the collision of 2 neutron stars. As the ultraheavy star collapses, its layers fall inward and gain energy. Part of this energy goes into fusing nuclei into heavier elements than iron, which are then distributed into interstellar space as the star becomes a supernova. Similarly, when neutron stars collide, we can think of it as one falling into the other one, gaining a lot of energy. While the interior of the neutron star is almost entirely neutrons, there are a lot of normal nuclei on its surface. Some of the energy gained from falling together makes heavier elements and causes material from the neutron stars to be ejected.
- 2 Prior to 2017, we relied on computer models of supernovas and neutron-star collisions, which told us that supernovas could not produce all the nuclei we see in the correct abundances. In 2017, scientists saw the gravitational waves from 2 neutron stars falling into each other. When they focused optical telescopes at that location, they saw absorption lines in the light corresponding to heavy elements such as gold. This was the first direct evidence that heavy elements were made in neutron-star collisions.



# 15

## SPLITTING THE NUCLEUS

**N**UCLEAR FISSION is the process whereby a nucleus splits into 2 smaller nuclei. This is very rare in nature. It happens when an appropriate nucleus absorbs a neutron. Only a few very large, even-numbered elements fission. Uranium is the only element with a naturally occurring isotope that can be fissioned. Uranium is relatively abundant. It's heavy enough to fission but stable enough to still exist. It's in the middle of the first so-called island of stability on the chart of nuclides [PAGE 274]. There are more protons, so there is more electrical repulsion, which makes it less stable. ◆

## Fissioning Uranium

- ◆ There are several isotopes of uranium. The most common one is uranium-238, with 92 protons and 146 neutrons. It has a half-life of 4.5 billion years, about the age of the Earth. Uranium-235, with the same number of protons but 143 neutrons, has a half-life of 0.7 billion years. Uranium-234, with 92 protons but only 142 neutrons, has a half-life of 0.25 million years, so there is no uranium-234 left over from when the Earth was formed.
- ◆ Uranium-238 has the same half-life as the Earth, so about  $\frac{1}{2}$  of the uranium-238 nuclei have decayed since the Earth was formed. Uranium-235 has a half-life that is 7 times less than the age of the Earth, so all but  $\frac{1}{128}$  of the uranium-235 nuclei have decayed.
- ◆ We expect the relative abundance of uranium-235 to be about 1.5%, but the actual abundance is 0.7%. We assume that uranium-235 and uranium-238 were created in equal amounts in a supernova and then formed relatively quickly, within about a billion years into our planet.
- ◆ There is a long decay chain for uranium.
  - Uranium-238 alpha-decays to thorium-234, with a half-life of 5 billion years. This decays very quickly by beta decay to protactinium-234. Then, it beta-decays again to uranium-234, giving off an electron and an antineutrino, in about a minute. Then, it decays to thorium-230 by alpha decay, to radium-226 by alpha

James Chadwick discovered the neutron in 1932, after which scientists looked to see what they could do with it.

Just 2 years later, Enrico Fermi discovered neutron-induced radioactivity, which earned him the 1938 Nobel Prize in Physics.

Otto Hahn and Fritz Strassman discovered uranium fission in 1939, which earned Hahn the Nobel Prize in Chemistry in 1944.

decay, to radon-222 by alpha decay, etc. It ends up at lead-206, with 82 protons and 206 nucleons, having given off 8 alpha particles, 6 electrons, 6 antineutrinos, and about 50 million electron volts of energy.

- The uranium-235 decay chain is very similar. It also ends up at lead, but it ends up at lead-207, having given off 7 alpha particles, 4 electrons, 4 antineutrinos, and also about 50 million electron volts of energy.
- ♦ Making uranium-235 fission instead of just decaying lets us liberate a lot more energy without waiting for 700 million years. We do this by hitting uranium-235 with a neutron. It absorbs the neutron and becomes uranium-236. This makes the charged nuclear droplet oscillate, just like in the liquid-drop model. If the oscillations get too big, then electrical repulsion makes it fission into smaller nuclei. It ends up in 2 big pieces—called **fission fragments**—plus 2 or 3 neutrons. Those fission fragments carry away 170 million electron volts of kinetic energy. Then there are neutrons and gamma rays.
- ♦ The reason that uranium-235 fissions but not uranium-238 is because uranium-235 has an even number of protons and an odd number of neutrons. When uranium-235 absorbs a neutron, it becomes uranium-236, with an even number of neutrons and an even number of protons. That even-even uranium-236 is more tightly bound than uranium-235, and the binding energy difference goes into the excitation energy. The excitation energy for uranium-235 is 6.5 million electron volts, which is enough to make it fission.
- ♦ When uranium-238 absorbs a neutron, it becomes uranium-239, which is even-odd and is less tightly bound per nucleon than uranium-238. The excitation energy of uranium-239 is only 4.8 million electron

Even uranium-235 only spontaneously fissions  $10^{-10}$  of the time.

volts, which is not quite enough to fission uranium-238. If we hit it with a higher-energy neutron (with more than 1 million electron volts), that will make uranium-238 fission.

- ◆ The energy released by fission comes from the curve of binding energy. Uranium has 7.6 million electron volts per nucleon of binding energy. But the fragments with smaller mass have more binding energy per nucleon—8.5 million electron volts. That means there is a difference of about 1 million electron volts per nucleon. Because uranium has about 200 nucleons, about 200 million electron volts will be released.
- ◆ Where does this fission energy go?
  - 170 MeV goes to the fission fragments.
  - 5 MeV goes to the neutrons.
  - 7 MeV goes to the gamma rays.
  - 27 MeV comes from delayed radioactivity. (Energy from the decays of the fission fragments is split up among the beta particles, with 8 MeV; the neutrinos, with 12 MeV; and the gamma rays, with 7 MeV).
- ◆ Which nuclei does uranium-235 fission into? There are many possibilities, but it typically fissions into 2 nuclei that don't have equal mass; one is a bit heavier and the other is a bit lighter. The fission fragments are statistically distributed, with the lighter mass fragments typically between 90 and 100 nucleons and the heavier mass fragments typically between 130 and 150 nucleons.
- ◆ Why are the decay products so radioactive? They have too many neutrons. Heavier nuclei need more neutrons to reduce the effects of the proton-proton repulsion. Fission makes lighter fragments with too many neutrons for their mass.

- ◆ How do we achieve a self-sustaining **chain reaction**? A neutron plus uranium-235 makes fission fragments plus 2 or 3 more neutrons. If exactly 1 of those 2 or 3 neutrons goes on to fission another uranium-235 nucleus, then it's **critical**, and fission continues at exactly the same rate.
- ◆ But if less than 1 neutron goes on to fission another uranium-235 nucleus, then it's **subcritical**, and the fission rate will steadily decrease. If more than 1 neutron goes on to fission a uranium-235 in the next generation, then it's super critical, and the fission rate increases. You might get an explosion. The number we refer to here is the neutron multiplication factor.
- ◆ A few things can happen to those extra neutrons: They can be absorbed by a uranium-238 nucleus, be absorbed by a uranium-235 nucleus without causing it to fission and instead emit a gamma ray, or can escape entirely if there is not enough uranium.

## Enriching Uranium

- ◆ How can we increase the neutron multiplication factor? We can have more uranium so that the neutron is less likely to escape. We can make the uranium more enriched so that the neutron is more likely to hit a uranium-235 nucleus than a uranium-238 nucleus. We can reduce the neutron energy (**moderate** the neutrons). This greatly increases the uranium-235 fission cross section and decreases the uranium-235 nonfission cross section, or the absorption cross section. Then, we can remove the other materials that can absorb neutrons.
- ◆ How do we enrich uranium? Chemical methods don't work. Uranium-235 and uranium-238 react almost identically, so we have to use physical methods that exploit the small mass difference between them (about 1%). This is very difficult.

- ◆ What enrichment levels do we need? We're starting with 0.7% uranium-235. For fuel, we need it enriched to between 3% and 5%. For bombs, we need it enriched to 90%. Low-enriched uranium means that the enrichment level is less than 20%, meaning that it's less than 20% uranium-235 and the rest is uranium-238. High-enriched uranium is anything above that. We'll use the same process to make low-enriched uranium or high-enriched uranium, but just with a different arrangement. It's much easier to enrich uranium if we start with 20% to get up to 90% than if we start at 0.7% to go to 20%.
- ◆ There are a number of uranium separation techniques, including thermal diffusion, gaseous diffusion, electromagnetic (where you use a kind of mass spectrometer), centrifuges, and lasers. The Manhattan Project used the first 3 techniques together to achieve more than 82% uranium-235 enrichment for the Little Boy gun-type nuclear bomb.
- ◆ For these techniques, we need the uranium to be able to move freely, which means that we need it in the form of a gas. There is only 1 molecule that is gaseous at even close to room temperature: uranium hexafluoride. It's solid at room temperature and pressure but boils at 57° Celsius (134° Fahrenheit), so above that temperature, it's a gas. Fluorine only has 1 stable isotope, and this makes separations simpler because any difference in mass between 2 molecules of uranium hexafluoride is due to the uranium and not to the fluorine.
- ◆ How do we separate uranium electromagnetically? It's a variant of a mass spectrometer that is optimized for throughput rather than for precision. In a typical mass spectrometer, we want to measure masses precisely, but here we want to separate 2 molecules with 2 different masses.
- ◆ We ionize uranium hexafluoride gas and accelerate the molecules through a potential difference so that they have the same amount of kinetic energy. Then, we pass them through a magnetic field. The radius of curvature in that magnetic field is mass times velocity, divided

by charge times magnetic field:  $R = mv/qB$ . Therefore, a 1% difference in mass, if they have the same velocity, gives us a 1% difference in the radius of curvature. This means that the uranium-235 will be bent in a smaller circle than the uranium-238, and we can use that to separate the uranium-235 and the uranium-238.

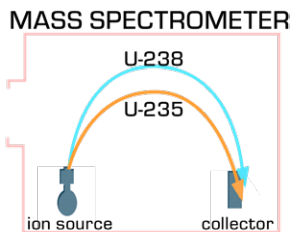

- ◆ In addition to electromagnetic separation, there is gaseous diffusion, in which we apply pressure to force the uranium hexafluoride gas through a porous membrane. All of the uranium hexafluoride molecules have about the same average kinetic energy, which is  $\frac{1}{2}mv^2$ . If the mass is smaller, the velocity is bigger. There is about a 0.5% change in the average velocity. That means that the uranium-235 hexafluoride diffuses slightly faster than the uranium-238 hexafluoride, which means that the uranium hexafluoride that passes through the tiny holes in the membrane is slightly enriched in uranium-235, while the gas left behind is slightly depleted. We need many stages of this gaseous diffusion to get decent enrichment.
- ◆ Centrifuges spin very rapidly. Think of a cylinder spinning on its axis very rapidly. The acceleration experienced by a particle on the outside of that cylinder is the centripetal acceleration, forcing it inward. Centripetal acceleration is the square of the rotational speed times the radius:  $\omega^2r$ . This acceleration provides a huge force.
- ◆ The centrifuge fights against the thermal motion of the particles. The thermal motion randomizes the material. The centrifuge makes heavier material move to the outside. We need to spin a big centrifuge as fast as possible to improve the separation. The maximum speed will

Centrifuges were invented in 1934 by Jesse Beams at the University of Virginia to separate chlorine isotopes.

be about 500 meters per second, or 1000 miles per hour. So, we need really strong materials and really good bearings.

- ◆ To optimize centrifuges, we heat the bottom to generate a flow of gas up the inner wall and down the outer wall. We increase the height of the centrifuge to take advantage of this. The lighter material—the uranium-235 hexafluoride—will collect at the inside and the top. The heavier material will collect at the outside and the bottom.

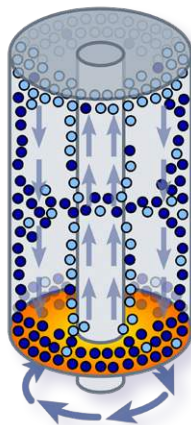

- ◆ When we're centrifuging uranium, we feed in the uranium hexafluoride gas continuously. There are 2 exhaust pipes: We take the enriched gas from the center and the top to go to the next stage, and we take the depleted gas that has less uranium-235 from the outside and the bottom to go to the previous stage.
- ◆ One centrifuge can't do it all. We need centrifuges in parallel and in stages. If we want to enrich uranium for a reactor, we need lots of centrifuges in parallel with just a few stages. If we want to enrich uranium for bombs, we need lots of stages and not as many in parallel.

Depleted uranium is very dense (70% denser than lead), so it is used for armor-piercing projectiles, counterweights, and radiation shielding.

- ◆ Depleted uranium is a little less radioactive than natural uranium, because uranium-238 has a half-life of about 4.5 billion years and uranium-235 has a half-life of about 0.7 billion years, which is 6 times shorter, so it's 6 times more radioactive. We've reduced the uranium-235 percentage from 0.7% to 0.3%, so we've reduced the overall radioactivity of the uranium by a few percent.

## Supplements

### READINGS

Bodansky, *Nuclear Energy*, chaps. 5 and 6.

GlobalSecurity.org, “Uranium Enrichment Techniques.”

Lilley, *Nuclear Physics*, sections 10.1–10.3.

PhET Interactive Simulations, “Nuclear Fission.”

Rhodes, *The Making of the Atomic Bomb*.

US Nuclear Regulatory Commission, “Uranium Enrichment.”

### QUESTIONS

- 1 If the half-life of uranium-235 was doubled to 1.4 billion years, how would that affect the relative abundance of uranium-235 in natural uranium?
- 2 What is the most common form of radiation from the daughter nuclei from uranium fission?
- 3 Why are we so concerned with nonnuclear nations enriching uranium to use in power plants?

### ANSWERS

- 1 Doubling the half-life would increase the abundance of uranium-235 by more than a factor of 10. If uranium-235 had twice the half-life (1.4 billion years instead of 0.7), then there would have been only 3.5 half-lives instead of 7 since the Earth was formed. After 7 half-lives, only  $\frac{1}{128}$  of the original uranium-235 is left, which is less than 1%. However, after only 3.5 half-lives, 10% of the original uranium-235 is left. Thus, instead of being only 0.7% of natural uranium, if the half-life were twice as long, uranium-235 would be 10% of natural uranium.

- 2 Uranium has about 1.5 neutrons for each proton. The daughter nuclei also have about 1.5 neutrons for each proton. However, stable nuclei in that mass range have only about  $\frac{1}{3}$  more neutrons than protons. Therefore, the daughter nuclei have too many neutrons and need to convert neutrons to protons. They do this by beta-minus decay.
- 3 We are concerned because the same technology used to enrich uranium from its natural abundance of 0.7% to the 4% needed for power plants can enrich the uranium further to the 90% needed for weapons. It takes much less effort to enrich uranium from power plant grade to bomb grade than it does to enrich it from natural abundance to power plant grade.



# 16

## NUCLEAR WEAPONS WERE NEVER “ATOMIC” BOMBS

The term “**atomic bomb**” was first used by H. G. Wells in his 1914 book *The World Set Free*. This launched an idea that is wildly inaccurate. Conventional explosives use chemical reactions and should be called molecular bombs because they rearrange molecules. Atomic bombs should be called nuclear bombs because they rearrange nuclei. But the Manhattan Project scientists called their weapons “the gadget” or “atomic bombs,” layers of misdirection to conceal what they were doing. ◆

## Nuclear Bombs and Chain Reactions

- ◆ We can make nuclear bombs from uranium-235. We want to use it very highly enriched—preferably 90% enriched or better—because uranium-238 absorbs some of the critical neutrons that we want to go on to fission uranium-235 instead. Lower-enrichment bombs are possible, but they need a lot more uranium.
- ◆ We can also make nuclear bombs from plutonium. Plutonium is a reactor by-product from uranium-238. When uranium-235 absorbs a neutron, most of the time it fissions. Uranium-238, instead, can absorb neutrons. When uranium-238 absorbs a neutron, it becomes uranium-239 and gives off a gamma ray. The uranium-239 then beta-decays to neptunium-239, giving off an electron and a neutrino. Neptunium-239 then beta-decays to plutonium-239, again giving off an electron and a neutrino.
- ◆ Plutonium-239 is a desired isotope, but it can absorb neutrons and become plutonium-240, so you need to withdraw the fuel before too much plutonium-239 can become plutonium-240. But plutonium-240 fissions spontaneously, which could cause the bomb to preignite and fizzle. So, weapons-grade plutonium has very little plutonium-240; it's almost all plutonium-239. Reactor-grade plutonium has more plutonium-240 and relatively less plutonium-239.

---

Only 1 kilogram of chemical explosives can liberate 4 million joules of energy. This gives us the definition of a kiloton: 1000 tons of chemical explosive, or  $4 \times 10^{12}$  joules.

Through the process of fission, 1 kilogram of uranium-235 releases about  $10^{14}$  joules of energy, which is 30 million times more energy than is released from 1 kilogram of TNT.

- ◆ The Chernobyl reactors—and similar reactors in the United States in Hanford, Washington—were designed to remove and replace fuel rods easily while the reactor is running. They make weapons-grade plutonium by removing the fuel rods often, extracting the plutonium-239 before it can become plutonium-240, and then putting them back. Reactors like this can make 1000 kilograms of plutonium per year from a gigawatt of electricity.
- ◆ Most power reactors, called **light-water reactors**, are of a different design and need to be shut down for refueling, so fuel rods are left in for 1 to 3 years before being replaced. This makes reactor-grade plutonium. It makes about 300 kilograms per year—enough for about 30 bombs. They make less plutonium than the Chernobyl reactors because a lot of the plutonium is fissioned in the power plant to make more energy. Another way to make plutonium is to place uranium-238 targets near a reactor core (and replace them often, without disturbing the operation of the reactor).
- ◆ How much fissionable material is needed for a **critical mass**? We need most of the neutrons to interact to fission the uranium or plutonium. This means that we need a sphere of material whose radius is about the same length as the neutron interaction length.
- ◆ Fast neutrons—the neutrons emitted by fission that are typically on the order of millions of electron volts—have a cross section of about 1 barn before they're moderated and slowed down. This cross section is much less than the thermal neutrons, which have been slowed down to room temperature. The fast neutrons have a mean free path and interaction length of about 17 centimeters in uranium and 12 centimeters in plutonium. So, plutonium has a higher fission cross section.
- ◆ We can use a reflector placed outside of the uranium or the plutonium to reflect some of the neutrons back and decrease the amount of material that we need. For uranium, if there is no reflector, we need a sphere radius of 9 centimeters, so the diameter is about 18 centimeters,

or 8 inches. If we have a reflector, then the radius of the sphere is 6 centimeters and the diameter is 12 centimeters, or 4 inches, so we need between 13 and 25 kilograms of uranium. For plutonium, if there is no reflector, then the sphere radius is only 5 centimeters, or 2 inches. If we use a reflector, then the radius is 4 centimeters, which means that we only need 5 or 10 kilograms of plutonium.

- ◆ To trigger the chain reaction, we jump-start it with a lot of neutrons. We use an alpha emitter, such as americium, that gives off alpha particles and a beryllium target, with a very thin wall between the 2 to stop the alphas. When we want to start the chain reaction, we break the wall. The alpha particles can hit the beryllium and knock out neutrons.
- ◆ There are a few ways to make a bomb. The simplest way is with a gun-type bomb, where we shoot one subcritical mass of uranium onto another subcritical mass to make a critical mass.
- ◆ With the Little Boy bomb, an 86-pound hollow cylinder of uranium was shot at a 60-pound spike of uranium. The uranium was about 80% enriched, was in a 6-foot-long barrel, and was hit at 300 meters per second (about 600 miles an hour). It went critical at about 10 inches away, or 0.3 meters. It needed to have very few spontaneous fissions in the time it took those 2 pieces to move that last 0.3 meters—which, traveling at 300 meters for 1 second, was about a millisecond—to avoid premature detonation and fizzle. They didn't test this design; they were sure that it would work. This design would not work with plutonium because too much plutonium spontaneously fissions.



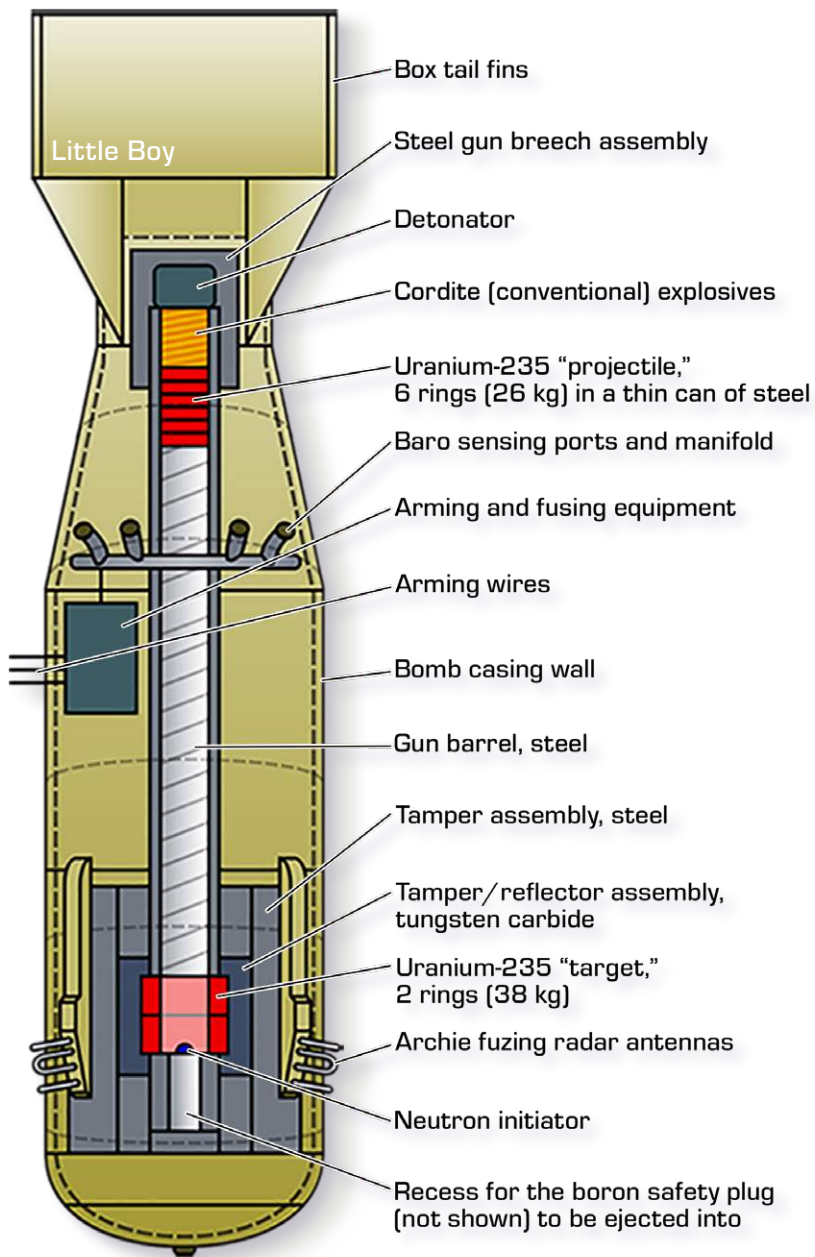

- ◆ The other kind of bomb is an implosion bomb, where we compress fuel using a shockwave that travels at 5000 meters per second. We need a very symmetric shockwave, which means that we need to use specially shaped high-explosive lenses and perfect timing. The compression gives it a higher density, which decreases the neutron interaction length and the critical mass that is needed. By compressing a subcritical mass of plutonium or uranium, it becomes critical. We need less plutonium or less uranium. But we need to make sure that the ignition starts when it's fully compressed and not an instant before so that there is very little spontaneous fission.
- ◆ This was the design of the Fat Man bomb that was dropped in Nagasaki with an energy release of 21,000 tons of TNT. This implosion-type plutonium bomb was much more complicated than the gun-type uranium bomb, and they needed to test it to make sure it would work. This was the famous Trinity test, when the first nuclear bomb was detonated.

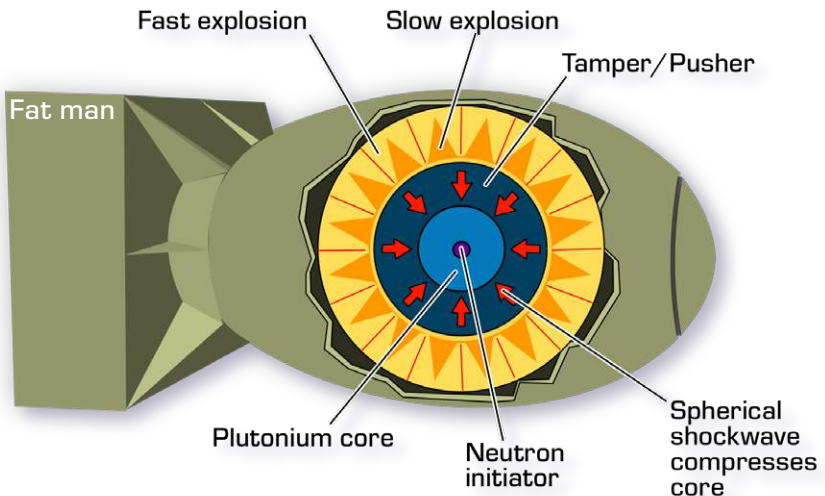

## Fat Man

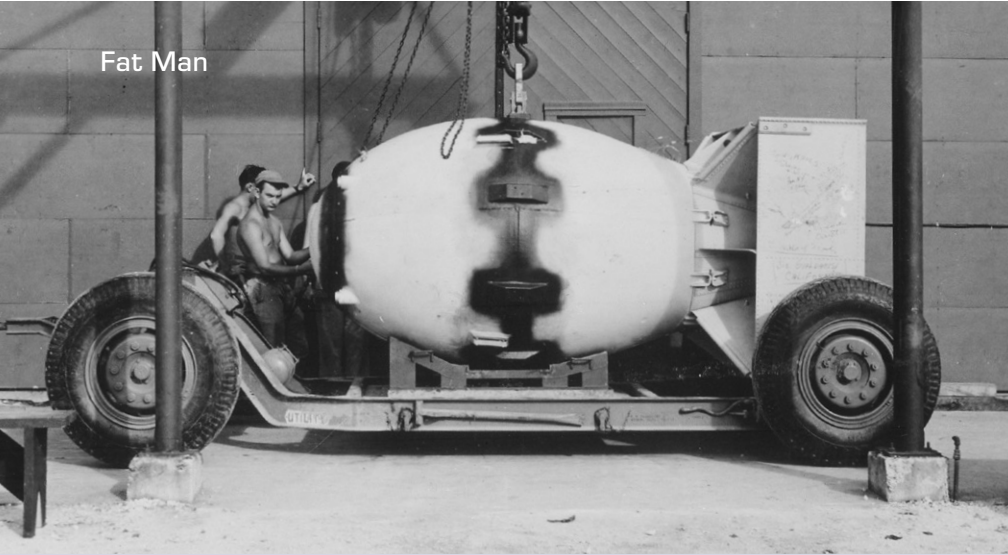

- ◆ The Little Boy, like the Fat Man, used a chain reaction to release as much nuclear energy as possible. With a chain reaction, we need to release all of the energy before the bomb material can disassemble. We have to use fast neutrons to do the fissioning because they have a smaller cross section; there is no time for the neutrons to bounce around a moderator and slow down and thermalize. We want to maximize the neutron multiplication factor ( $k$ ) because the bigger it is, fewer generations are needed to fission all the nuclei. Reactors want a  $k$  of exactly 1 so that they keep running at constant power.
- ◆ Let's think about the reaction in generations. In one generation, some nuclei fission and release neutrons. In the next generation, there are  $k$  times more nuclear fissions. The time of a generation is the neutron interaction length divided by the velocity.

Enrico Fermi, one of the great physicists of the 20<sup>th</sup> century, built the first atomic pile, which had the first sustained nuclear chain reaction.

- ◆ A 1-million-electron-volt neutron has a speed of  $1.4 \times 10^9$ , which is about 3% of the speed of light. Its interaction length is about 10 centimeters, so the time it takes for it to interact is about  $10^{-8}$  seconds, or 10 nanoseconds. That length of time was called a shake by the Manhattan Project.
- ◆ It takes 80 generations to fission 1 kilogram of uranium. The time required to do this is 80 shakes, or about 1 microsecond (1 millionth of a second). Half of the nuclei fission in the last generation.
- ◆ The problem is that the warhead starts to disassemble and spread out when about 1 in a million of the nuclei have fissioned. Enough energy is released so that the fuel starts expanding. If it predetonates, we get a fizzle yield of only about 1000 tons of TNT. We need to keep the bomb together for another 20 shakes, which is a quarter of a microsecond, to let the rest of the uranium fission.

## Controlling the Fissile Material

- ◆ Building bombs is the easy part; controlling the fissile material is the difficult part. Uranium needs to be enriched, which is expensive and difficult. But this is the path that Iran is taking with its thousands upon thousands of centrifuges. Bomb-grade uranium (90% uranium-235) can be denatured by mixing it with natural uranium. We've reduced our Cold War stockpiles of highly enriched uranium this way.
- ◆ With plutonium, a reactor needs to be operated and the plutonium has to be chemically extracted from the very radioactive spent fuel. This is the path that North Korea has followed. In some ways, this is easier than enrichment, but you have to remove the fuel from the reactor very often.

- ◆ This is done by **reprocessing** plants, which make plutonium much more available. This is one of the reasons why the United States stopped reprocessing fuel in the late 1970s. Plutonium can't be denatured, which means that Cold War stockpiles of plutonium need to be guarded.
- ◆ To make a bigger bang, we use a fusion-boosted bomb, which involves adding deuterium and tritium in the center of the bomb. If we can get the deuterium and tritium to fuse, it will make helium-4 plus a neutron and release 14 million electron volts. The extra neutrons boost the fission yield, and we get more energy from the extra fissions (200 MeV of energy) than we do from the fusion (14 MeV of energy).
- ◆ Deuterium and tritium are gasses, which means they are not very dense, so we typically add lithium deuteride, which is lithium hydride, but instead of being made with hydrogen, it is made with heavy hydrogen (deuterium), which is a solid. And the lithium deuteride makes the tritium: When a neutron hits the lithium, it makes a helium-4 and a tritium.
- ◆ If we want even more energy released, then we make a **thermonuclear bomb**, where we start with a fusion-boosted fission bomb and then add a careful layering of lithium deuteride, plutonium, and reflectors. The fission bomb sets off the secondary, and the thermonuclear bomb actually gets a lot of its energy from nuclear fusion.
- ◆ How do we miniaturize nuclear warheads to fit in a missile? Fission or fusion-boosted warheads can be smaller than thermonuclear ones. They can be made of uranium or plutonium, but we need less plutonium for that critical mass, so we can make a smaller weapon from plutonium. Then, we need to

The biggest bomb ever set off—Tsar Bomba—was 50 million tons of TNT, which is more powerful than all of the explosives used in World War II.

optimize the shockwave to minimize the explosives needed to compress the plutonium or uranium.

- ◆ A Trident II ballistic missile submarine carries 24 missiles. Each missile carries up to eight 100- or 500-kiloton nuclear warheads that are inside their own reentry vehicles so that they can survive reentry from space.

A dirty bomb is not a nuclear explosion. It uses conventional explosives to disperse radioactive material, spread the radiation over a large area, and contaminate the ground.

## Supplements

### READINGS

Bodansky, *Nuclear Energy*, chap. 17.  
Dyson, *Project Orion*.  
Mahaffey, *Atomic Awakening*.  
Rhodes, *The Making of the Atomic Bomb*.

### QUESTIONS

- 1 Why is it easier to make a nuclear bomb from highly enriched uranium-235 than from plutonium?
- 2 Is it possible to make a nuclear reactor that does not produce plutonium?

## ANSWERS

- 1 Uranium-235 has a much lower spontaneous fission rate. In other words, many fewer uranium nuclei than plutonium nuclei fission on their own. The spontaneous fission rate of uranium-235 is about 1000 times less than that of plutonium-239. In the gun design used for the Little Boy uranium bomb, it took 1 entire millisecond (100,000 shakes) between the time when the 2 pieces of uranium in the bomb came close enough to form a critical mass and the time the bomb was ignited. There was less than 1 chance in 1000 that a uranium nucleus would spontaneously fission during that time, igniting the bomb prematurely and making it fizzle.
- 2 No, unless there is no uranium-238 in the reactor fuel. All the reactor fuel used today is about 96% uranium-238 plus 4% uranium-235. Some of the neutrons released by uranium-235 fission are absorbed by uranium-238 and make plutonium-239. (**Thorium reactors**, which would not produce plutonium, are discussed in lecture 19.)



## HARNESSING NUCLEAR CHAIN REACTIONS

**D**id you know that nuclear power plants boil water to turn a turbine to move wires near magnets to generate electricity, just like coal-fired power plants do? The uranium needed to fuel a nuclear power plant for a year could fit under your dining room table, but the coal needed to generate the same amount of electricity for a year would fill a 150-car coal train every day for an entire year. Nuclear fission provides reliable, carbon-free electricity to millions of homes and powers submarines and aircraft carriers. ◆

At 5% enrichment, 20 tons of uranium—which takes up about 1 cubic meter of space—is needed to fuel a power plant that produces 1 gigawatt of electricity for 1 year.

## Fission Reactors

- ◆ Fissioning uranium-235 releases energy. Fission rearranges the nucleons in nuclei to release energy. (Chemical reactions, on the other hand, rearrange electrons in atoms to release energy.) The energy released is used to boil water to turn a turbine to turn a generator to generate electricity.
- ◆ We want a critical mass of uranium so that the fission keeps on going. When uranium fissions, it gives off about 2.5 neutrons. When plutonium fissions, it gives off 2.9 neutrons. We want only one of those neutrons to fission the next uranium or plutonium nucleus.
- ◆ Most neutrons are prompt, but about 0.65% are emitted later from radioactive decay. Those **delayed neutrons** are important for stable reactor operation.
- ◆ Neutrons come out in a broad energy range, from 0 to 8 million electron volts. High-energy neutrons have a much lower cross section to fission the uranium and are much more likely to be captured by uranium-235, not fission it. So, the cross section depends on the neutron energy. This means that the neutron interaction length depends on the neutron energy, because the bigger the cross section, the shorter the distance the neutron travels before it interacts.

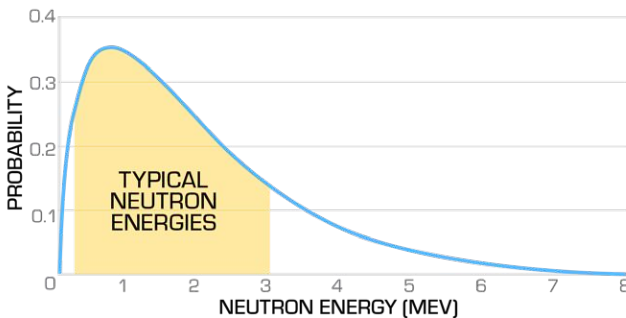

- ◆ Slower neutrons have a much bigger fission cross section and a much shorter interaction length, so we need to slow the neutrons down, or moderate them, through lots of elastic collisions with other nuclei.
- ◆ Which nuclei do we want to use? The closer in mass the 2 particles are in a collision, the more they share the energy in a collision. We want the neutrons to have elastic collisions and bounce off of light nuclei—such as protons, deuterons, carbon nuclei—so we want to moderate them.
- ◆ After lots of collisions, the neutrons thermalize, which means that they end up with the same average kinetic energy as the hydrogen, deuterium, or carbon atoms. They are at room temperature, which tells us that the average kinetic energy of each is about 0.025 of an electron volt.
- ◆ To keep the chain reaction going, at least 1 neutron from each fission has to first thermalize, which means dramatically decrease its energy; not escape the reactor; interact in the fuel (not in the moderator, or in the other elements); and fission the fuel, rather than being absorbed.
- ◆ We want the neutron multiplication factor ( $k$ ) to equal 1 for stable reactor operation. (We want only 1 neutron from each fission to go on to fission other nuclei.) This factor depends on the fuel enrichment, the moderator, and other material that might be in the reactor.
- ◆ How quickly do operators need to react when  $k$  gets bigger than 1? This depends on the mean neutron lifetime between the emission of the neutron and when that neutron goes on to fission the next uranium. For **prompt neutrons**, that lifetime is 0.1 milliseconds. But 0.65% of the neutrons come from delayed decay with a typical half-life of about 10 seconds. Delayed neutrons dramatically lengthen the multiplication time, giving us lots of time to react. We just have to make sure that  $k$  stays less than 1.006.

- ◆ The neutrons absorbed in the fuel can fission the uranium-235, be absorbed by the uranium-235 without fissioning to make uranium-236, or be absorbed by the uranium-238 to make uranium-239. Uranium-239 beta-decays fairly quickly to neptunium-239, and the neptunium-239 decays relatively quickly to plutonium-239, which is fissionable (usable in reactors or bombs).
- ◆ A typical light-water reactor will produce about  $\frac{1}{2}$  of a plutonium for each uranium-235 that is fissioned. The plutonium also fissions in the reactor, so it extends the fuel life of the reactor.
- ◆ How do we control the reaction rate? Typically, we insert or remove materials that have large thermal-neutron capture cross sections (if we can capture more neutrons, then fewer of them go on to fission more uranium—or maybe we want to capture fewer neutrons). We can use boron-10, with a cross section of 4000 borons and an abundance of about 20% of boron, so we don't have to enrich it. Or we can use cadmium-113, with a cross section of 20,000 borons and a reasonable abundance of 12%. To control the reaction rate, the **control rods** can be inserted further or removed.
- ◆ If we want to start with more enriched fuel, we can put burnable poisons, such as boron, in the fuel rods to absorb neutrons. Boron-10 absorbs neutrons to become boron-11, which no longer absorbs neutrons. Uranium-235 absorbs neutrons and fissions.
- ◆ If we start with more uranium-235 in the fuel rods, we'll also put in some boron-10. Over time, the uranium-235 level will decrease, making the reactor less reactive. The boron-10 level will also decrease, making the reactor more reactive. This keeps the total reactivity approximately constant and lets the reactor operate more stably.

## Human-Built Reactors

- ◆ There are generally 2 purposes for human-built reactors: to produce electrical power and to produce electrical power and generate plutonium. There are 2 main types of reactors: thermal-neutron (slow-neutron) reactors, which use a moderator to slow the neutrons down to thermal energies; and fast-neutron reactors, which don't use a moderator and are higher in energy.
- ◆ A conventional reactor needs fuel—uranium-235, usually in the form of uranium oxide, in pellets in fuel rods. A typical fuel rod is about 1 centimeter in diameter and 4 meters long and weighs about 10 pounds. The reactor also needs a moderator, either **light water**, **heavy water** (deuterium oxide), or carbon. It needs a coolant, which transfers the energy from the hot fuel to the electrical turbine and keeps the core from melting down. Typically, light water, heavy water, or (if carbon is a moderator) a gas (such as carbon dioxide or helium) is used. The reactor also needs control rods to control the reaction.
- ◆ To turn heat into electricity, we use the heat to boil water to turn a turbine to spin a generator. Then, we need a cold sink to dump the waste heat into. That cold sink can be a river, a lake, or an ocean, or we can use a cooling tower, which cools by evaporating a lot of water and has a shape that maximizes airflow. The thermodynamic efficiency is about  $\frac{1}{3}$ , which means that  $\frac{2}{3}$  of the energy has to be dumped into a cold sink. The same process of turning heat into electricity is used for coal, natural gas, and nuclear power.



Cooling Towers

## Today's Reactors

- ◆ In light-water (regular hydrogen, not deuterium) reactors, the water is both the moderator and the coolant. There are 2 general types of light-water reactors. In pressurized-water reactors, water is under high pressure so that it doesn't boil (higher pressure means a higher boiling point), and the primary cooling water transfer its heat to a secondary water system, which boils and turns a turbine. In boiling-water reactors, the primary water boils and uses the steam to turn a turbine, so it doesn't need a secondary water system.
- ◆ A pressurized **heavy-water reactor**, such as the CANDU plant in Canada, uses a heavy-water moderator (deuterium oxide) and a heavy-water primary coolant, so it can use unenriched uranium. The heavy water transfers its heat to a light (regular) water secondary system, which then boils and turns the turbine.
- ◆ A water-cooled graphite-moderated reactor is similar to Fermi's original reactor in that it is graphite-moderated, but now it is water-cooled. It can also run on natural uranium, so this is a Chernobyl-type reactor. It's built for power and for producing bomb-grade plutonium.
- ◆ The pressurized-water reactor—the most common reactor in use today—uses pressurized water (at 150 atmospheres and about 300° Celsius, or 600° Fahrenheit) as a coolant and a moderator in the **reactor vessel**. It's a closed loop, so the water doesn't escape. There is a reactor pressure vessel that is about 40 feet high, 15 feet in diameter, and 8 inches thick. The primary water system transfers its heat to a secondary water loop in the steam generator. It has a containment building with concrete and steel to contain everything inside of it.

Light-water reactors were originally developed for the US Navy under the guidance of Hyman Rickover.

The first nuclear reactors were placed on submarines.

## THE PRESSURIZED-WATER REACTOR (PWR)

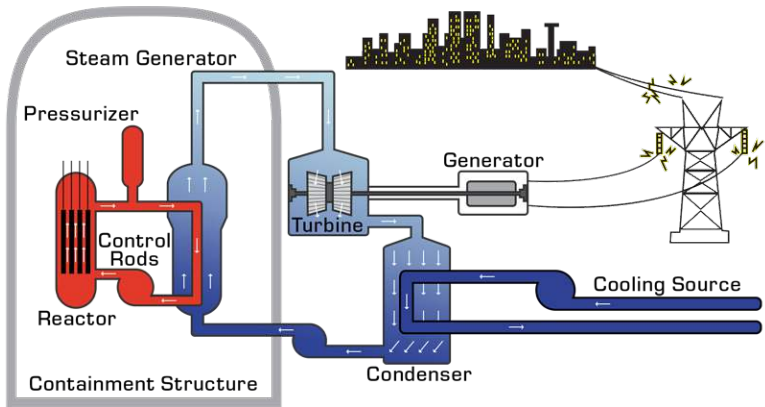

- ◆ The steam from the secondary water system turns a turbine, which turns a generator. A condenser condenses the steam to make the low-pressure side of the turbine. The cooling source for that condenser can be an ocean, a lake, a river, or a cooling tower.
- ◆ For fuel, a pressurized-water reactor uses uranium oxide pellets in 4-meter-long, 1-centimeter-diameter zirconium alloy (Zircaloy) fuel rods. There are about 50,000 fuel rods in the reactor core. The fuel rods remain in the core for about 3 years. They are typically refueled or replaced every year or 2. The plant has to be shut down for refueling.
- ◆ What makes a pressurized-water reactor safe? First, there are multiple levels of containment: Uranium oxide pellets retain most of the radionuclides. The pellets don't escape because they are enclosed in zirconium alloy fuel rods, which are enclosed in a pressure vessel and a closed primary coolant loop. And all of that is enclosed in a containment vessel.

- ◆ There are active controls, in the form of controller rods that can move in and out. There are also passive controls: The moderator is the coolant, so if there is any loss of coolant due to boiling or to a leak, then there is less moderator. Decreased moderation decreases the neutron multiplication factor and stops the chain reaction.

There are about 440 nuclear power plants around the globe, which generated 11% of the world's electricity in 2014. There is no carbon dioxide emission.

- In France, nuclear power is used to generate 75% of their electricity.
- In Japan, nuclear power is used to generate 30% of their electricity (but all of Japan's plants were idled after Fukushima).
- In the United States, nuclear power is used to generate about 20% of their electricity, using about 100 reactors.

## Supplements

### READINGS

Bodansky, *Nuclear Energy*, chaps. 6–8 and 14.

Cowan, “A Natural Fission Reactor.”

Lilley, *Nuclear Physics*, sections 10.5–10.6.

Mahaffey, *Atomic Awakening*.

Morrison, “Where Fiction Became Ancient Fact.”

“The Oklo Reactor,” *re-actions*.

World Nuclear Association, “Nuclear Power in the World Today.”

### QUESTIONS

- 1 If a power reactor uses reactor fuel that is enriched to 4% uranium-235, how could the reactor fission more than 4% of the nuclei in the fuel to release more energy?

- 2 Do reactor control rods containing cadmium get used up?
- 3 Can a reactor be made using unenriched uranium?
- 4 Do all nuclear reactors use the iconic cooling towers? Are cooling towers only used by nuclear reactors?

## ANSWERS

- 1 Some of the uranium-238 in the reactor core will absorb neutrons and end up (after 2 beta decays) as plutonium-239. Some of the plutonium-239 will be fissioned in the reactor.
- 2 Yes. When cadmium-113, with a neutron absorption cross section of 20,000 barns, absorbs a neutron, it becomes cadmium-114, with a much lower neutron absorption cross section. As more and more of the cadmium-113 nuclei absorb neutrons, the control rod becomes less and less useful.
- 3 Yes, but it needs to use carbon or heavy water for the moderator (because the hydrogen in regular water will absorb too many neutrons) and it needs to be very large so that fewer neutrons will escape the reactor. The very first nuclear pile used natural uranium.
- 4 No and no. Nuclear reactors use about 3 gigawatts of thermal power from uranium fission to produce about 1 gigawatt of electrical power. This means that they need to dump 2 gigawatts of thermal energy somewhere. Many reactors dump the waste heat into rivers, lakes, or oceans. Coal- and natural gas-fired power plants also only convert about  $\frac{1}{3}$  of their thermal energy into electrical energy and also need to dump the other  $\frac{2}{3}$ . Like nuclear power plants, coal- and natural gas-fired power plants also use rivers, lakes, oceans, or cooling towers.

# 18

## NUCLEAR ACCIDENTS AND LESSONS LEARNED

**N**uclear power plants are extraordinarily safe most of the time, but there have been a few dramatic accidents, including **Three Mile Island**, **Chernobyl**, and **Fukushima**. From these accidents, we have learned to make sure that the safety system is multilayered; accidents are caused by multiple mistakes aligning badly, so layers of a safety system should not have a common failure point. We also learned to make sure that the chain reaction stops. In addition, we learned to make sure that the cooling continues; we need long-term passive cooling, which requires a continuous supply of water. ◆

## Three Mile Island

- ◆ The biggest disaster that didn't kill anyone was in March of 1979 at Three Mile Island, which was a 900-megawatt electric pressurized-water reactor built by Babcock & Wilcox. It had only been running since 1978.
- ◆ At 4 o'clock in the morning, the secondary coolant water flow was interrupted. This was probably caused by system maintenance. There was an emergency shutdown of the reactor, and the control rods were inserted. This is called a scram. The chain reaction (fission) was stopped, and the emergency backup pumps were started.
- ◆ The problem was that the emergency backup pump valves were closed for maintenance. This was the key failure. The operators didn't notice this. The primary coolant—the water—heated up and turned to steam. A relief valve opened to vent the steam from the primary coolant. The relief valve stuck open, but the indicator for the valve in the control room showed that it was closed, so the valve stayed open for 2.5 hours. During this time, the coolant boiled off.

Core meltdowns are typically caused by a **loss-of-coolant accident**. A chain reaction stops in a pressurized-water reactor due to a loss of moderator, but residual power is still generated—200 megawatts of power immediately after, dropping to 16 megawatts after 1 day. If there is no coolant, the temperature of the core rises dramatically, and the fuel rods in the reactor core melt down, forming corium.

A core meltdown can ruin a multibillion-dollar reactor, but there is typically no explosion, no escape of core material, and no danger to the public unless a lot of radioactivity is released.



- ◆ There was a lot of confusion in the control room. There were more than 1000 dials, gauges, and indicators; 600 alarm panels; and hundreds of switches. A minor problem would cause alarms and blinking lights, and there could be 50 alarms at a time. The temperature of the fuel increased, and the fuel melted down.

- ◆ It was recommended that pregnant women and preschool children be evacuated, and another 130,000 people self-evacuated. They worried that there was a hydrogen bubble inside the reactor vessel that might explode. Fortunately, there wasn't enough oxygen in the reactor vessel for the hydrogen to react with, so there couldn't have been an explosion. But there was a lot of public concern.
- ◆ How bad was Three Mile Island? The core melted down, but the corium—the melted-down core materials—was contained in the reactor pressure vessel. The containment worked, and there was very little radiation release. The maximum dose to any of the workers at the power plant was about 4 rem, which is less than the annual safety limit of 5 rem. The maximum offsite dose was less than 0.1 rem, which is less than the annual safety limit for the general public.
- ◆ Only gases escaped the core. Iodine-131 bonded to the concrete of the containment building, so only about 15 curies out of 64 megacuries were released. Xenon-133 was released, but that had almost no biological effect; xenon is a noble gas, so it doesn't bond to anything, and it dispersed quickly.
- ◆ The maximum dose rate just outside the reactor vessel was about 1.2 rem per hour. The total collective dose would cause about 1 extra cancer (assuming the very conservative linear no-threshold hypothesis). We would expect about 300,000 natural cancer deaths out of 2 million people in the area, so which 1 was actually due to Three Mile Island?
- ◆ There were no measurable adverse health effects, but this disaster disrupted the lives of more than 100,000 people due to evacuations. It cost about a billion dollars to clean up and wrecked a 5-billion-dollar nuclear power plant.

---

## Is nuclear power too much trouble?

Comparatively:

- Oil can spill and has geostrategic risks.
- Coal is dangerous to mine and creates air pollution when burned.
- Hydropower dams rivers and floods scenic canyons, and dams can burst with catastrophic effect.
- Wind is intermittent and expensive, but it is getting cheaper. It already kills hundreds of thousands of birds yearly.
- Solar is intermittent and expensive, but it is getting cheaper. It uses a lot of land, with impact on ecosystems.

Most nonnuclear deaths are one at a time and do not make the news. Estimates of accidental and air pollution–related deaths in 2007 found that nuclear had been safer and cleaner than oil, coal, biomass, or gas. But 99% of those nonnuclear deaths are attributed to air pollution, and nuclear power does not emit carbon dioxide.

How do you want to generate our terawatts of electricity?

---

## Chernobyl

- ◆ The worst reactor accident was on April 26, 1986 at Chernobyl, which was not a Western light-water reactor. It was a graphite-moderated and water-cooled reactor, so there was water in vertical metal pipes passing through the core, and the water absorbed the heat and boiled.
- ◆ It was an RBMK-1000 reactor, generating 1000 megawatts of electricity. There were 4 operating at the Chernobyl site, and 2 more were under construction. Unit 4 had just been built in 1983, and units 1 and 3 continued operation until 1996 and 2000, respectively. They operated on natural uranium because they didn't need to enrich the uranium with a graphite moderator. This is similar to Fermi's original reactor, which he built in Chicago by piling up graphite and uranium.
- ◆ This reactor was optimized for plutonium production for bombs, which meant that the fuel rods could be swapped into and out of the reactor while it was running. This is similar to the reactors in the United States that were built to make plutonium. We want plutonium-239 with as little other plutonium isotopes as possible, which means that we want to remove the fuel rods and extract the plutonium after some plutonium-239 has been made, but before it can absorb another neutron and make plutonium-240.
- ◆ Chernobyl had some design issues. It was much bigger than the submarine-influenced light-water reactor designs in the United States and was too large for a convenient containment structure. The core was 46 feet in diameter and 23 feet high, and 12-foot-long fuel rods were inserted vertically.
- ◆ The moderation was mostly done by carbon. The cooling water could do a little moderation, but it mostly absorbed neutrons. If the amount of water decreased, then there was a little less moderation, which is negative feedback, and less neutron absorption, which is positive feedback. Chernobyl had net positive feedback—which is very bad.

- ◆ There was also a control rod design defect. The control rods were removed by lifting them upward. To keep the water from filling the control rod channel (and also from absorbing neutrons), a graphite displacer was attached. But there was about 1.25 meters, or 4 feet, of water at the bottom of the control rod channels. Inserting the control rod initially replaced the water with carbon, and that initially makes things worse. In addition, the rods moved much more slowly than needed—18 seconds to insert.

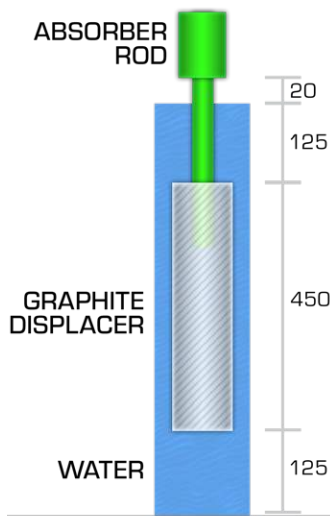

- ◆ The safety test went wrong. They planned to test the function of the pump during loss of power, so they reduced the power, but they overshot. The buildup of xenon (fuel poison) caused the operators to remove 205 out of 211 control rods. They ignored the unexpected conditions and continued the test.
- ◆ The test reduced steam flow to the turbine, which decreased the water flow in the reactor, which meant more boiling, less water, and more reactivity—positive feedback. This led to an increase of control rods, which made things worse, increasing the reactivity to prompt **supercritical**. This means that the timescale for the exponential increase of the reactivity was very short. If there was a sharp increase in power output, it might have hit 30 gigawatts. It's not entirely clear what happened next.
- ◆ Within about 20 seconds, there were 2 explosions. The first was a steam explosion, which exposed the reactor fuel to air. The second was either a chemical explosion between the reactor material and the air or runaway reactor criticality, which is like a very-low-yield nuclear bomb. These explosions started fires.

- ◆ The big tanks of water under the reactor turned to steam and exploded, blowing the 500-ton reactor cap off. Then, there was a hydrogen explosion and fire, and the core and radioactive debris—and the fission products in the core—were widely dispersed. Most of these are volatile nuclides.
- ◆ Firefighters weren't told what they were fighting. Water doesn't put out graphite fires. Eventually, they figured it out and dumped a lot of sand, lead, and boron, etc., from helicopters.
- ◆ No announcement was made. About 2 days later, in Sweden and Finland, radiation alarms started going off and the radiation alarm at a Swedish nuclear power plant went off because radioactive contamination was tracked in on a plant worker's shoes.
- ◆ There were about 50 tons of vaporized uranium. That wasn't a problem; the uranium is not significantly radioactive. But there was a plume of other material, including noble gases, such as krypton-85 and xenon-133; 48 megacuries of iodine-131 (which can damage the thyroid gland), with a half-life of 8 days; 1.5 megacuries of cesium-134, with a 2-year half-life; 2.3 megacuries of cesium-137, with a 30-year half-life; and 0.3 megacuries of strontium-90 (which, like radon, seeks bone), also with a 30-year half-life. This airborne plume of material fell to ground—which is why it's called fallout—across Europe.
- ◆ About 130 plant workers and firefighters came down with acute radiation syndrome, and 30 of them died from the radiation exposure. There was population exposure from ingestion and ground exposure. The linear no-threshold hypothesis predicted about 9000 excess cancer fatalities.
- ◆ About 300,000 people were evacuated. There were several thousand measurable extra thyroid cancers due to iodine-131, which amounted to about 15 extra deaths from thyroid cancer.

- ◆ Significant areas of the Ukraine, Belarus, and western Russia were contaminated with about 5 curies or more per square kilometer. For a 100-kilogram person, this equates to an external dose of  $6 \times 10^{-4}$  joules per kilogram in a year, which is a dose of 60 millirem in a year. Our background radiation dose is 600 millirem, so this contamination was relatively small.
- ◆ This predicted a 70-year population exposure of 600,000 person-sieverts, or 60 million person-rem. In the first year, this increased the average radiation dose in non-former-Soviet Union Europe by about 8%. If we apply the linear no-threshold hypothesis, this predicts 9000 extra cancer deaths over 70 years—out of 100 million natural cancers.
- ◆ Twenty years after the accident, the United Nations Scientific Committee on the Effects of Atomic Radiation said that except for thyroid cancer, there was no evidence of a major public health impact caused by radiation exposure. (Thyroid cancers are otherwise very rare, so it's much easier to identify extra thyroid cancers than extra other kinds of cancer.)
- ◆ Today, there's a new, very expensive dome enclosing the reactor. They didn't think they needed it before the accident. You can tour the contamination zone.

## Fukushima

- ◆ The most recent nuclear accident was at the Fukushima Daiichi nuclear power plant, which had 6 boiling-water reactors, 3 of which were shut down at the time for refueling. Seawater cooling was used, which involves pumping in seawater to help cool the power plant. There was a 19-foot seawall to protect against tsunamis.



- ◆ There were lots of safety cooling systems. But those systems all needed electricity, supplied first by the power plant, second by power from the grid, third by 2 diesel generators per reactor, and fourth by battery backups that could run those plants for 8 hours.
- ◆ On March 9, 2011, there was a magnitude 7.2 earthquake. The reactor scrambled—so fission stopped—and then restarted. There was no problem. Just a few days later, on March 11, there was a magnitude 9.0 earthquake. The reactor scrambled, and fission stopped. Japan moved 8 feet closer to the United States. More than 383,000 buildings were destroyed by the earthquake. Only 41 minutes later, a 13-foot tsunami hit, with no damage, but 8 minutes after that, a 49-foot tsunami overwhelmed the seawall.

- ◆ The water intake structures collapsed. The pumps were blown down. The electrical lines were demolished. The basement generators were flooded. One above-ground generator survived for units 5 and 6. Units 3 and 4 were on battery power, with backup passive cooling for unit 3. Units 1 and 2 had no power.
- ◆ The operators scavenged all the car batteries in the parking lot to briefly power the controls, but unfortunately, there was no cooling for unit 1 and only backup passive cooling for unit 2. They needed cooling for the residual core power in reactors 1, 2, and 3. But roads were destroyed, the interconnect cables they could have used to connect the functioning generators with the nonfunctioning reactors were lost, and the existing 4-inch cables weighed a ton each.
- ◆ Unit 1 had no power. The water boiled away in a few hours. The fuel assemblies heated up, sagged, and collapsed. The 1-inch-thick reactor vessel burst. There was hydrogen gas in the containment building, and they needed to open the vent stack valves—manually, in a radioactive environment—to vent the hydrogen.
- ◆ They failed to reconnect power to the other units. The passive cooling eventually failed as the last of the water boiled away. There were hydrogen explosions from gas generated by the **meltedowns**, and the cores of units 2 and 3 also melted down.
- ◆ No spent fuel was damaged. All the radiation came from damaged cores exposed to steam. All the cores were contained in the pressure vessels. The maximum exposure was about 60 rem to 2 operators whose respirators didn't fit properly over their glasses and didn't seal.
- ◆ The radiation release was about 10% of Chernobyl. Radiation levels about 50 kilometers from Fukushima were only about  $\frac{1}{10}$  of what you get in an airplane. There was also lots of confusion and fear.

- ◆ The earthquake and tsunami damaged or destroyed about a million buildings, killed 18,000 people, and displaced more than 300,000 people. The nuclear accident killed zero people directly, caused 150,000 people to be evacuated from a 20-kilometer radius (and there were a few hundred deaths attributed to the evacuations), wrecked 4 very expensive reactors, and should cause about 130 expected extra cancer deaths (if we assume the linear no-threshold hypothesis). As a result of Fukushima, Japan shut down all of its power plants to evaluate their tsunami risk.

---

## Other Reactor Incidents

There were 5 major accidents before 1970 in test or experimental reactors. Together, they caused 3 deaths and 1 significant radiation release that might have resulted in about 300 expected thyroid cancers.

In Idaho Falls in 1961, a technician manually and rapidly removed a control rod. This increased the reactor power, led to a steam explosion, and killed 3 people.

At Browns Ferry in 1975, which was a commercial power reactor, there was a fire in the electrical wiring. There was no damage to the reactor, but there was a lack of redundant safety features that has since been corrected.

We have little knowledge of Soviet/Eastern Bloc accidents.

---

## Supplements

### READINGS

Bodansky, *Nuclear Energy*, chaps. 15.

Dworschak, “Is Radiation as Bad as We Thought?”

International Nuclear Safety Advisory Group, *INSAG-7—The Chernobyl Accident*.

Mahaffey, *Atomic Accidents*.

National Research Council, *Health Risks from Exposure to Low Levels of Ionizing Radiation*

———, *Nuclear Physics*, p. 209–212.

United Nations Scientific Committee on the Effects of Atomic Radiation, *Sources and Effects of Ionizing Radiation*.

### QUESTIONS

- 1 What made the Chernobyl accident so much worse than either Fukushima or Three Mile Island?
- 2 Why can't we measure the extra 9000 cancer deaths expected in Europe due to the Chernobyl accident?
- 3 How many things had to go wrong in series to cause the Fukushima meltdown?

## ANSWERS

- 1 In Fukushima and Three Mile Island, the nuclear reaction had been stopped. The reactor cores melted down because of the residual heat generated by radioactivity in the spent reactor fuel. The core meltdowns were contained by the containment vessels. At Chernobyl, the nuclear reaction had not been stopped and probably went out of control. Therefore, much more energy was released. In addition, the Chernobyl reactor did not have a containment vessel, so the explosion distributed the spent reactor fuel and its by-products over a huge area.
  
- 2 This is because about  $\frac{1}{5}$  of the population will naturally die of cancer, and this amounts to a total of about 50 to 100 million natural deaths from cancer. The extra 9000 deaths attributed to Chernobyl are only about  $\frac{1}{5000}$  of the overall rate. This tiny effect is impossible to measure, because it is less than the natural variation in the cancer death rate.
  
- 3 (a) The tidal wave had to be higher than the seawall, (b) the tidal wave had to knock out the power lines connecting the reactor to the outside world, (c) the tidal wave had to knock out the emergency generators, and (d) they had to be unable to connect the generator powering units 5 and 6 to the other units. The tidal wave overwhelmed the seawall at Fukushima II, but one of the power lines and some of the generators and pumps survived, so they could keep the reactor cores cool.



# 19

## THE NUCLEAR FUEL CYCLE AND ADVANCED REACTORS

**N**uclear fission power plants are getting better and better. The first-generation power plants, the initial plants, are all retired. The second-generation power plants, built beginning decades ago, are the ones that are now in service. They are safer, more reliable (providing power more than 98% of the time that they're expected to), and more fuel efficient. The third-generation power plants are starting to be built in the 21<sup>st</sup> century, and the fourth-generation power plants are being designed. The goal is to improve safety, radioactive waste, proliferation, and cost. ◆

## Third-Generation Power Plants

- ◆ The third-generation power plants are new light-water reactors. They are an evolution of existing design. They use thermal neutrons, which means that the neutrons are moderated, or slowed down. They have more passive cooling and active safety systems and are designed to be much simpler, with less wiring and piping, which should make them cheaper.
- ◆ Different designs are approved to be built in China, Europe, and the United States, and a few new plants are being built. They should be safer. But we don't know yet if they will be cheaper. They are going to burn more of their fuel, which means that they will require less fuel, reducing waste. They are good for proliferation because they use low-enriched uranium and leave the fuel in the core longer, reducing the bomb potential of the plutonium.
- ◆ How can we produce nuclear power more cheaply, more safely, with less waste and less risk of nuclear proliferation?
  - According to numbers from 2014, construction and finance costs dominate a nuclear plant, at 80% of the costs. The fuel costs are very small, about 10% of the costs. There is also a small surcharge for waste disposal. The big thing to reduce is construction costs.
  - For safety, we need to make sure that the reaction stops and that the coolant keeps flowing once the reaction has stopped.
  - We can reduce waste in a few ways: by improving the thermodynamic efficiency (if we can run the reactor at a higher temperature, then we need less fuel), using more of the fuel (burn up a higher fraction of the fuel in the reactor), and processing the waste to reduce the amount of waste. We can also transmute **transuranics**—elements

heavier than uranium, such as neptunium, plutonium, americium, and curium—or have a reactor that doesn't make transuranics and uses thorium.

It takes 3 gigawatts of energy released from nuclear fuel to make 1 gigawatt of electric power.

- For proliferation, we want to make less plutonium-239. When we do make it, we want to contaminate it with other plutonium isotopes so that it's much more difficult to use in a bomb.

## Spent Fuel

- ◆ Nuclear waste comes from the nuclear fuel cycle. About  $\frac{2}{3}$  of the nuclear fuel is used once through and then dumped. We put the fuel in a reactor, fission the uranium, get the energy out, and remove the spent fuel and dispose of it. In the United States, that's all that is done with the fuel.
- ◆ France, Great Britain, etc., reprocesses the spent fuel. They remove the uranium and plutonium from the spent fuel. This reduces the volume of the waste tremendously, and they can reuse the uranium and plutonium in other reactors.
- ◆ We can also breed more fuel and then reprocess and use it. We can use uranium-238 to breed plutonium and then fission that plutonium in a power plant. But uranium is a tiny fraction of the total cost of nuclear power, so there is very little financial incentive to reprocess the fuel or to breed more fuel.
- ◆ How do we use more of the fuel? We fission, or burn, more of the uranium. We can either fission the uranium-235 or convert the uranium-238 to plutonium-239 and fission the plutonium-239.

- ◆ The **burnup rates** have increased from about 2% in 1973 to 4.5% to 5% today. We use more enriched fuel; it's now about 4.5% uranium-235. To make that more enriched fuel usable, add burnable poisons to keep the reactivity constant. We leave the fuel in the reactor longer, which means that we need less fuel. More uranium-235 is consumed, and more plutonium is made and fissioned. We need to refuel less often. This is good because power plants need to be shut down to refuel and less time is wasted refueling.
- ◆ A higher burnup rate increases the plutonium production, but the fuel is spending more time in the reactor, which means that more plutonium-239 absorbs neutrons to make plutonium-240 and plutonium-242. The ratio of plutonium-240 to plutonium-239 increases. Plutonium-240 has a much higher spontaneous fission rate, which means that it's much more difficult to make bombs with it.
- ◆ How much radioactive waste has been made in the United States so far? It's split into categories. There are 20 million cubic meters of low-level waste. This is 90% of the volume of all nuclear waste but only 1% of the total radioactivity. Almost all of that is disposed in near surface, or special landfills.

---

Decommissioning a nuclear power plant is paid for by funds collected from the power plant or put aside by the power plant during operation. The plant material is much less radioactive than the spent fuel. In fact, almost all of it is low-level waste. Many power plants have been safely decommissioned.

---

- ◆ High-level waste includes the spent fuel. There are 22,000 cubic meters of high-level waste, which is about 1000 times less than the amount of low-level waste by volume. About 1000 cubic meters per year is being made. This is not that much for all of a country's nuclear power plants. High-level waste needs cooling. It's about 3% of the volume of all the waste we make and about 95% of the radioactivity.
- ◆ The spent fuel is very, very radioactive. There are some very-short-half-life nuclides that are very radioactive but decay rapidly. When the spent fuel is taken out of the power plant, there are about 7 gigacuries initially, which puts out about 40 megawatts of power, so it needs lots of cooling. A year later, there is 100 times less radioactivity, at 74 million curies, and 100 times less power, at 0.5 megawatts—so it still needs lots of cooling, via water bath. After 10 years, it decreases to about 14 million curies (about 5 times less), so we can take it out of water baths and air-cool it.
- ◆ What is left in the spent fuel? Strontium-90 and cesium-137, which have 30-year half-lives, decay first. Plutonium-241 decays to americium-241, which has a 400-year half-life. The long-term radioactivity (more than 100 years) is due to the transuranics—such as neptunium, plutonium, americium, and curium—and their daughter nuclei. After 10,000 years, the radioactivity is comparable to the natural radioactivity of the Earth.
- ◆ The spent fuel is initially very hot, both thermally and radioactively, so the fuel assembly is moved remotely. The fuel assembly is put in a water-filled cooling pool. It will be cool enough to reprocess the fuel after a few years, and it will be cool enough to put in dry storage after about 5 years. Dry storage involves steel casks with air cooling and multiple levels of containment. We don't have any long-term storage solutions yet.

- ◆ How do we safely dispose of anything for millennia? We use multiple barriers. We immobilize the waste in an insoluble matrix (borosilicate glass or uranium oxide fuel pellets). Then, we want to put the waste in a corrosion-resistant container, made of stainless steel. We isolate the waste from people and the environment deep underground in a stable rock formation. We fill it with an impermeable material to reduce water transport.
- ◆ About  $\frac{1}{3}$  of all spent fuel has been reprocessed. To reprocess it, we separate the uranium and the plutonium from the rest. The uranium and plutonium are much less radioactive, so the remaining radioactive waste has much less mass (but the same radioactivity).
- ◆ To recycle this spent fuel, we remotely dissolve the radioactive fuel rods in acid and extract the uranium and plutonium chemically. There is a proliferation risk from extracting the plutonium.
- ◆ We can reuse the plutonium. We make **mixed oxide fuel**: 95% uranium-238 and about 5% plutonium. Then, we can fuel our power plants with  $\frac{1}{3}$  mixed oxide fuel and  $\frac{2}{3}$  low-enriched uranium. The reason we don't use more mixed oxide fuel is that the plutonium-239 has a smaller delayed neutron fraction, so that makes it more difficult to control as a reactor fuel.

---

Yucca Mountain in the United States was designated by Congress as the sole US depository 30 years ago. It's not yet in operation because it's very politically contentious.

The Waste Isolation Pilot Plant in New Mexico is 2000 feet below ground in a salt formation. It's for bomb-related transuranic waste only, which is a much smaller volume of waste. In 2014, one of the drums of waste exploded, releasing some radioactive material, but it reopened in 2016.

## Advanced Fission Reactors

- ◆ There are 2 general types of advanced fission reactors: ones that use fast neutrons and ones that use slow neutrons (moderated thermal neutrons). Slow-neutron reactors use uranium-235 and a graphite or water moderator to slow down the neutrons.
- ◆ **Fast reactors** use uranium-238 or a mix of uranium-235 and plutonium-239. They don't use a moderator; instead, they use a heavy coolant. They use a mix of fissile and fertile fuel (the fissile part can fission and the fertile fuel can absorb a neutron) and make more fuel. Uranium-238 becomes plutonium-239, or thorium-232 becomes uranium-233, or plutonium is burned to reduce stockpiles. There are accelerator-driven subcritical reactors, and the advantage is that they are always subcritical.
- ◆ An example of a new thermal-neutron reactor design is the high-temperature gas-cooled reactor, which is helium-cooled and graphite-moderated. Helium doesn't absorb neutrons, which means that if there is less coolant, then there is no positive feedback from cooling water boiling, like Chernobyl had.
- ◆ This type of reactor runs in higher temperatures (1000° Celsius), which means more thermal efficiency. If the temperature in the core increases, then the uranium-238 atoms in the fuel move faster, which means that the uranium-238 can absorb more neutrons, which is negative feedback.
- ◆ With this type of reactor, there is also a smaller ratio of fuel to moderator, so there is a greater thermal inertia and less temperature increase if it loses cooling. The fuel is stable up to 2000° Celsius, but air must be kept out because carbon can burn and cause a fire. This reactor uses 8% enriched fuel. It makes 1-millimeter microspheres of fuel encapsulated in layers of protective carbon. It should be safer, and

we don't know if it will be cheaper. But there will be more thermal efficiency, so it needs less fuel and produces less waste. There's no change in proliferation.

- ◆ One of the concepts for this high-temperature gas-cooled reactor is a **pebble-bed reactor**, where there are 1500 of these microspheres in each 6-centimeter carbon pebble. It uses about half a million pebbles for a reactor. The pebbles are continually inserted at the top and removed from the bottom, so there is no need to shut down the power plant to refuel.
- ◆ There are also fast reactors, where “fast” refers to the neutrons. These use a mix of fissile and fertile fuel—plutonium or uranium-235 to fission and uranium-238 and thorium-232 to make more fuel. These 2 isotopes of uranium and thorium are 99% abundant. We don't need to do any enrichment.
- ◆ There is no moderation that uses fast neutrons. The plutonium has a low-absorption cross section for neutrons but a high-fission cross section (of 2 barns), so it's much more likely to fission than to absorb a neutron. The coolant needs to be a high-mass coolant, such as sodium metal or sodium chloride.

#### PEBBLE BED REACTOR SCHEME

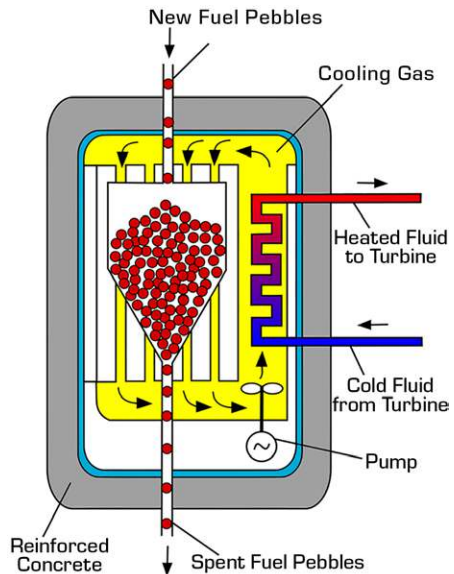

- ◆ We can reprocess the spent fuel. We can separate out the transuranics and return the uranium and plutonium to the reactor in new fuel rods. The safety of the fast-neutron reactor is due to negative temperature feedback. Increased temperature means the core expands thermally, which means less density and less reactivity.
- ◆ We don't know yet if a fast-neutron reactor is cheaper, but it does produce less waste because it breeds more fuel and burns the waste. It could be run to just burn plutonium, reducing the plutonium stockpiles, or it could make more plutonium and chemically separate it for use in other reactors.
- ◆ There are different coolants for fast-neutron reactors. They can use helium at high pressure and at high temperature, so there is high thermal efficiency. We can use molten lead, the advantage of which is that it's low pressure and relatively inert. Or we could use sodium, which is also low pressure and has a more advanced design.
- ◆ We can even dissolve the fuel in the coolant, which would be a **molten-salt reactor**. We dissolve the fuel in the molten salt, and it circulates through separated channels in graphite and is brought together in the core, where it can fission. There is some moderation because of the graphite. It's self-breeding and uses fertile fuel, either uranium-238 or thorium-232. It can achieve very high burnup, but there are no prototypes yet.
- ◆ Another exciting possibility is a liquid fluoride-thorium reactor, which would be a fast breeder. We would flow liquid thorium fluoride through the core and mix it with lithium fluoride or beryllium fluoride to get the melting point down to 360° Celsius. Fission occurs only in the core, and the heat is transferred at 700° Celsius to a gas, such as carbon dioxide or helium, which then drives turbines.

- ◆ We start with some low-enriched uranium and thorium to get the reaction started. The uranium-235 fissions, and the thorium-232 absorbs neutrons to make fissionable uranium-233. It breeds new fuel, so we don't need any more low-enriched uranium after startup. We continuously remove the waste and add new fuel to the liquid.
- ◆ The liquid fluoride-thorium reactor should be safer. It works at atmospheric pressure, so we don't need high-pressure systems. The waste should be much less radioactive, with a much shorter half-life—centuries, not millennia. There is a reduced proliferation risk because it is much more difficult to make a uranium-233 bomb due to some very radioactive thallium, which is the decay product of uranium-233. We don't know yet if it would be cheaper.
- ◆ Then there is **accelerator-driven fission**. We take a subcritical reactor and supply extra neutrons from the accelerator. We accelerate protons to about 1.6 billion electron volts, hit a molten mercury or lead target, and knock out lots of neutrons. We moderate the neutrons, and this then makes the reactor go. In terms of safety, it's always subcritical, but—because we would need the accelerator—it would be more complicated and more expensive.

	SAFETY	WASTE	PROLIFERATION	COST
3RD GEN LWR	✓	✓	✓	???
HTGR	✓	✓	✓	???
FAST NEUTRON	✓	✓	✓	???
MOLTEN SALT	✓	✓	✓	???
LIQUID THORIUM	✓	✓	✓	???
ACCELERATOR DRIVEN	✓	✓	✓	<b>X</b>

- ◆ To reduce costs, we can make lots of reactors from the same design. We can use small modular reactors, for which there are many projects and designs. They should have reduced size and reduced complexity, be built in factories so that they're cheaper, and be transportable so that there are more places that they can be used.
- ◆ There are many fascinating possible reactor technologies on the horizon. There are many private companies involved in developing improved light-water reactors, pebble-bed reactors, fast-neutron reactors, thorium-fluoride (molten-salt) reactors. All of them should be safer. Most designs are more complicated, such as breeders, or need a lot of research and development, such as thorium fluoride. The small modular reactors are most likely to expand usage and reduce construction costs. There are many interesting possibilities, but unless they are a lot cheaper to construct, they will never become the next generation of nuclear power.

## Supplements

### READINGS

“Asgard’s Fire,” *The Economist*.

Bodansky, *Nuclear Energy*, chap. 16.

Fountain, “On Nuclear Waste, Finland Shows U.S. How It Can Be Done.”

MIT Center for Advanced Nuclear Energy Systems Symposium,  
*Nuclear beyond LWRs*.

Nutall, *Nuclear Renaissance*.

Temple, “Small Reactors Could Kick-Start the Stalled Nuclear Sector.”

World Nuclear Association, “Advanced Nuclear Power Reactors.”

———, “Storage and Disposal of Nuclear Waste.”

## QUESTIONS

- 1 How much less radioactive is the spent fuel from thorium fission than from uranium fission?
- 2 Why is negative feedback in a reactor so important?

## ANSWERS

- 1 There is little difference in the radioactivity in the first 100 years, because that is dominated by the radioactive decay of fission products, especially cesium-137 and strontium-90. However, after 200 years, most of the radioactivity comes from transuranics (plutonium isotopes and their decay products). These are not present in spent fuel from thorium fission.
- 2 This is important for stable operation. Negative feedback means that when the reactor rate increases for any reason, other properties will change to decrease it, and when the reactor rate decreases for any reason, other properties will change to increase it. For example, in a standard boiling-water reactor, if the reactor rate increases, then more water will boil. This will decrease the amount of water in the reactor vessel, which will decrease the neutron moderation and therefore decrease the reaction rate. The primary cause of the Chernobyl reactor accident was that the reactor did not have enough negative feedback, so when the reactivity increased, the only way to decrease it was to manually insert the control rods, which were much too slow.



# 20

## NUCLEAR FUSION: OBSTACLES AND ACHIEVEMENTS

**N**uclear fusion means fusing hydrogen to become helium, releasing energy. It promises clean, carbon-free power with no worries of catastrophes, nuclear proliferation, nuclear waste, or running out of fuel. Unfortunately, nuclear fusion has been promised for 50 years. Some say that fusion power is 50 years away, has always been 50 years away, and always will be 50 years away. ◆

## Fusing Deuterium and Tritium

- ◆ With nuclear fusion, we're bringing the energy supply of the cosmos down to Earth. How can we tame it? We need to overcome the electric repulsion so the 2 nuclei can meet and fuse. We want to fuse isotopes with the fewest number of protons so that they have the lowest electrical repulsion. We want to end up with helium-4 so that we can get lots of energy.
- ◆ We could do what the Sun does and fuse proton to proton, but we don't have the billions of years that the Sun has to wait for a few proton nuclei to collide. We could fuse a proton and deuterium, but that has a very low probability and very little energy is released. We could fuse 2 deuteriums to make helium-4 and a gamma ray; we get a lot of energy that way, but there is a small cross section because it's an electromagnetic interaction, not a strong interaction. We could fuse 2 deuterons to make helium-3 plus a neutron, or tritium plus a proton, but that's relatively low energy.
- ◆ Or we could fuse deuterium and tritium to make helium-4 plus a neutron, which releases 18 million electron volts of energy. That looks like the right one to try.
- ◆ Tritium is radioactive. What if instead we fuse deuterium and helium-3 to make helium-4 plus a proton, releasing 18 million electron volts of energy? This is great. Our fuel's not radioactive. We don't have those pesky neutrons at the end—we have protons. The problem is we're using helium, with more electrical repulsion, so the reaction needs temperatures that are 6 times higher. We're probably not going to fuse deuterium and helium-3 this century.
- ◆ We need to confine our fuel—so far, typically deuterium and tritium—at high density and pressure for long enough for them to fuse. There are 3 ways to confine the nuclei so that they will fuse: gravitational confinement, inertial confinement, and magnetic confinement.

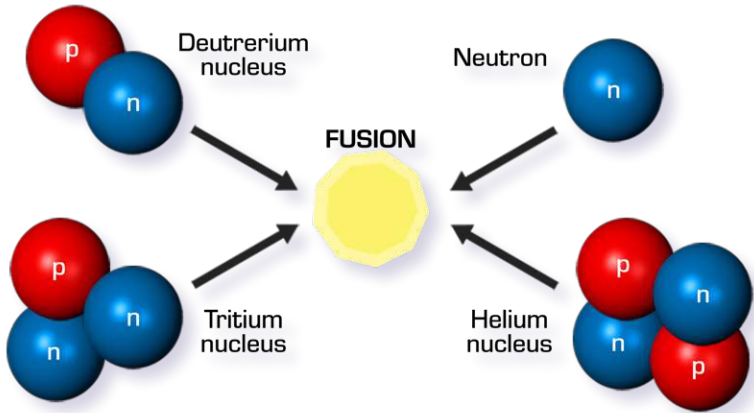

- ◆ Why is fusion so attractive? There are no transuranics, such as plutonium, and there is no long-term (thousand-year-plus half-life) radioactive waste. There is unlimited fuel. We can get deuterium from seawater by vacuum distillation, and we can make tritium from lithium-6 by hitting it with a neutron. A neutron plus lithium-6 becomes an alpha particle plus tritium.
- ◆ Also, fusion has 10 times more energy density than fission. Fusion is fail-safe. The fuel is continuously supplied. If the confinement fails, the reaction stops. There is no critical mass of uranium-235. There is no stored energy, like there is with fission. With fusion, we don't have to worry about the residual decay heat for the loss-of-coolant accidents that happened at Fukushima. The plasma is hot, but it has so little mass that it has little stored energy.
- ◆ There are no proliferation concerns because there is no enriched uranium. There is no plutonium. But we need tritium, which is radioactive and biologically active, and it needs to be produced. Fusion produces neutrons, and there is neutron irradiation, which damages reactor materials and creates some radioactive material.

- ◆ We need very high temperatures and high densities for long enough to make the nuclei fuse. The high temperature makes a plasma, which is where the electrons and the nuclei move independently, such as in fluorescent light bulbs and in candle flames.
- ◆ We need the density to be high enough so that nucleus-nucleus collisions allow for fusion. We need high enough temperatures so that nuclei tunnel through the electrical repulsion to fuse. This is the same effect as tunneling for alpha decay. A small change in energy makes a big change in the probability, so we need temperatures of 10,000 to 20,000 electron volts, or 100 to 200 million Kelvin. We also need confinement times that are long enough so that we get enough fusion out.

## Plasma Confinement and Heating

- ◆ With fusion, 2 nuclei at a temperature of about 20,000 electron volts collide and release about 20 million electron volts. A 14.1-million-electron-volt neutron leaves the plasma, and we catch it in a “blanket” to make heat to make electricity.
- ◆ The alpha particle has 3.5 million electron volts, and it deposits its energy in the plasma. This helps keep the plasma hot. We get out 500 times more energy than we put in, but not all of the nuclei fuse. The break-even point is at a temperature of 10,000 to 20,000 electron volts, or 100 to 200 million Kelvin. The density times the time is greater than  $10^{20}$  nuclei per cubic meter times seconds, which would be a confinement of 1 second at 3 atmospheres of pressure. At that point, it would be about a million times less dense than air.

- ◆ The  **$Q$  value** is the energy released divided by the energy needed to heat the plasma. The break-even point is a  $Q$  value of 1, but 80% of the energy is carried away by the neutron. It is used to make electricity, not to heat the plasma. We need a  $Q$  value that is greater than 5 to keep the plasma hot.
- ◆ How do you confine a hundred-million-degree plasma? We use a magnetic bottle. Charged particles moving in a magnetic field feel a force perpendicular to the field. There is no force that is parallel to the field, which means that the particles spiral along the magnetic field lines.
- ◆ How do you confine the particles in the third dimension (along the field lines)? We make the magnetic field lines circular so there is no end. This is called a **tokamak**, which is a Russian acronym for a toroidal chamber with magnetic fields.
- ◆ We take a solenoid, which is a wire wrapped around a cylinder, and bend the ends together to form a circle. The coils make a toroidal magnetic field, or a doughnut. The particles moving radially outward from the inside of the doughnut spiral around the magnetic field lines and stay in the torus. But the field is weaker farther from the center, so the configuration is not quite stable.

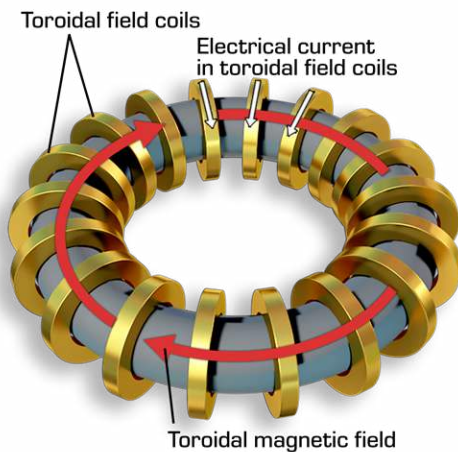

- ◆ Next, we give the magnetic field lines a twist. We pass a current around the torus to add a poloidal field, and now the field lines—instead of going around in circles—trace out helices around the axis of the torus. That will confine the particles.

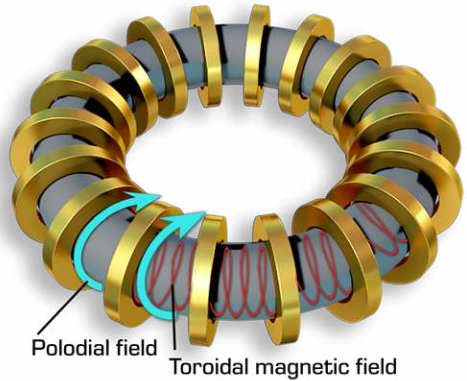

- ◆ To make a toroidal current to get the poloidal field, we make a transformer—which has a primary and a secondary—with  $N$  windings around the primary and an iron core to induce a current in the plasma that makes the current  $N$  times bigger going through the secondary.

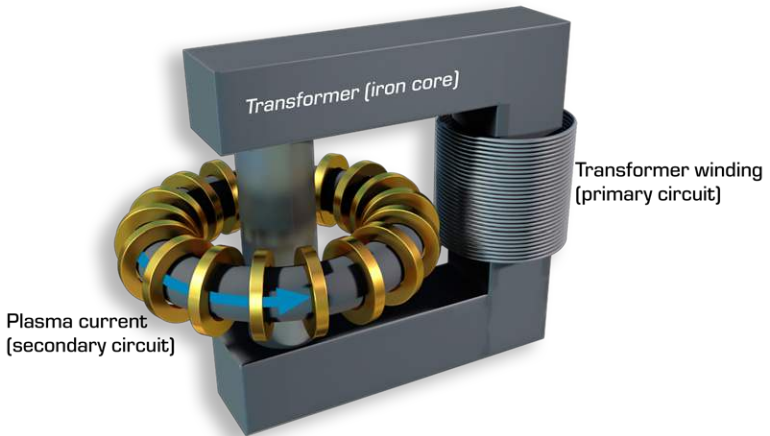

- ◆ Most transformers use alternating current, so the primary current varies continuously in a sine wave. That creates a secondary current that also is a sine wave. But the transformer for a tokamak uses direct current, where the primary current increases steadily up to a maximum, thus creating a constant secondary current.
- ◆ But it can't run continuously, because there is a maximum current. So, we turn everything on, increase the primary current to the maximum, and then turn everything off to reset and repeat. The timescale of this is between minutes and tens of minutes. This could be a problem if we want to use a tokamak for baseload power generation.
- ◆ Once we confine the plasma, how do we heat it up? The current provides some power, but it's not enough. We can use radio waves to heat the plasma at the natural frequency of the electrons or of the nuclei in the plasma. This is like a microwave oven heating water at its resonant frequency. We can also aim neutral particle beams at the plasma, which adds energy and deuterium or tritium to the plasma.
- ◆ A fusion experiment needs a vacuum vessel for the plasma, superconducting magnetic coils to make the magnetic field to contain the plasma, a transformer to create the toroidal current, and external radio-frequency and beam heaters for the plasma. We need to protect the superconducting magnetic coils, which are really cold, from the hundred-million-degree plasma as well as protect the delicate electronics from the neutron radiation.
- ◆ If we want to make a fusion power plant—not just do a fusion experiment—we want to generate electricity, so we need a blanket to absorb the neutrons and the energy of the neutrons. The blanket has to have high-temperature tolerance. Graphite is good, but it absorbs tritium. We also have to worry about the blanket being eroded by the plasma; if that happens, some of the material from the blanket can get into the plasma and contaminate it.

- ◆ Next, we need a coolant to extract the heat from the blanket. We typically use water or helium gas. The coolant then boils the water to turn a turbine to make electricity. We need lithium in the absorbing blanket to absorb neutrons and generate more tritium. Neutron plus lithium-6 gives us helium-4 plus tritium. We also need a **diverter** to remove the helium-4 “ash” from the plasma. (Ash is the product of our burning or fusion, and it gets in the way of more reactions.)

## FUSION POWER PLANT

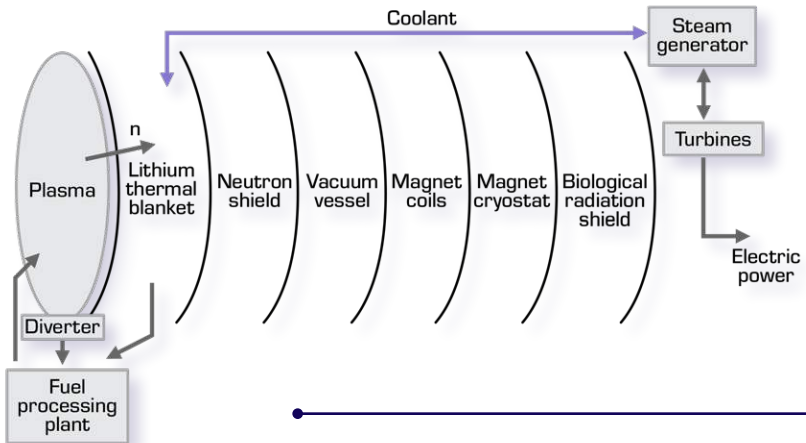

The layers of a fusion power plant include the plasma with a diverter to remove the helium-4, a thermal blanket with lithium to make tritium to be recycled as fuel, a neutron shield, the vacuum vessel (contains the plasma), the magnet coils and magnet cryostat, and the biological radiation shield.

---

## Cold Fusion

Stanley Pons and Martin Fleischmann announced in 1989 at a press conference that they had discovered cold fusion. They didn't give any real details, but there was a scientific frenzy around the world to reproduce the experiment. There were lots of anomalous results or partial confirmations.

Pons and Fleischmann ran a current through 2 electrodes in an electrolysis cell, which separates the water into hydrogen and oxygen. They used palladium electrodes; palladium can absorb lots of hydrogen. They used heavy water (deuterium) and claimed to see fusion.

But what they actually saw was anomalous heat. They claimed to see heat above and beyond what they put in. They saw a few neutrons. How could this possibly work at room temperature? They claimed it was due to the much higher hydrogen density in the palladium electrodes. But the deuterium nuclei still need to tunnel through the electrical repulsion barrier to fuse. They're at a much lower temperature and therefore have much less kinetic energy and a much smaller fusion probability. The alpha-decay half-lives change dramatically with kinetic energy.

In addition, deuterium-deuterium fusion should also release radiation. Deuterium plus deuterium fuses to make helium-3 plus a neutron. But they didn't detect enough neutrons by a factor of about 1 million. With the energy release they claimed, there should have been a lot of radiation. There were 10 watts of fusion power, so they should have gotten a few rem every second.

When they tried the experiment again with regular water (protons), which can't fuse to make helium, they got the same results as they did with heavy water. That was a problem. If there was fusion, they should have seen helium in the electrodes, but they didn't find any. There are still some enthusiasts looking for cold fusion, but most physicists and chemists are not.

---

- ◆ For inertial confinement fusion, we hit a pellet of frozen fuel from all directions at the same time to compress it. We hit it with lasers or particle beams. Today, we mostly use lasers.
- ◆ At the National Ignition Facility (started in 2009) in the United States and at Laser Mégajoule in France, they use lasers to implode frozen deuterium-tritium pellets. They heat the pellet surface, creating a shockwave that implodes the fuel.

How close are we getting to controlled fusion?

The maximum fusion power was produced by the Joint European Torus (JET) tokamak in 1997 with a  $Q$  of 0.64 for about 10 seconds. There has been tremendous progress since the 1960s, but there is still a long way to go.

- ◆ There is also indirect drive, which involves hitting a cylinder called a hohlraum with lasers, creating x-rays that compress the fuel pellet. The expected density is about 1000 times the density of water, and the pressure to do this is 300 billion times atmospheric pressure.

## Other Techniques to Confine Plasma

- ◆ Magnetized target fusion, which is a mix of inertial and magnetic confinement, involves making a spinning liquid metal sphere with a hole through the middle and shooting plasma rings in from the top and bottom to make a target in the center. Then, a few hundred pistons ram the surface hard enough to send a shockwave through the liquid metal to compress the plasma target. This is being done by General Fusion in Vancouver.

- ◆ A colliding beam fusion reactor involves making 2 plasma clouds, accelerating them to fusion energies, colliding them, and then heating them further with plasma beams. This is being done by Tri Alpha Energy, which in 2015 achieved a stable plasma that lasted for 5 milliseconds (a really long time for a plasma).
- ◆ Inertial electrostatic confinement, or polywell fusion, is being pursued by many groups. External electric fields by themselves can't contain charged particles, so they use magnetic fields, too. They trap electrons and use the trapped electrons to attract ions. They have achieved 10,000 volts, which is enough to accelerate the ions and achieve low-rate fusion. It's easy to make and confine plasmas, but it's more difficult to make some fusion, and it's not clear whether it's possible to achieve enough fusion for breakeven.

## Next Steps for Tokamaks

- ◆ There are some variants of tokamaks:
  - Spherical tokamaks look like a cored apple rather than a ring doughnut. The advantage is better magnetic pressure.
  - A stellarator is a twisted tokamak. The advantage is there is no need for a pulsed transformer to make a toroidal current. It can operate continuously. But the disadvantage is that it has a more complicated magnetic field and coils. This is being pursued in Germany with a \$1 billion prototype.
- ◆ The next step for tokamaks, though, is bigger ones. The International Thermonuclear Experimental Reactor (ITER) Tokamak, which will be huge and expensive (about \$14 billion), is being built in France by a collaboration of the European Union, the United States, Japan, Russia, China, India, and Korea.

- ♦ ITER was started in 2013, and the first experiments are expected in 2025. Full deuterium-tritium fusion measurements are expected in 2035. The goal is to generate 500 megawatts for 1000 seconds with a  $Q$  factor of 10 (which is 10 times more energy out than put in).
- ♦ Technical challenges of ITER include the fact that ash diverters are needed to remove the alpha particles, and they have to work at extreme temperatures with lots of neutron irradiation. They need to get the blanket right to absorb the neutron energy. ITER needs to have high reliability if it's going to be a power plant, and it needs structural integrity and material strength to survive the high temperatures, neutron bombardment, and stresses from cycling magnetic fields.
- ♦ The plan is 10 years to build it, 10 more years of experiments building up to deuterium-tritium fusion, 15 more years to build a demonstration power plant, and another 15 years to commercialize it—or one of the novel startups might succeed. If all goes well, controlled nuclear fusion might actually be here in 50 years.

## Supplements

### READINGS

- Clery, “Fusion’s Restless Pioneers.”  
 Hamilton, “A New Approach to Fusion.”  
 Lilley, *Nuclear Physics*, chap. 11.  
 Nutall, “Fusion as an Energy Source.”  
 ———, *Nuclear Renaissance*, chaps. 9–11.  
 Park, *Voodoo Science*.

## QUESTIONS

- 1 The difference in the binding energies of hydrogen and helium is 7 MeV per nucleon, and the difference in the binding energies of uranium-235 and its decay products is only 1 MeV per nucleon. Why does fissioning 1 uranium-235 nucleus yield almost 10 times more energy than fusing hydrogen into 1 helium nucleus?
- 2 Neutron irradiation from fusion power plants is a concern. How does this compare to neutron irradiation from existing fission power plants?
- 3 Why are future fusion power plants (once they are made to work) likely to be less reliable than fission power plants?

## ANSWERS

- 1 Helium only has 4 nucleons, so fusing hydrogen into 1 helium nucleus only releases  $4 \times 7 = 28$  MeV total. Uranium has 235 nucleons, so fissioning uranium-235 releases  $235 \times 1 \approx 200$  MeV. However, in terms of energy released per kilogram of fuel (rather than per nucleus fissioned or fused), fusion releases 7 times more energy.
- 2 Uranium fission releases 2 to 3 neutrons for each fission, or about 1 neutron for each 100 MeV of energy released. Deuterium-tritium fusion releases 1 neutron for each fusion, or 1 neutron for each 28 MeV of energy released. Thus, for the same power production, fusion will release about 4 times more neutrons than fission. In addition, fusion plants will be more complicated, with superconducting magnets and other apparatuses that might be more susceptible to neutron damage.

3 It took the fission industry decades to figure out how to run their power plants reliably. Fission power plants just boil water like coal-fired power plants. Fusion power plants will be much more complicated than fission power plants. Fusion power plants will have hundred-million-degree plasmas just a few meters from ultracold superconducting magnets. They will have complicated transformers, beam heaters, ash removers, etc. In addition, 80% of the energy is carried away by the neutrons, so they will need to capture the neutrons and convert that energy to heat. All of this adds tremendous complexity that will make fusion power plants less reliable.



# 21

## KILLING CANCER WITH ISOTOPES, X-RAYS, PROTONS

**T**he field of radiation oncology uses radiation to treat cancerous tumors. It employs 2 kinds of radiation: internal and external sources. Internal sources use radioactive materials that are encapsulated and placed in and around the tumor. They are best for well-defined tumors in a single location but can also be attached to a molecule that seeks out the tumor and is injected into the body. This is the best method if the delivery is selective enough. External sources use beams of photons (x-rays or gamma rays), protons, neutrons, or ions and are aimed at the tumor from the outside. ◆

---

In 1916, a gynecologist named Dr. Howard Kelly, who was one of the founders of The Johns Hopkins Hospital, used radiation to treat 350 patients with advanced deep-seated cancers. He “milked” radon-222, which is a gas that has a half-life of 4 days, from radium. There is alpha, beta, and gamma radiation from the decay chain.



**DR. HOWARD KELLY**  
1858–1943

He placed the radium in tiny capsules called **seeds**, and lots of these seeds were positioned in and around the tumors. He cured 20% of his patients. This was a tremendous success for patients who were otherwise going to die. Today, our success rate for these cancers is about 70%.

---

## Internal Radiation

- ♦ What are the ideal characteristics of an internal radioactive source? We want the energy to be deposited in the tumor, not the healthy tissue. If the isotope travels to the tumor (i.e., iodine-131 travels to the thyroid gland), then we prefer that the radiation has the distance of microns, so we use very-short-range radiation, such as alpha particles or low-energy beta particles.

- ◆ If it's an implanted source (i.e., iridium-192 to treat prostate cancer), then the seeds or catheters where the iridium-192 is placed will be spaced millimeters apart, so we want the radiation to travel millimeters to cover all of the tumor in between the seeds or catheters. Therefore, we want to use short-range, low-energy x-rays or gamma rays. If the isotope is left in, as it is with radioactive seeds, then ideally the decay time of the isotope should be matched to the treatment length.
- ◆ How can we get the radioactive material—the radiopharmaceutical—to travel to the tumor? Iodine (element 53) travels to the thyroid as sodium iodide. It's used to treat thyroid cancer and hyperthyroidism. Iodine-131 has a half-life of 8 days. The decay chain of iodine-131 is mostly beta rays with 0.6 MeV maximum energy and 0.4 MeV gamma rays. The range of the beta rays is about 2 millimeters.
- ◆ The beta rays irradiate the tumor. The gamma rays (photons) have a longer range and irradiate the whole body, giving the whole body a dose of about 10% of what the thyroid gets. The radiation is not ideal, but iodine targets the thyroid so well that we use it.
- ◆ We make the iodine in a nuclear reactor. We place tellurium, which is 34% tellurium-130, in a nuclear reactor. A neutron hits tellurium-130 and makes tellurium-131, which decays to iodine-131. Most of the iodine-131 is gone from the body after 3 to 5 days. It is excreted via the urine or decays.
- ◆ If we want to treat bone cancer metastasis, then we take advantage of the fact that radium is a bone seeker. It's in the same column of the periodic table as calcium and strontium. Strontium-90 emits beta rays, which have a longer range and are not as useful. Radium is heavier than strontium and thus alpha-decays. The alphas have a range of between 2 and 10 cells, and they deposit much more energy in one place, so they are much more lethal to cells. The half-life is 11 days.

- ◆ To make radium-223, we put radium-226 in a reactor, and a neutron plus radium-226 makes radium-227, which beta-decays to actinium-227 (with a half-life of 22 years), which decays to thorium-227 (with a 19-day half-life), which then decays to radium-223. We purify the actinium. The actinium decays and makes more radium, and we extract the radium as needed. This is called an actinium/radium generator.
- ◆ If we can't get the radioactive material to transport itself to the tumor, then we implant the material. This is called **brachytherapy**. We can implant it in the body either temporarily via implanted tubes (catheters) or permanently in seeds. We insert lots of seeds or catheters to get good dose uniformity throughout the cancer. This allows us to concentrate the dose in some tumors better than with external beams. The total dose delivered to the tumor is typically between 30 and 150 gray, or between 3000 and 15,000 rad.
- ◆ The dose rate depends on the treatment plan designed by the oncologist for each patient. There are 2 dose rates: high-dose rate and low-dose rate.
  - High-dose rates (more than 12 grays an hour, or 1000 rad an hour) are given as discrete treatments. We infuse the radioactive material into the catheters, preferably remotely, and remove the radioactive material after each relatively short treatment. Isotopes used are iridium-192 or cobalt-60.
  - Low-dose rates (less than 2 grays an hour, or 200 rad an hour) are typically given with implanted seeds that are left in place. The seeds are filled with iodine-125 or palladium-103.
- ◆ We want to implant isotopes with a medium half-life (days to weeks). The shorter the half-life, there is more radioactivity, but we want the half-life long enough so that we can handle it. We want the half-life matched to the treatment length for permanent implants (seeds).

The first x-ray beam was applied to Hodgkin's disease by Dr. Henry Kaplan at Stanford in the late 1950s. Hodgkin's disease is a disease of lymph nodes, typically in the chest. The tumors are deep but have well-defined locations. The cancer progresses one lymph node at a time, so it doesn't metastasize to faraway locations in the body. He cured 50% of early-stage patients. Today, the cure rate is more than 90%.

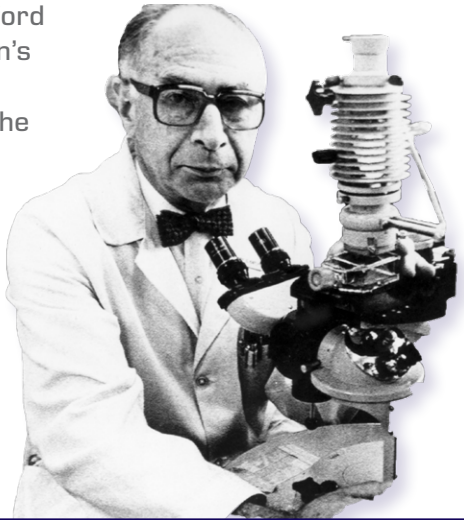

---

**DR. HENRY KAPLAN**  
1918–1984

- ◆ We want to use x-rays or low-energy gamma rays so that the range of the particle is about the same as the spacing of the seeds. Alpha and beta particles have too short of a range to get uniform coverage.
- ◆ We don't want the decay products to be gaseous because gas molecules can escape and migrate, and they increase pressure because they take up more space. We want this to be nontoxic, and we need to be able to sterilize everything.

## External Radiation

- ◆ If it's too difficult to implant seeds or put in catheters—perhaps because the tumor is the wrong shape or size or too diffuse—then we use beams of external radiation. We can use x-rays or gamma rays (photons), protons, or other particles.
- ◆ The particles have to have enough energy so that they can reach the tumor, and we need to minimize the dose to the surrounding tissue. We spread the dose over time to let the healthy tissue recover in between.
- ◆ Rapidly dividing cells are more sensitive to radiation, and that doesn't depend on the dose rate, but slowly dividing cells (such as skin cells and normal body tissue) are less sensitive to radiation, and the sensitivity is reduced at lower-dose rate as the cells recover.
- ◆ When an x-ray or gamma-ray photon passes through the body, it interacts discretely and transfers all of its energy to an electron, which keeps moving and ionizes atoms along its path until it runs out of energy. This means that the photon beam is most intense as it enters the skin (and deposits more energy there) and then loses intensity as the photons interact. The beam therefore deposits less energy the deeper into the body it goes.
- ◆ To make x-rays or gamma rays, we use an electron linear accelerator with between 6 and 20 million electron volts. The electrons hit a tungsten target and make x-rays. All of the x-ray or gamma-ray energies from zero to the electron energy are made. This is the same way that we make lower-energy x-rays for imaging purposes.
- ◆ We choose the energy to match the depth of the tumor. The deeper the tumor, the higher the energy and increased range of the x-rays or gamma rays. We want to collimate the beam horizontally so that the

shape of the beam matches the shape of the tumor. One beam will deposit most of its energy at the skin; 2 beams from different angles that overlap at the tumor will give more dose to the tumor.

- ◆ Modern treatments aim the beam at the tumor from multiple orientations to maximize the dose to the tumor and minimize the dose to the surrounding tissue. They know where to aim because very careful imaging is done before and, especially, during treatment. Image guidance is used. Careful computations and simulations are done by a medical physicist to maximize the dose to the tumor and minimize the dose to the healthy tissue.
- ◆ In intensity-modulated radiotherapy, each of the individual beams is shaped to best match the tumor size and shape. The high-dose regions (where we want to deliver a high dose to the tumor) are much tighter, or much better matched to the tumor, but the low-dose regions (where we irradiate healthy tissue) are bigger.
- ◆ A newer method, first approved for treatment of certain tumors in 1988, is [proton therapy](#). Protons and photons interact very differently in matter.
- ◆ To attack cancer, we want to deliver a lot of energy to the cancer cells and as little energy as possible to the healthy cells around them. When a photon beam travels through the body, each photon only interacts in one location, and the photon is either absorbed or not. The number of photons (and dose rate) decreases exponentially as it travels through body tissue. The highest dose is at the skin, but there is some dose at all depths. A higher-energy beam penetrates further than a low-energy one.
- ◆ Because protons are charged particles, as a proton beam travels through the body, it interacts with the electrons, exciting them and depositing energy as it goes. The energy it deposits increases the more slowly the proton travels.

- ◆ Unlike the photon beam, where the energy deposited is at a maximum as it enters the body and then decreases slowly as it travels through the body, the energy deposited by a proton beam is at a minimum as it enters the body, increases dramatically as it gets to where the tumor is, and then the protons stop because they have run out of energy.

- ◆ With a proton beam, we can be much more precise in how we deposit energy in the body; the proton beam deposits most of its energy in the tumor and no energy past it. Another advantage to a proton beam, in comparison to a photon beam, is that we can have a pencil-thin beam that only hits the area of the tumor.

- ◆ If proton beams can deposit energy in the tumor so much more precisely than photon (x-ray or gamma-ray) beams, then why doesn't everyone use them? Proton beams are much more difficult to make. We need protons of about 200 million electron volts to penetrate the body. We need to use a cyclotron to accelerate the protons. We ionize the hydrogen atoms and inject them into the cyclotron. The protons in a cyclotron spiral outward in a magnetic field, getting a small push twice each orbit. When the protons reach 230 million electron volts (about half the speed of light), they leave the cyclotron and are steered by magnets to the different treatment rooms.

Neutrons have the same mass as protons and can also do a lot of damage to tissue, but neutrons are much more difficult to accelerate and control because they have no charge. Neutrons are much more difficult to aim because they penetrate materials. Neutrons don't slow and stop precisely at a given depth, like protons, because they have no charge. There have been attempts to treat cancer with neutrons, but the neutrons were not effective enough to be worth the extra effort.

- ◆ How do we control the depth of the proton beam? We can make a narrow beam of protons, scan it across the tumor, and change the energy of the beam as it scans to match the tumor depth at each point. The lower-energy protons don't penetrate as far; they deposit their energy closer to the surface. Alternatively, we can diffuse the beam and then make a plastic "mask" to match the depth profile of the tumor.
- ◆ Proton therapy should be better than photon therapy, because there is better control of the dose. More importantly, we now have precise imaging to take advantage of that better control. But protons are much more expensive than photons, so we need to measure the improvement to see if it's worth the cost.
- ◆ There is a major National Institutes of Health initiative to perform randomized, controlled trials of proton versus x-ray therapy.
- ◆ What's next? With targeted radioimmunotherapy, we attach a short-lifetime alpha emitter to a biologically active molecule that targets the cancer (i.e., antibodies). With boron-neutron capture therapy, we attach boron to a cancer-seeking molecule and irradiate the patient with a thermal-neutron beam. The boron absorbs neutrons much more than anything else in the body. Boron-10 plus a neutron gives us lithium-7 plus an alpha particle, which kills the cancer.
- ◆ Radioisotopes can kill cancer cells, but radiation is much more common in medical diagnosis.

## Supplements

### READINGS

Jorgenson, *Strange Glow*, chap. 6.

Lilley, *Nuclear Physics*, chap. 9.

National Research Council, *Nuclear Physics*, p. 150–158.

### QUESTIONS

- 1 Why are radiation doses for cancer treatment about 10 times greater than the lethal radiation dose for people?
- 2 Why do patients often feel sick after receiving radiation treatment for cancer?
- 3 Why do we make sure that implanted radioactive seeds do not use any materials with gaseous daughter nuclei?
- 4 If a 1-inch-diameter tumor in a 10-inch-thick patient is irradiated with x-rays, then what fraction of the radiation in the beam is delivered to the tumor?

### ANSWERS

- 1 The lethal radiation dose for people is a whole-body dose. The specified radiation dose for cancer treatment is the dose to tumor. They try to minimize the radiation dose to healthy tissue. An 800-rad whole-body dose will not kill all the cells in the body, but it will kill enough cells so that the body can no longer function. However, when applying radiation to a tumor, doctors want to kill almost all the cancer cells in the tumor and therefore apply doses of around 8000 rads.

- 2 Even though oncologists and medical physicists do their best to maximize the radiation dose to the tumor and minimize the radiation dose to healthy tissue, and even though fast-dividing cancer cells are more susceptible to the effects of radiation than most normal tissue, some healthy tissue still receives large amounts of radiation. This can produce some of the effects of acute radiation syndrome discussed in lecture 5.
- 3 This is because as gas accumulated in the sealed seeds, it would dramatically increase the pressure in the seeds and possibly make them burst, damaging nearby tissue and releasing their contents into the body.
- 4 We can crudely approximate x-rays as delivering about the same amount of energy at all locations in their path (in reality, they deposit more energy at the skin and then progressively less as they go deeper). If the tumor is about 1 inch in diameter and the patient is about 10 inches thick, then about  $\frac{1}{10}$  of the x-ray energy will be delivered to the tumor and the other  $\frac{9}{10}$  (or 90%) will be delivered to healthy tissue. By using many different beams from many different angles, the 90% of energy delivered to healthy tissue will be spread out over as much healthy tissue as possible to reduce the dose delivered to any one spot. However, 90% of the energy of the beam is still deposited in healthy tissue.



## MEDICAL IMAGING: CT, PET, SPECT, AND MRI

**T**he increasingly sophisticated use of radiation has transformed diagnosis and treatment in many fields of medicine with mammograms, PET scans, CT scans, bone-density tests, MRIs, etc. How do they work? What do they reveal? When, if ever, might the doses of radiation be more than might be regarded as acceptable? ◆

## Types of Medical Imaging

- ◆ We measure biological effect in rems or sieverts. The limit for radiation workers is 5 rem per year, or 50 millisieverts. Twenty rem will give someone an extra 1% chance of developing cancer in their lifetime, according to the linear no-threshold hypothesis. Acute radiation syndrome sets in at about 100 rem, or 1 sievert, with symptoms of fatigue and vomiting.
- ◆ Radiation from a single x-ray is between 0.1 and 10 millirem, or between 0.001 and 0.1 millisievert. The medical technician leaves the room when you get an x-ray, but they could stick around for hundreds or thousands of those before hitting their annual dose limit.
- ◆ In reality, the average dose for medical workers is about 300 millirem per year, or 3 millisieverts. They typically get more to their fingers from injecting radioactive materials. This is much less than the 5000-millirem-a-year limit set by the US Department of Energy for radiation workers.
- ◆ Newer types of images are like multiple x-rays: A mammogram is approximately equivalent to 5 chest x-rays, or 1 long airplane flight; a CT scan of the head is like 20 chest x-rays; and a CT scan of the chest is like 100 chest x-rays, or about 20 long airplane flights.

Looking inside the body is like choosing an e-reader: You can either have external illumination, which uses reflected light, or radiation, to see the difference in the reflectivity of ink and paper; or internal illumination, where the screen glows with different colors.



- ◆ In the case of using radiation, there is external illumination—x-rays and CT scans—which shine a beam of radiation on the body and measure the transmitted radiation to see the difference in absorption between bone and tissue. This technique sees structure in the body.

A Harvard report puts a cardiac stress test with nuclear imaging at 40 millisieverts, or 4 rem, which is 80% of the recommended limit for medical workers.

- ◆ There is also internal illumination—PET and SPECT scans—where radiation-emitting substances are injected or inhaled into the body, which transports the molecules. We measure where the radiation is emitted from, which tells us how the molecules are transmitted, and that tells us about function. Here, the radiation dose might be somewhat higher because the nuclide stays in the body after the procedure.

- ◆ Then there is external-ish illumination—**magnetic resonance imaging** (MRI). This used to be called nuclear magnetic resonance, but no ionizing radiation is involved, so the name was changed to not scare people. What MRI sees is mostly structural.

## X-Rays

- ◆ X-rays use x-rays—specifically, they use 50,000- to 150,000-electron-volt x-rays. They take a 2-dimensional picture, measure the differential absorption, and really only see bones and not-bones. That's because calcium has a larger number of protons than most of the other elements in the body, so it absorbs a lot more x-rays. We can also see injected contrast agents, such as barium, in the body. Fortunately, modern cameras are much more sensitive than they used to be, which dramatically reduces the radiation dose needed.

- ◆ To see more, we can take lots of pictures and let the computer figure it out. We rotate the x-ray emitter and the detectors around the body. For each point in the body, we combine the intensities of all the x-rays that pass through that point. The sum depends mostly on the x-ray absorption of the tissue at that point.
- ◆ Then, we use a computer to deconvolute the images to get the absorption of the tissue at each point. We then add it all back together to recreate a 2-dimensional slice of the body. We move the scanner one step along the body and measure another slice. This gives us very high spatial resolution, but we're still just using x-rays, so we only see structure, not function.

## PET and SPECT Scans

- ◆ To image a specific body function, we attach a radioactive isotope to a bioactive molecule. We then watch the uptake of the molecule to trace its function. We track the molecule by the radiation emitted by that radioactive isotope.
- ◆ Alpha and beta particles don't escape the body. Gamma rays can be measured one at a time. A beta-plus particle (positron) travels a short distance in the body, finds an electron, and annihilates to produce 2 back-to-back gamma rays each with exactly 511,000 electron volts. Then, we measure the emitted gamma rays and make an image.
- ◆ For positrons, we want low-energy positrons so that they annihilate quickly. For gamma rays, we want the energy high enough that it can penetrate tissue and leave the body. (This is the opposite need of radiation oncology.) We want the energy low enough that we can see it clearly in a [gamma camera](#), ideally 100,000 to 200,000 electron volts. We want the half-life short enough for high activity that dies away quickly but long enough to use.

- ◆ To detect gamma rays, we use a gamma camera, which uses scintillator crystals and photomultiplier tubes—the “film” for the camera. But there are no lenses to focus gamma rays onto the film to make an image. Therefore, if it’s a PET scan, we have 2 back-to-back gamma rays, and we get the direction by detecting both. If it’s a SPECT scan, which uses 1 gamma ray, then we need a **collimator** in front of each crystal to define the direction.

## GAMMA CAMERA

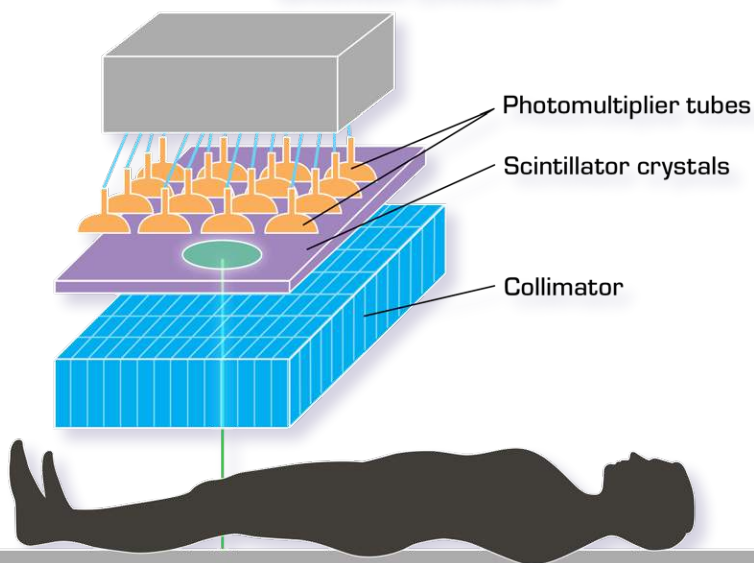

- ◆ We use a lot of crystals and a lot of photomultiplier tubes to cover a large area. The larger the area of the camera, the less radiation is needed. The smaller the crystals that we use, the better the resolution. But the larger the area and the smaller the crystal, the more crystals and photomultiplier tubes we need, which means that the detector costs more.

- ◆ In PET scanning, the positron is emitted and travels a few millimeters, finds an electron, annihilates with it, and produces 2 back-to-back 511,000-electron-volt gamma rays. We have a large ring of detectors to detect both gamma rays at exactly the same time.
- ◆ To reconstruct the PET image, we apply the exact same computing techniques as CT scanning, only using internal illumination instead of external illumination. The typical resolution that we get is about 5 to 10 millimeters, or  $\frac{1}{4}$  of an inch.
- ◆ If there's only 1 photon, then we don't need as large a detector to detect 1 at a time. We use a collimator so that each pixel in the detector only sees the "light" (the gamma rays) coming from 1 direction. A collimator is a thick lead plate with 1 hole in it for each pixel. This gives us a 10% resolution, so if we're looking at something 1 foot away, it gives us a resolution of 1 inch. If it's closer, the resolution is better.
- ◆ The camera gives us a 2-dimensional image. To get a 3-dimensional image, we take pictures from many different angles and combine them. Or we can leave the camera where it is and tilt the collimator, take new images, and then combine them. This is under development at Jefferson Lab. We apply the exact same computing techniques of CT scanning, just like we do for PET scans. SPECT stands for [single-photon emission computed tomography](#).
- ◆ The big advantage of a 3-dimensional image is that we can make slices so that we don't have to see the things in front of or behind the important organ. We can view the organ in different slices at different orientations.
- ◆ To get the isotope to go someplace interesting (a specific organ), we choose the appropriate molecule and attached the isotope to it. For example, radioactive carbon and fluorine have a lot of different biomolecules. Glucose (sugar) is transported to metabolically active

regions, such as the brain or tumors. **Technetium-99** can be attached to a lot of different molecules with different uses; about 85% of SPECT procedures are done with technetium-99.

- ◆ We look at the distribution of radiation that gives us information on the metabolic uptake of the molecule containing the isotope as well as structures in the body. For example, the intensity and imaging of iodine radiation shows the metabolic activity of the thyroid as well as its size and shape.
- ◆ How do we make radioactive isotopes for imaging? PET scans use positron emitters, which are isotopes such as carbon-11, nitrogen-13, oxygen-15, or fluorine-18. They decay by positron emission, which means that they started with too many protons, so we hit a stable nucleus with protons from a cyclotron.
- ◆ These isotopes typically have 2- to 20-minute half-lives. This means that the cyclotron has to be in the hospital so that they don't decay before you can get them to the hospital. This is expensive. Also, because the half-life is so short, we need to do the chemistry very quickly to get the isotopes into those useful molecules. The problem is that this is hot chemistry. These isotopes are radioactive, so we have to do this by remote control.
- ◆ We also make gamma-ray emitters for SPECT, typically in generators with a longer-lifetime isotope that decays to the shorter-lifetime desirable isotope. We want the isotope that we inject to have a relatively short lifetime to reduce the radiation to the patient after the procedure is over. The generator makes it possible to use short-lifetime isotopes.
- ◆ One of the more popular positron emitters is fluorine-18, which is incorporated into a glucose analog called FDG, which is taken up by cells needing energy, such as the brain, tumors, and places where there is inflammation, healing, or muscular activity.

- ◆ The fluorine-18 accumulates in the cells and is seen by the 2 gamma rays it gives off when the positron it emits annihilates with an electron. Using this fluorinated glucose analog lets us image where the brain needs energy (where it's working). Different areas of the brain light up doing different tasks.
- ◆ PET resolution is limited by detector size and positron propagation (how far the positron goes before it annihilates into the photons that we detect). Most of the time, we combine high-resolution structural CT scans with lower-resolution (5- to 10-millimeter) functional PET images to get enough information.
- ◆ How much radiation do patients receive from these scans? In PET and SPECT scans, adults receive about 1 rem, which is equivalent to about 2 to 3 years of background radiation. It corresponds to an increased risk of cancer of about 0.05%, assuming the linear no-threshold hypothesis.
- ◆ Patients become slightly radioactive. With a PET scan, patients emit about 1 millirem per hour at 1 meter away from them immediately after scanning. This decreases very quickly because the half-life is between 2 and 20 minutes.

## MRIs

- ◆ We can image the body without using ionizing radiation with MRI, which images the spins of the hydrogen nuclei (protons) in the body. We use an electromagnet to apply a really large (several tesla) magnetic field to make about 1 in a million of the protons in the body spin-align.
- ◆ The resonant frequency of the protons is proportional to the magnetic field, so we apply a radio-frequency wave at the resonant frequency to rotate the proton spins. The spins are no longer parallel to the magnetic

field. The protons spin-precess at the resonant frequency. The protons emit radio waves at this resonant frequency as they precess, and we detect these radio waves.

- ◆ To make the images, we apply a large magnetic field that points along the patient. We add another parallel field that increases with height. For example, the magnetic field is smaller at the patient's feet and larger at the head. The resonant frequency will now depend on the location along the patient's body. We apply a perpendicular radio-frequency magnetic field at the resonant frequency of the desired slice of the body. This rotates the proton spin around in the selected slice of the patient. Then, we turn off the 2 extra magnetic fields.
- ◆ Next, we turn on another magnet to make a magnetic field that varies along another axis in the slice. The frequency of the radio waves emitted by the precessing protons depends on the distance along that axis. The magnetic field in selects a slice of the slice. We repeat this for different angles and frequencies and deconvolute the data, like we do with a CT scan.
- ◆ MRIs image hydrogen density, which is different in different tissue. For example, the hydrogen density in water is less than it is in fat. We can also see different things, such as how quickly the MRI signal decreases.
- ◆ Functional MRI (fMRI) compares oxygenated (diamagnetic, like normal tissue) and deoxygenated (paramagnetic, which is different) blood. Hemoglobin, despite containing iron, is not ferromagnetic. The more brain or tissue activity, the more oxygen needed for metabolism, the more oxygenated blood, the less local magnetic variation, and the longer the relaxation time.
- ◆ Fortunately, there is a growing panoply of nuclear physics–based tools to look at structure and processes inside our bodies. So, what will come next? There will be better MRI as well as smaller, faster, better gamma cameras.

## Supplements

### READINGS

Christian and Waterstram-Rich, eds., *Nuclear Medicine and PET/CT*.

Gould and Edmonds, “How MRI Works.”

Lilley, *Nuclear Physics*, chap. 9.

National Research Council, *Nuclear Physics*, p. 150–158.

Tilakaratna, “How Magnetic Resonance Imaging Works, Explained Simply.”

### QUESTIONS

- 1 Why does internal radiation (e.g., SPECT or PET scans) show function rather than structure?
- 2 When would a doctor choose to perform a SPECT scan rather than a PET scan (or vice versa)?

### ANSWERS

- 1 This is because the radioactive materials are transported by the body to different locations, and doctors identify those locations by where the radiation is emitted from. Therefore, they are measuring the function of the body in transporting different molecules containing the radioactive isotopes to different locations. For example, technetium-99\* is transported to different locations depending on which biologically active molecule it is attached to.

2 It depends on which body function needs to be imaged and which molecules are available. Radioactive isotopes for PET scans have half-lives measured in minutes or tens of minutes. PET scans are limited to molecules that can be very rapidly synthesized that contain carbon, oxygen, or fluorine. In practice, most PET scans are done with FDG, a glucose analog containing radioactive fluorine. Because the half-life is so short, the radioactivity of the patient decreases to almost zero within a few hours. SPECT scans can use a wider range of radioactive isotopes and molecules. In practice, about 80% of SPECT scans use technetium-99\* in a remarkably wide variety of molecules. Technetium-99\* has a 6-hour half-life, so there is more time to perform the necessary hot chemistry to incorporate the technetium-99\* into the appropriate molecule. On the other hand, it takes a few days for the patient's radioactivity to decrease to almost zero.



# 23

## ISOTOPES AS CLOCKS AND FINGERPRINTS

Isotopes with unstable nuclei are like clocks and fingerprints, which we use to date and identify many features of our world. We can use carbon-14 analysis to date both archeological findings and the vanilla in your kitchen. In the first case, we measure the age of an unknown object to learn more about it. In the second case, we measure the “age” of a known object to look for fraud. In this lecture, you will discover the many things that can be learned from measuring isotopes. ◆

---

## How do we date objects using radioactive decay?

We choose an object that stopped replenishing its supply of a certain element at a certain time, such as death for animals and plants, chemical formation for rocks, and separation from the atmosphere for water. These radioactive isotopes come from either the uranium, thorium, or potassium decay chains or from cosmic-ray interactions in the atmosphere.

We choose an isotope with an appropriate half-life and appropriate chemistry. If we want to date really old rocks, then we use uranium, with a half-life of billions of years. If we want to date groundwater, we use krypton-81, with a half-life of 230,000 years. If we want to date organic material, we use carbon-14, with a half-life of almost 5700 years.

---

### Carbon Dating

- ♦ Carbon is absorbed by all living organisms. Hydrogen, nitrogen, and oxygen are also absorbed, but they don't have any convenient isotopes. The unstable isotope of hydrogen, tritium, has a half-life of 12 years, and the unstable isotopes of nitrogen and oxygen have half-lives that are less than 5 minutes.
- ♦ Carbon-14 has a 5700-year half-life, which is well matched to archeological times. We can date objects back to about 10 times the half-life, or about 60,000 years. This technique was developed by Willard Libby in the 1940s; he received the Nobel Prize in Chemistry for this in 1960.

- ◆ Carbon-14 is continuously created in the atmosphere by cosmic rays, which are high-energy charged particles coming in from outer space, interacting with the nuclei in our atmosphere, and, in this case, transmuting nitrogen-14 to carbon-14. Carbon-14 is only 1 part per trillion of the carbon in our atmosphere, so it's not enough to give us significant radioactivity, but it is enough to measure.
- ◆ If we want to date a sample of carbon, then we count the radiation given off by the carbon-14 decay. To get 99% accuracy, we need to count 10,000 decays. We need 4 grams of carbon, which is actually a big sample of a precious, unique archeological artifact. That might be an entire page from a rare manuscript or a very large swatch of ancient cloth.
- ◆ We can use smaller samples, but we don't wait for the atoms to decay. We put a tiny sample in an [accelerator mass spectrometer](#) and count the atoms. The accelerator mass spectrometer will separate the carbon-12 from the carbon-13 from the carbon-14, and we can count the relative numbers of atoms.
- ◆ Using this technique, we can use milligram or microgram samples—samples that are 1000 or 1 million times smaller than an entire page of an ancient manuscript. This technique has a sensitivity of 1 part in  $10^{15}$ , or 1 part per quadrillion, and the spectrometers that we use are relatively small and compact.
- ◆ Anything organic (in the chemical sense of organic, which means it contains carbon) can be dated—including the medieval manuscripts in the library at the University of Seville, the Shroud of Turin (a length of linen cloth bearing the alleged image of Jesus that some believed was Jesus's burial shroud but was dated to between 1260 and 1390, not the time of Jesus), and the Artemidorus papyrus (which some people thought was a 19<sup>th</sup>-century forgery but was dated to about 1900 to 2000 years before the present).

- ◆ When we do **carbon dating**, we date based on the decay of carbon, but then we have to calibrate it because the abundance of carbon-14 in the atmosphere varies slightly over time. This is because of 2 effects. First, the cosmic-ray rate in the atmosphere (which makes carbon-14) varies. Second, volcanoes and modern industrial activity emit old carbon dioxide (that has no carbon-14 left) into the atmosphere that dilute the carbon-14 in the atmosphere.
- ◆ To calibrate the date, we measure samples of a known age—from other dating methods, such as tree rings—to make the calibration curve. We just need the calibration curve for 1 sample of a particular date and then we know how to calibrate things at that date. We use the calibration curve to convert the carbon-14 date to a real date.

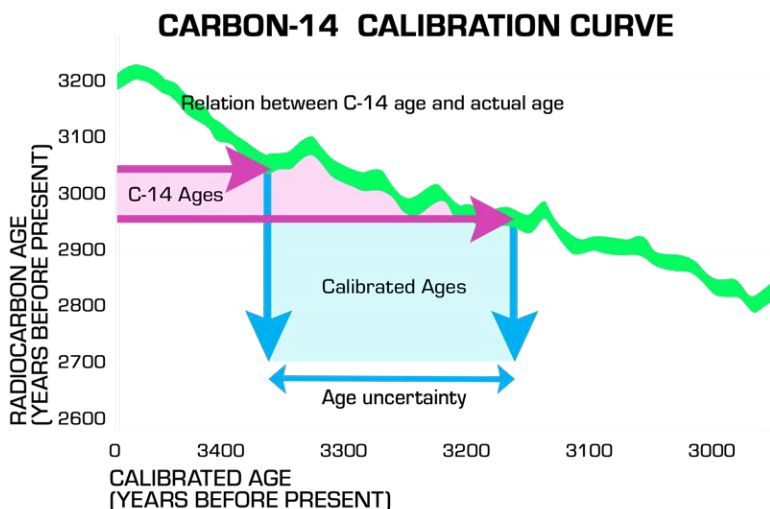

- ◆ Establishing 3000-year-old dates, such as the Megiddo archeological site in Israel, is particularly tricky due to wiggles in the calibration curve at that time. The calibration curve gives a 200-year range of reconstructed dates, which is a long time for a historical site.

- ◆ How do bomb tests affect carbon dating? The carbon-14 concentration doubled from 1955 to 1963 due to bomb tests. This is called the **bomb peak**. The concentration of carbon-14 then decreased as carbon was exchanged between the atmosphere and the oceans. It's still slightly above normal.

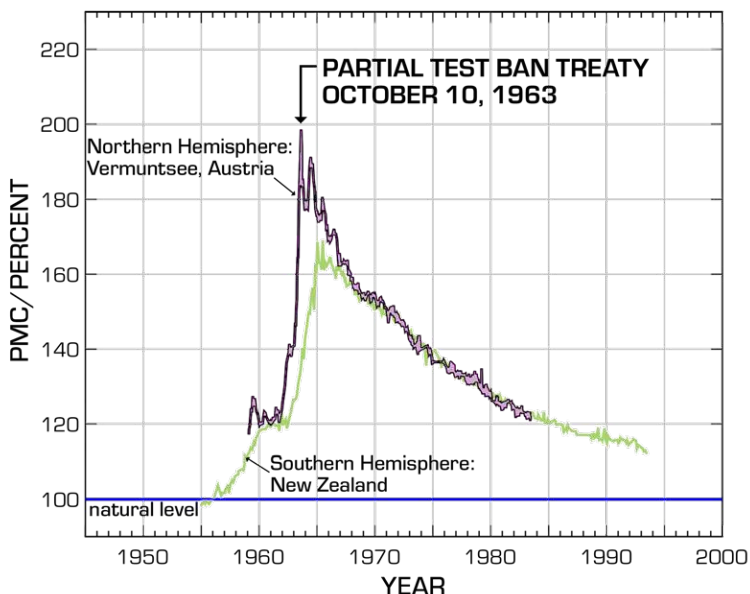

- ◆ We can use this information to precisely date post-1955 objects, and we can detect modern forgeries of pre-1955 objects. For example, a painting by Fernand Léger was supposedly painted in 1913 or 1914 was in the Peggy Guggenheim collection, but carbon dating showed that the painting had 30% too much carbon-14, so it had to have been made after 1955 and was a modern forgery.

By testing the carbon-14 levels in sparkling wine, we can tell the difference between natural fermentation (with carbon-14) and artificial carbonation (carbon dioxide from fossil fuel burning, which has no carbon-14).



- ◆ We can also use carbon dating to date expensive wines; to date modern animal parts, such as elephant tusks, to determine if they were harvested before or after certain laws were enacted; and for neurological research, such as to determine when individual neurons were created and whether the brain continues to make new neurons.
- ◆ Why should we carbon-date food? Real food products come from plants and should have modern carbon-14 abundances. Artificial products are synthesized from chemical feedstocks derived from fossil fuels and have no carbon-14.
- ◆ Because food products are not precious items and there are no limits on sample size, we can burn the sample to reduce the carbon to carbon dioxide. Then, we can convert the carbon dioxide to methane, include the sample gas in a wire chamber, and count the carbon-14 decays.
- ◆ Alternatively, we can convert the carbon dioxide to benzene, include it in a liquid scintillation counter, and count the decays. These detectors are just like the ones used at Jefferson Lab for nuclear physics experiments. Modern material counts about 15 disintegrations per minute for each gram of carbon.



Vanilla is an expensive natural flavoring, and it has the standard ratio of carbon-14 that is in the atmosphere. Vanillin, the primary component of vanilla, can be synthesized using chemical feedstocks, typically derived from natural gas, that does not contain carbon-14.

Early testing showed no carbon-14 in many vanillas that were being sold as natural. Forgers now synthesize vanillin from carbon-14 and add it to samples. In other words, they are adding radiation (albeit a negligible amount) to our food to make it look natural.

## Other Types of Dating

- ♦ Carbon-14 dating won't work for inorganic or very old objects, so we have to use other tools. For example, if we want to date really old rocks, they have no carbon and are too old, so we typically use either uranium or potassium-40. Both of these have very long half-lives; which one we choose depends on the kind of rock that we want to date.
- ♦ If we want to date groundwater or deep ocean currents, then we could use carbon, but the problem is that carbon is chemically active, so it won't stay put. Instead, we use radioactive isotopes of inert gases. There are no useful isotopes of helium or neon; their half-lives are too short. Instead, we use argon-39, which has a half-life of 269 years, for ocean currents, and we use krypton-81, with a half-life of 230,000 years for groundwater.

- ◆ We can do uranium-lead dating. Uranium-238 has a half-life of 4.5 billion years; there is a long decay chain that ends up with lead-206. Uranium-235 has a half-life that is about 6 times shorter, 710 million years, and its long decay chain ends up at lead-207. The ratio of how much lead is in the rock to how much uranium is in the rock for those different isotopes gives us ages. But we don't know the initial concentration of uranium, so we use both the uranium-238 to lead-206 ratio and the uranium-235 to lead-207 ratio to correct for loss of lead due to leaching out of the mineral. We want to choose a mineral to date that has uranium in it but no lead, such as zircon, which is used to date rock formations up to the age of the Earth.
- ◆ We can do potassium-argon dating. Potassium-40 decays to argon-40 with a half-life of 1.25 billion years. Argon-40 is stable (in fact, that's where the argon-40 in our atmosphere comes from). The argon that results from potassium decay is trapped in the rock matrix. The ratio of the argon-40 to the potassium-40 gives us the age of the rock. It measures when the rock last solidified because when the rock is molten, the argon can escape.
- ◆ We can also do krypton-81 dating of groundwater. Krypton-81 is produced in the upper atmosphere by cosmic rays hitting stable krypton isotopes. This is similar to how carbon-14 is produced. The half-life of krypton is 230,000 years. Krypton is inert—it doesn't react—so it's ideal for tracing water. But it's difficult to measure. Like carbon-14, the concentration is in parts per trillion, but it has very low solubility. There are only about 2000 krypton atoms in a liter of water.
- ◆ We now use a more sensitive technique, called atom trace trap analysis, which involves laser manipulation of individual atoms to count them. We extract the krypton from several tons of groundwater. One application of this technique is to date old ice from ice cores, which helps us establish dates for global temperature records.

- ◆ Deep ocean water circulation takes about 1000 years and is crucial for global heat transport. Krypton has too long a half-life, so we use argon-39 to measure the age of water samples. Just like krypton and carbon-14, argon-39 is produced in the atmosphere by cosmic rays interacting with stable argon-40 to make argon-39, which has a half-life of 269 years. The concentration, unfortunately, is 1 part in  $10^{15}$ , or 1 part per quadrillion. The amount of argon-39 remaining tells us how long that water was flowing at the bottom of the ocean.
- ◆ Ionizing radiation creates defects (electrons and holes) in mineral crystal grains in ceramics or rock. These defects accumulate over time. They can be erased by baking or exposure to sunlight. We measure the time since the object was last baked (over 500 centigrade), which applies to ceramics and glasses, or we measure the time since the object was last exposed to sunlight, which applies to glasses, sediment layers, and old streets.
- ◆ How do we measure this damage? Heating the material lets the electrons and holes recombine and emit light, and we measure the thermoluminescence. Or we can expose the sample to specific wavelengths of light and measure the optically stimulated luminescence, and the amount of light given off (the luminescence) is proportional to the age of the sample. This is called **luminescence dating**.
- ◆ Then, we determine the yearly radiation dose by burying standard test pellets for a year and measuring the nearby radioactive isotopes. By applying these techniques, we can study the age of quartz strains sensitive up to about 300,000 years. There is a wide range of applications of this, including dating bricks in the Saint James Church in Torún, Poland, and dating strata at Megiddo.

- ◆ Unstable isotopes let us date objects. What can we learn from stable isotopes? There are 2 main different photosynthetic paths in plants (called C3 and C4), giving 2 slightly different ratios of carbon-13 to carbon-12. We measure the carbon-13 to carbon-12 ratio by burning it to carbon dioxide, putting it in a mass spectrometer, and comparing masses 44, 45, and 46. If it's carbon-12 and oxygen-16, it has a mass of 44; if it's carbon-13 and oxygen-16, it has a mass of 45.
- ◆ Using this information, we can look for corn syrup (path C4) adulteration in products from plants that use path C3, such as honey, maple syrup, and fruit juice. Corn syrup is much cheaper, so it's a lot cheaper to adulterate and replace some of these with corn syrup.
- ◆ What other isotopes can we learn from? Heavy water (deuterium oxide or hydrogen plus oxygen-18) evaporates slightly less than regular water. The abundance of heavy water decreases as you go from the equator north or from the equator south. Heavy water has gone through more evaporation cycles and is colder. One way to use this information is to measure the average global temperature from heavy-water concentration in Greenland ice cores because the evaporation rate of heavy water depends on temperature.
- ◆ We can use isotopic abundances both to determine the date of an object and its source. These radioactive isotopes need to be either from the uranium, thorium, or potassium decay chains in the Earth or made in the atmosphere by cosmic rays, such as carbon, argon, or krypton. The effects and uses of these isotopes are opportunities to explore—for chemists, geologists, archeologists, biologists, and everyone else.

## Supplements

### READINGS

Arnold, “Cold War Bomb Testing Is Solving Biology’s Biggest Mysteries.”

Collon, “Using Nuclear Techniques to Analyze Art.”

Lilley, *Nuclear Physics*, chap. 8.

Mackova, et al., eds., *Nuclear Physics for Cultural Heritage*.

### QUESTIONS

- 1 Could someone have used carbon-14 dating to prove that the 1983 Hitler Diaries, which were sold for more than 9 million deutsche marks, were forgeries?
- 2 How much radioactive material would a forger need to add to artificial vanilla so that it has the same carbon-14 content as natural vanilla?
- 3 Why can't we use carbon-14 dissolved in water to date groundwater or ocean water, rather than using argon or krypton?

## ANSWERS

- 1 Probably. Analysis of the paper would probably have shown that it had too high a content of carbon-14 and had been made after the 1950s bomb pulse.
- 2 Because the abundance of carbon-14 is only 1 part per trillion, 1 teaspoon of vanilla (about 5 grams) would need at most 5 picograms (5 trillionths of a gram) of carbon-14. This is about  $5 \times 10^{10}$  carbon-14 atoms. Carbon-14 has a half-life of about 6000 years, or  $2 \times 10^{11}$  seconds. Therefore, one of the  $5 \times 10^{10}$  carbon-14 atoms would decay about once every 4 seconds. Thus, the forgers would need to add  $\frac{1}{4}$  becquerels of carbon-14 to each teaspoon of vanilla. This is much less than a banana equivalent dose.
- 3 This is because carbon is chemically and biologically active and therefore will not stay put. The argon or krypton could only enter the water when it was in contact with the air. Carbon could enter the water through chemical reactions or biological transport (e.g., fish excreta).



# 24

## VIEWING THE WORLD WITH RADIATION

**M**easuring radiation, either emitted by an object or passing through it, gives us a new way to look at the world. There are many options with radiation. We can do passive scanning, where we look for radioactive materials; we measure gamma rays and maybe neutrons, but we don't measure alpha and beta particles because they don't escape to be detected. We can also do active scanning, such as measuring absorption or scattering in materials with lots of protons using x-rays or CT scans, exciting radioactivity using x-rays or gamma rays, doing surface scans with **x-ray fluorescence**, and scanning the volume of an object using **nuclear resonance fluorescence** or **neutron activation analysis**. Furthermore, we can use **radioactive tracers**, just like we do in nuclear medicine. ◆

## Passive Scanning

- ◆ Passive scanning means looking for the radiation emitted by an object. For example, we look for radioactive material in scrap metal going to steel mills. Radioactive steel was made into reinforcement bars for apartment buildings in Taiwan in the early 1980s. Those apartments are still slightly radioactive.
- ◆ We can detect nuclear tests. In 1945, the Kodak company received lots of complaints that their x-ray film was fogged. Kodak was careful to avoid radium contamination of the packaging for their film. But they traced the fogging to packaging made in Indiana that was contaminated with nuclear fallout from the Trinity test.
- ◆ In 2006, we detected radioactive xenon-133 two weeks after a North Korean nuclear bomb test. The test was underground, but it's very difficult to keep noble gases like xenon from escaping the test site, even underground. There is a worldwide network of monitoring sites that look for isotopes like xenon to detect nuclear bomb tests.
- ◆ What else can we learn about nuclear tests or explosions? If we can sample the ground where the test took place, the distribution of **actinides** (such as uranium and plutonium) tells us whether it was a uranium bomb or a plutonium bomb. We can figure out the grade of fuel if it was a plutonium bomb from the ratio of plutonium-240 to plutonium-239. We can tell whether it was bomb grade or just reactor grade from the ratio of uranium-235 to uranium-238. We can see how enriched the uranium was. And we can determine the age of the plutonium in the device from the ratio of other isotopes, americium-241 to plutonium-241.

Why would anyone want to put a nuclear physics experiment in a 1-foot hole, miles underground, right behind a drill bit? The environment is incredibly hostile, with high temperature, high pressure, and lots of vibration and abrasion. This is done to study the surrounding rock to look for oil and gas.

---

Cobalt-60 from a medical source contaminated a truck in Mexico in 1983. When the truck was scrapped and recycled, the cobalt contaminated 5000 tons of steel. This was discovered when a load of that steel entered Los Alamos National Laboratory and set off the radiation alarms.

---

- ◆ What material was used? Did they use a deuterium-tritium boost? To determine this, we don't need to be on the ground; instead, we can fly through the fallout plume and sample the gases. Then, we take ratios of isotopes because lots of background and noise cancel in ratios. We look at the ratio of iodine-130 to iodine-135 versus cesium-136 to cesium-137. This tells us whether it was a uranium bomb or a plutonium bomb and by how much the yield was boosted by fusion boosting.

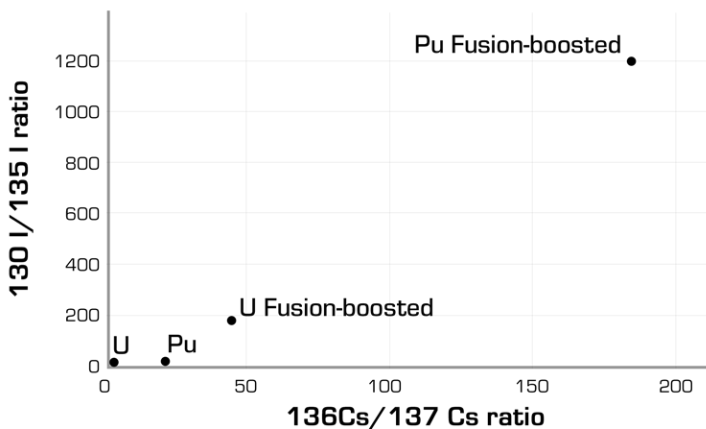

- ◆ How do we detect smuggling of radioactive materials for a bomb or a dirty bomb? We have **radiation portal monitors** at places where lots of material enters the United States. We usually have radiation monitors for gamma rays and sometimes for neutrons. We use plastic scintillators (which are relatively cheap detectors) for screening. If we see radiation, then we measure the gamma-ray energies more precisely with higher-resolution crystal scintillators, such as sodium iodide or high-purity germanium.
- ◆ We can also use neutron detectors that use helium-3 and take advantage of the reaction that if a neutron hits helium-3, it can make helium-4 and give off a gamma ray. Medical patients and truckloads of bananas set off alarms. Uranium and plutonium are not very radioactive—they don't emit many gamma rays—so they're very difficult to detect passively.
- ◆ We can also use natural radiation (cosmic-ray muons) to scan objects. About 1 cosmic ray passes through your hand every second. These are high-energy muons, of several billion electron volts, so they're very penetrating. We can put detectors below the objects to see if we have more muons in one place than in another, and if that is the case, then they pass through more mass in one place than another. This was used to detect hidden chambers in the second pyramid of Giza.
- ◆ Alternatively, we can put muon detectors above and below the object to measure where muons change direction, or scatter. From this information, we can make a density map of the object or, for example, we could see where the high-atomic-number materials (uranium and plutonium) are in trucks. One application of this has been to measure the inner structure of the dome of the Santa Maria del Fiore in Florence to look for possible iron reinforcing chains that helped hold it together.

## Active Scanning

- ◆ We can learn much more if we can actively scan with a beam that we control. For example, we can use x-rays to measure x-ray absorption and measure the density profiles of materials (especially those with lots of protons). One application is looking for weld defects when 2 pieces of metal are welded together.
- ◆ We can go beyond density and measure what something is made of by using a few different techniques. X-ray fluorescence involves exposing a target to x-rays from 20 to 60 kilovolts and then looking for lower-energy x-rays emitted by the target. Because x-rays have very limited range, this technique only measures materials on the surface. The different x-ray energies are characteristic of different elements.

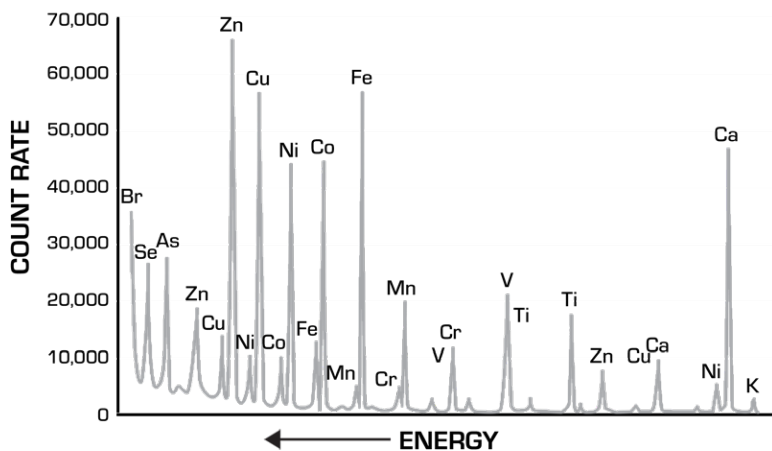

- ◆ In 2011, 53 paintings sold in Germany that were allegedly by 20<sup>th</sup> century masters were determined to be forgeries. This was \$30 million in art sales. One painting, allegedly by Max Ernst, sold for more than \$1 million. The authenticator swore that it was genuine Max Ernst and didn't need scientific testing. But x-ray fluorescence showed titanium, which was not used in contemporary pigments, so it had to be a forgery.
- ◆ Another technique is **ion beam analysis**, which involves measuring the same characteristic x-rays but exciting them with low-energy (of a few million electron volts) ion or proton beams that hit the sample. This uses a relatively small accelerator. Similar to x-ray fluorescence, this technique is sensitive to the surface of the material, but the advantage of this over x-ray fluorescence is that the beam energy allows us to select the depth of analysis (on the order of micrometers).
- ◆ From ion beam analysis, we can learn the composition of gilding in late antiquity jewelry, the source of alkali in early medieval glass beads, whether the death of Tycho Brahe was due to mercury poisoning (it probably wasn't), and the date of Galileo's writings by analyzing the ink he used.
- ◆ Curiosity and Sojourner Mars rovers carried alpha-particle x-ray spectrometers to measure the composition of the Martian soil. If we increase the photon energy from x-rays to gamma rays, we can excite the nuclei, not just atomic electrons. One big advantage of this technique—called nuclear resonance fluorescence—is that gamma rays can travel much greater distances.
- ◆ We use a 6- to 10-million-electron-volt linear accelerator to make photons that range from zero up to 6 to 10 million electron volts. These photons are usually called gamma rays but are sometimes sloppily called x-rays. The photons at resonant energies excite narrow nuclear states. The nucleus deexcites by emitting a very specific photon energy. We measure the photon energies to determine the elemental composition of the sample.

- ◆ We can combine nuclear resonance fluorescence with other nuclear techniques to scan cargo containers. We need to scan quickly—1 or 2 minutes per container—and not use much radiation because we don't want to harm the contents or any possible stowaways.
- ◆ Another way to study the composition of objects nondestructively is through neutron activation analysis, which involves bombarding a sample with neutrons, typically either from a reactor, a spallation source, or a radioactive source. The slower neutrons have a higher interaction probability.
- ◆ The atom absorbs the neutron, now in an excited state, so it emits a prompt gamma ray to deexcite. The gamma-ray energy depends on the neutron energy and the nuclear binding. Some nuclei are now unstable, so they decay and emit delayed photons.

A company called Passport Systems uses a 9-million-volt linear accelerator to scan a pencil beam of high-energy photons across a cargo container and measure everything that can be measured—absorption of transmitted photons or x-rays and backscattered photons—to give a 3-dimensional density profile of the high-atomic-number material in the container. Then, nuclear resonant fluorescence is used to measure the photons reemitted at lower energies, which allows the identification of specific elements. A system like this can detect alcohol from the ratio of carbon to oxygen; explosives from the ratios of carbon, oxygen, and nitrogen; and special nuclear materials from density and from emitted neutrons.

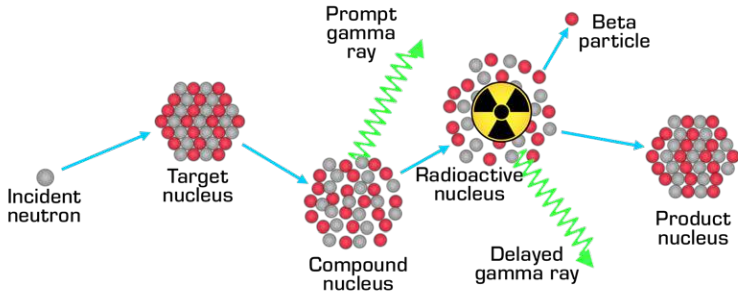

- ◆ The benefit of neutron activation analysis is that the neutrons penetrate the entire volume of the sample, so we can measure the overall composition of the object. With this technique, we're not just looking at the surface.
- ◆ Because all elements emit prompt gamma rays, we only see the major components of the sample. The signal from trace elements is overwhelmed. But only some elements emit delayed gamma rays. They have different half-lives and characteristic gamma-ray energies; therefore, this measurement is much more sensitive to lower concentrations of elements.

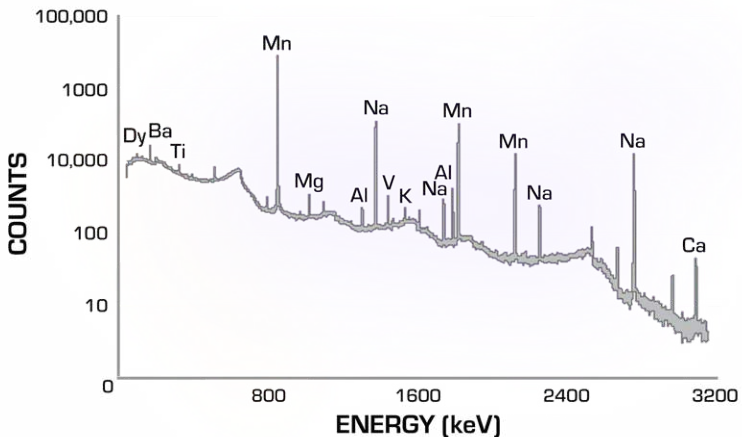

- ◆ Specific gamma-ray energies (spectral lines) correspond to specific elements. Therefore, in a particular sample, we might see the biggest peaks from manganese and sodium and much smaller peaks from titanium and magnesium, meaning that there are just trace amounts of those elements.

The Fermi Gamma-Ray Space Telescope detected gamma-ray pulsars and gamma-ray bursts with 10,000 times the power of a supernova.

- ◆ Using neutron activation analysis, archeologists have discovered sources for Mayan obsidian that was found at Chichén Itzá, which tells us about neolithic trade patterns in Central America. Archeologists have also measured the silver content of Roman coins with prompt neutron activation analysis to see which coins were debased by which emperors. They found that the silver content of the Roman coins decreased particularly rapidly during times of political instability.

## Radioactive Tracers

- ◆ In addition to active and passive scanning, we can use radioactive tracers. This is just like what we do in nuclear medicine with technetium or PET scanning.
- ◆ One application is radioactive tracers of different plant nutrients. We can add the appropriate isotopes either to the plant fertilizer to see how it takes up the fertilizer or to the atmosphere to see how it absorbs carbon dioxide. Then, we can measure the radiation given off by the tracers with PET or SPECT scanning.

- ◆ For example, how do plants react to higher carbon dioxide concentrations? We can add carbon dioxide made with carbon-11 to the atmosphere and measure carbon uptake as we vary the carbon dioxide levels, or the nutrient levels, etc.
- ◆ We can measure radiation given off in the leaves or stems, but the roots are underground. How do we measure the root system? A rhizobeta detector, which is under development at Jefferson Lab, uses lots of plastic scintillator balls connected by wavelength-shifting fibers. The signals are measured with photomultiplier tubes, and as a result, we know where the radiation was detected.
- ◆ Very few photomultiplier tubes are used, so we can cover a large area relatively inexpensively. A detector buried around the roots of plants can tell us, for example, how plants absorb nutrients by measuring the electrons given off by phosphorous-32 and phosphorus-33 beta decay. We can use the same detector to potentially measure radiation leaks in groundwater from nuclear sites.

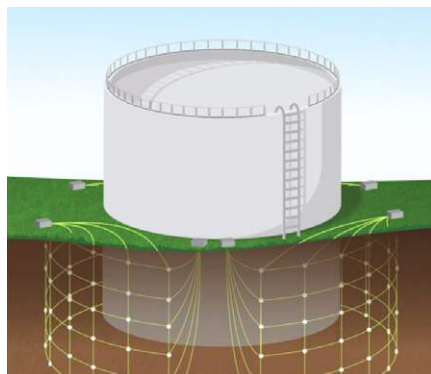
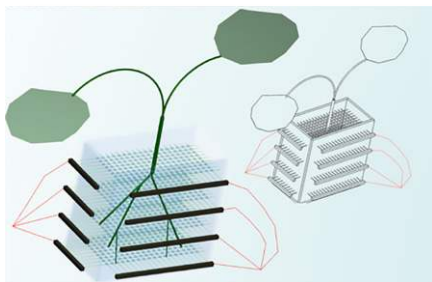

## Supplements

### READINGS

Baras, “Exploding Stars Could Have Kick-Started Our Ancestor’s Evolution.”

Blitz, “When Kodak Accidentally Discovered A-Bomb Testing.”

Collon, “Using Nuclear Techniques to Analyze Art.”

Glascoock, “Overview of Neutron Activation Analysis.”

Lilley, *Nuclear Physics*, chap. 8.

Mackova, et al., eds., *Nuclear Physics for Cultural Heritage*.

### QUESTIONS

- 1 What technique could we use to determine if a wedding ring was solid gold or just gold plated?
- 2 How does the half-life of PET isotopes limit PET studies of carbon uptake by plants?
- 3 Why don’t we use neutron activation analysis to scan cargo containers for special nuclear material?

### ANSWERS

- 1 We would need to use a technique that is sensitive to the entire volume of the object, not just its surface. We could use neutron activation analysis and detect the prompt gamma rays emitted by the material of the ring to see its major components.

- 2 Carbon-11 has a half-life of 20 minutes, so PET studies can only look at the immediate uptake of carbon from the atmosphere, rather than the transport of carbon within the plant.
- 3 Cost, speed, and resolution. We can make a narrow, intense beam of gamma rays for nuclear resonance fluorescence measurements with a relatively inexpensive compact electron accelerator. We cannot make a narrow, intense beam of neutrons. A wider beam would have much worse spatial resolution.



# THE PERIODIC TABLE OF THE ELEMENTS

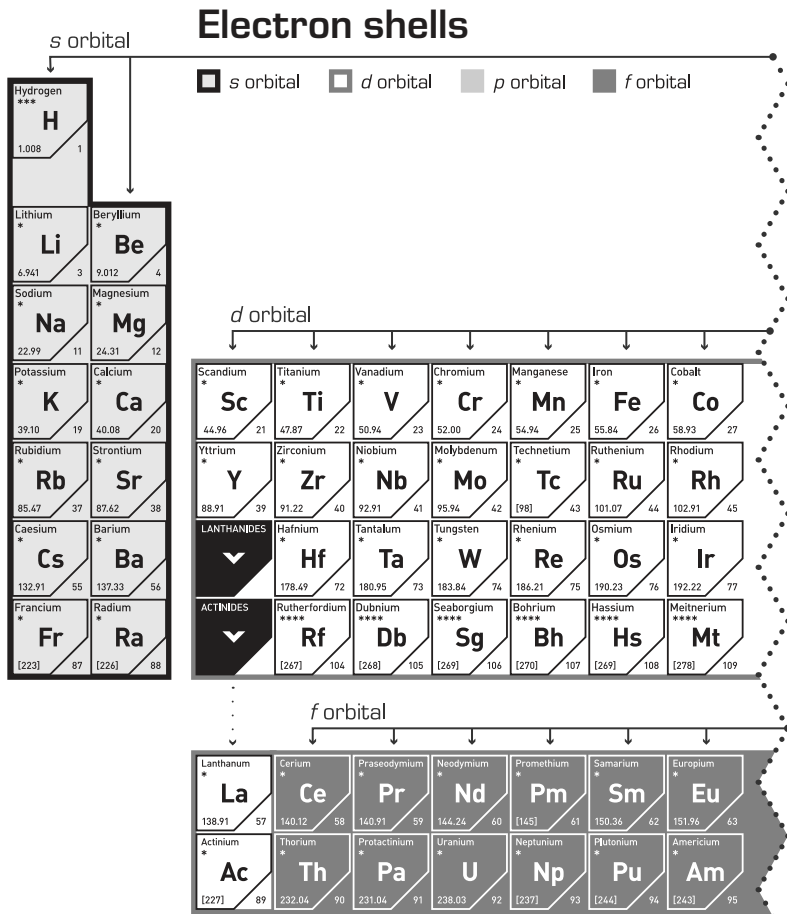

Xenon  
\*\*\*  
**Xe**  
131.29      54

— Name of element  
— Element state  
— Chemical symbol  
— Atomic weight  
— Atomic number

- \* Solid
- \*\* Liquid
- \*\*\* Gas
- \*\*\*\* Unknown
- Noble gas

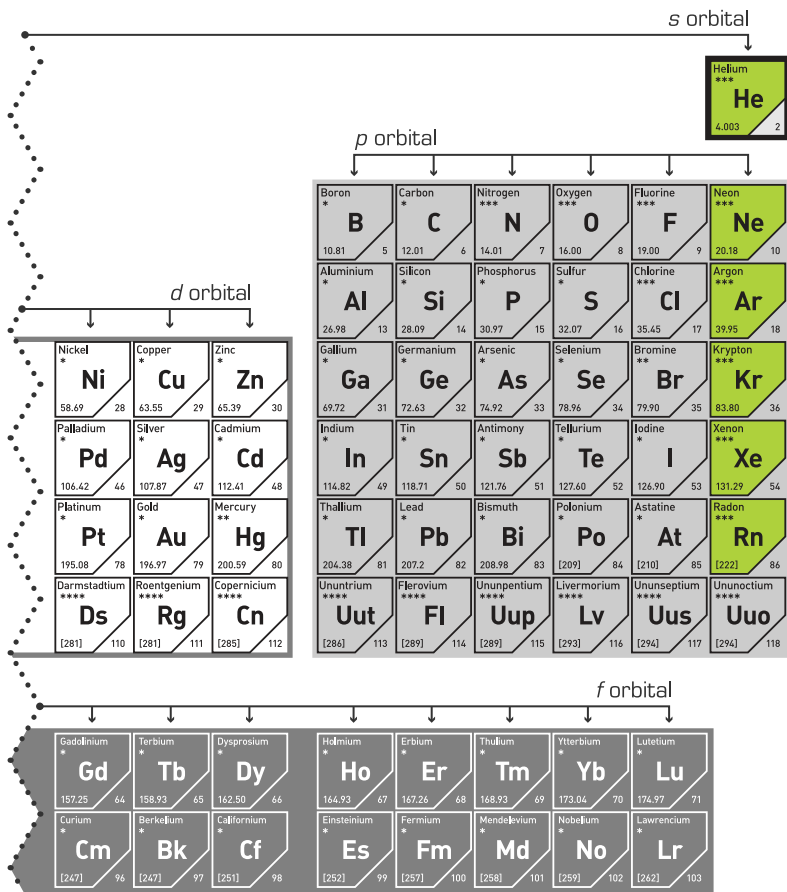

# ...CONTINUED

## Proton shells

<b>1s</b>
1

<b>1p</b>	<b>1p</b>
3	4
<b>1d</b>	<b>1d</b>
11	12
<b>1d</b>	<b>1d</b>
19	20
<b>1f</b>	<b>1f</b>
37	38
<b>2d</b>	<b>2d</b>
55	56
<b>2f</b>	<b>2f</b>
87	88

<b>1f</b>	<b>1f</b>	<b>1f</b>	<b>1f</b>	<b>1f</b>	<b>1f</b>	<b>1f</b>
21	22	23	24	25	26	27
<b>2p</b>	<b>2p</b>	<b>1g</b>	<b>1g</b>	<b>1g</b>	<b>1g</b>	<b>1g</b>
39	40	41	42	43	44	45
LANTHANIDES ▼	<b>1h</b>	<b>1h</b>	<b>1h</b>	<b>1h</b>	<b>1h</b>	<b>1h</b>
	72	73	74	75	76	77
ACTINIDES ▼	<b>3p</b>	<b>1i</b>	<b>1i</b>	<b>1i</b>	<b>1i</b>	<b>1i</b>
	104	105	106	107	108	109

<b>1g</b>	<b>1g</b>	<b>1g</b>	<b>1g</b>	<b>1g</b>	<b>1g</b>	<b>1g</b>
57	58	59	60	61	62	63
<b>2f</b>	<b>2f</b>	<b>1h</b>	<b>1h</b>	<b>1h</b>	<b>1h</b>	<b>1h</b>
89	90	91	92	93	94	95

**1s**  
2



<b>1f</b> 28	<b>2p</b> 29	<b>2p</b> 30
<b>1g</b> 44	<b>1g</b> 47	<b>1g</b> 48
<b>1h</b> 78	<b>2d</b> 79	<b>2d</b> 80
<b>1i</b> 110	<b>1i</b> 111	<b>1i</b> 112

<b>1p</b> 5	<b>1p</b> 6	<b>1p</b> 7	<b>1p</b> 8	<b>1d</b> 9	<b>1d</b> 10
<b>1d</b> 13	<b>1d</b> 14	<b>2s</b> 15	<b>2s</b> 16	<b>1d</b> 17	<b>1d</b> 18
<b>2p</b> 31	<b>2p</b> 32	<b>1f</b> 33	<b>1f</b> 34	<b>1f</b> 35	<b>1f</b> 36
<b>1g</b> 49	<b>1g</b> 50	<b>2d</b> 51	<b>2d</b> 52	<b>2d</b> 53	<b>2d</b> 54
<b>2d</b> 81	<b>2d</b> 82	<b>2f</b> 83	<b>2f</b> 84	<b>2f</b> 85	<b>2f</b> 86
<b>1i</b> 113	<b>1i</b> 114	<b>1i</b> 115	<b>1i</b> 116	<b>1i</b> 117	<b>1i</b> 118

<b>1g</b> 64	<b>3s</b> 65	<b>3s</b> 66
<b>1h</b> 96	<b>1h</b> 97	<b>1h</b> 98

<b>1h</b> 67	<b>1h</b> 68	<b>1h</b> 69	<b>1h</b> 70	<b>1h</b> 71
<b>1h</b> 99	<b>1h</b> 100	<b>3p</b> 101	<b>3p</b> 102	<b>3p</b> 103

# THE CHART OF NUCLIDES

Visit <https://www.nndc.bnl.gov/chart/> to see a comprehensive and interactive chart of nuclides.

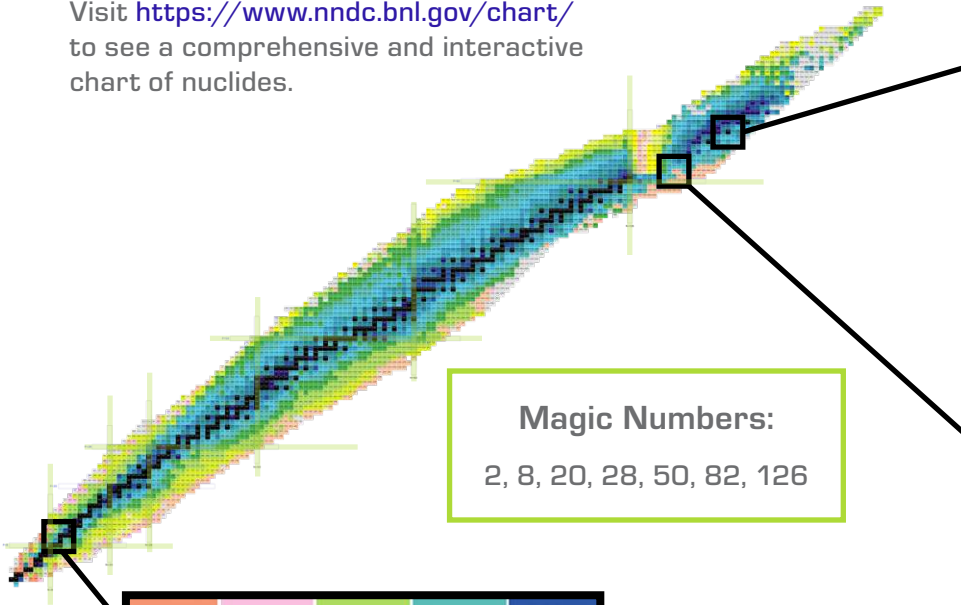

**Magic Numbers:**  
2, 8, 20, 28, 50, 82, 126

18Na	19Na	20Na	21Na	22Na
17Ne	18Ne	19Ne	20Ne	21Ne
16F	17F	18F	19F	20F
15O	16O	17O	18O	19O
14N	15N	16N	17N	18N

238Pu	239Pu	240Pu	241Pu	242Pu
237Np	238Np	239Np	240Np	241Np
236U	237U	238U	239U	240U
235Pa	236Pa	237Pa	238Pa	239Pa
234Th	235Th	236Th	237Th	238Th

222Ra	223Ra	224Ra	225Ra	226Ra
221Fr	222Fr	223Fr	224Fr	225Fr
220Rn	221Rn	222Rn	223Rn	224Rn
219At	220At	221At	222At	223At
218Po	219Po	220Po	221Po	222Po

# GLOSSARY

---

## A

**abundance:** The fraction of an element comprised by a given isotope of that element. For example, carbon-12 comprises 98.93% of naturally occurring carbon, so its abundance is 98.93%. By contrast, the abundance of uranium-235 is only 0.72%.

**accelerating cavity:** Uses metal shaped into resonant cavities that build up electromagnetic fields (usually microwave or radio wave frequency) whose polarity is reversed many times each second in time with the arrival of charged particles so as to push and pull the charged particles along, accelerating the particles almost to the speed of light. Often made from superconducting material to reduce power used and heat dissipated in the cavity.

**accelerator:** Device that uses an electric field to speed up charged particles to high energies. This includes an electrostatic generator, such as a Van de Graaff generator, which accelerates the charged particles through a large constant (DC) voltage; and a radio-frequency accelerator, such as a [linear accelerator](#) or a [cyclotron](#), which accelerates groups of particles (pulses) that are synchronized with the frequency of the radio waves.

**accelerator mass spectrometer:** A very sensitive [mass spectrometer](#) that can measure the masses of individual atoms. Used for [carbon dating](#) and other forms of radioactive dating because it only needs tiny samples of the material.

**acceptance:** Used to describe the [spectrometers](#) that detect the particles knocked out from reactions at accelerator labs. Large-acceptance spectrometers can typically detect particles emitted at almost all angles and momenta from the collision, while small acceptance spectrometers can typically only detect particles emitted in a very small range of angles and momenta. Jefferson Lab (Newport News, Virginia) has large-acceptance spectrometers in Halls B and D and small acceptance spectrometers in Halls A and C.

**actinides:** Elements from 89 (actinium) to 103 (lawrencium). See also [transuranics](#).

**acute dose:** A large dose of [radiation](#) received in a short period of time.

**alpha decay:** The radioactive decay of an unstable heavy [nuclide](#) where the nuclide emits an [alpha particle](#), reducing the number of neutrons and the number of protons in the resulting nucleus by 2 each.

**alpha particle (or alpha rays):** The nucleus of a helium atom, containing 2 protons and 2 neutrons. Emitted by the [radioactive](#) decay of unstable heavy nuclides.

**atomic bomb:** Colloquial term for a [nuclear bomb](#) or [nuclear weapon](#).

---

## B

**background radiation:** The radiation people receive from terrestrial, cosmic, and medical sources.

**becquerel (Bq):** Metric system unit of radioactivity, corresponding to 1 nuclear decay per second. A nonmetric unit is the [curie](#).

**beta decay:** Radioactive decay of a nucleus that keeps the same atomic weight but increases or decreases the number of protons by 1. Beta-minus ( $\beta^-$ ) decay refers to the radioactive decay of a neutron-rich isotope, where 1 neutron decays into a proton, an electron, and an antineutrino; beta-plus ( $\beta^+$ ) decay refers to the radioactive decay of a proton-rich isotope, where 1 proton decays into a neutron, a positron (the antiparticle of the electron), and a neutrino.

**beta particle (or beta rays):** A high-energy [electron](#) (“beta-minus”) or [positron](#) (“beta-plus”) of keV to MeV, when emitted by the [beta decay](#) of an unstable [nuclide](#).

**big bang:** The expansion of the universe from its original high-temperature, high-density state.

**binding energy:** Average energy per nucleon needed to completely remove all the nucleons from a nucleus. Alternatively, it is the energy gained by assembling the nucleons into the nucleus.

**bomb peak:** An excess of carbon-14 in the atmosphere due to above-ground nuclear bomb tests during the 1950s and 1960s. Used to precisely [carbon-date](#) modern samples.

**brachytherapy:** A type of [radiation therapy](#) for cancer treatment through either permanently implanted [seeds](#) or temporary introduction of radioactive material via implanted tubes (catheters).

**bremstrahlung:** Meaning “braking radiation,” this radiation consists of x-ray and gamma-ray photons emitted by high-energy electrons as they pass through matter. Matter containing nuclei with large numbers of protons, such as lead or tungsten, causes electrons to emit more bremsstrahlung radiation than matter with lighter nuclei. This effect is used by x-ray machines to produce x-rays.

**burnup rate:** The fraction of the fuel of a nuclear reactor that is fissioned—typically about 5% today.

---

## C

**calorimeter, electromagnetic:** A detector that measures the energy of a particle, typically alternating layers of lead (or iron) and scintillator. Electromagnetic calorimeters use **bremsstrahlung** radiation and pair production in the lead to make an electromagnetic shower and measure the total energy of the showering particles in the scintillators.

**carbon dating:** Method using the amount of **radioactive** carbon-14 (half-life = 5700 years) in an organic sample to determine when the plant or animal it came from died.

**centrifuge:** A rapidly spinning device used to **enrich** uranium.

**chain reaction:** A reaction where the neutrons released from the fission of one nucleus of uranium or plutonium go on to fission other nuclei. If the neutrons from one fission go on to fission exactly one more fission, then the chain reaction is **critical** and continues at the same rate.

**charge density:** Amount of electric charge per unit volume (or per unit area, or per unit length).

**chart of nuclides:** Any chart or table arranging all the known **nuclides** by number of protons versus number of neutrons, together with their decay mode, half-life, and other properties. The nuclear equivalent of the periodic table. See [PAGE 274](#).

**Cherenkov (Cerenkov) counter:** A type of particle detector that measures particle speed by detecting Cherenkov radiation (the flash of light) given off by a particle as it traverses the material in the detector. There are several variants, including a threshold Cherenkov counter, which

just detects the flash of light, and a ring-imaging Cherenkov (RICH) counter, which measures the opening angle of the emitted cone of light. The threshold Cherenkov counter just determines if the particle's speed is faster than the speed of light in the material; the RICH measures the speed from the opening angle of the cone.

**Cherenkov radiation:** Light emitted when a charged particle that passes through a medium is traveling faster than the speed of light in that medium. This electromagnetic boom is analogous to the sonic boom produced when an object, such as an airplane or the tip of a whip, travels faster than the speed of sound in air. The speed of light in vacuum is always  $2.9979 \times 10^8$  meters per second, but the speed of light in material depends on the material. Light is up to about 0.1% slower in gasses and about 25% slower in water.

**Chernobyl (Ukraine):** Site of the worst nuclear power plant accident. The graphite-moderated, water-cooled reactor suffered an uncontrolled nuclear reaction and fire that resulted in the dispersal of radioactive material across very wide areas.

**China syndrome:** Hypothetical accident scenario where the nuclear fuel in a reactor core not only experiences a core meltdown, but also continues melting downward through the pressure vessel, thereby escaping to release huge amounts of radiation. It has not happened yet.

**chronic dose:** A dose of radiation received over an extended period of time.

**CNO cycle:** A process for fusing 4 protons into helium in stars, where a nucleus of carbon, nitrogen, or oxygen (CNO) serves as a catalyst. Less important than the PP chain in the Sun, but more important in heavier stars.

**collimator:** Combllike device in front of a gamma camera that defines the direction of the measured gamma rays.

**computed tomography (CT):** Three-dimensional x-ray image reconstructed from many different beams of x-rays, requiring 100 to 1000 times as much radiation exposure (roughly 1 to 20 millisieverts) as conventional x-rays.

**control rods:** Rods made of a material, such as cadmium or boron, with a very large neutron absorption [cross section](#) that can be inserted into a [reactor](#) to absorb [neutrons](#) and reduce the reaction rate.

**core meltdown:** See [meltdown](#).

**cosmic radiation:** Radiation from outer space. Caused by high-energy protons and alpha particles hitting the atmosphere and making a shower of other particles. Most cosmic radiation is screened by the Earth's magnetic field and atmosphere. Almost all of the particles that reach the ground are [muons](#).

**cosmic ray:** One particle of [cosmic radiation](#); when reaching Earth, typically a [muon](#).

**critical:** A [chain reaction](#) is critical if it continues at the same rate without increasing or decreasing. See also [subcritical](#) and [supercritical](#).

**critical mass:** The amount of a [fissile](#) material required to sustain a [chain reaction](#).

**Crookes tube:** An early experimental electric discharge tube that was discovered to emit x-rays.

**cross section:** Used to describe the probability that a high-energy particle will interact with a target nucleus or target particle. The total cross section is the effective area of the target as “seen” by the incoming particle. For example, the total cross section for a high-energy proton to interact with a uranium nucleus is approximately the cross-sectional area of the nucleus. The total cross section for a high-energy electron to interact with the same uranium nucleus is much smaller because it interacts via

the electromagnetic force, which is much weaker than the strong nuclear force. There are also differential cross sections, which are the probabilities or effective areas for an incident particle to interact with the target in specific ways, whether scattering at a particular angle, with a particular energy, or through a particular reaction mechanism.

**CT scan:** See [computed tomography](#).

**curie (Ci):** Unit of radioactivity corresponding to  $3.7 \times 10^{10}$  nuclear decays per second.  $1 \text{ Ci} = 3.7 \times 10^{10} \text{ Bq}$ .

**curve of binding energy:** The [binding energy](#) of nuclei plotted versus nuclear mass. It increases rapidly for light nuclei from hydrogen to helium (7 MeV per nucleon), continues to increase up to iron or nickel (8 MeV per nucleon), and then decreases slowly to the very heavy elements (about 7 MeV per nucleon).

**cyclotron:** A type of accelerator invented by Ernest O. Lawrence in 1934 that uses a large magnet to make the accelerated particles travel in increasing circles and an alternating voltage to accelerate the particles as they pass through the gap between the magnet Ds. Compare with [synchrotron](#).

---

## D

**dating, luminescence:** Dating crystalline materials using the light emitted (luminescence) when heated (thermoluminescence) or illuminated (optically stimulated luminescence). The total light emitted is proportional to the age of the sample.

**dating, radioisotope:** Dating materials using either remaining [abundances](#) of [radioisotopes](#), such as carbon-14 or krypton-81, or the ratios of [isotopes](#). See also [carbon dating](#).

**deep inelastic scattering:** An interaction where an incident [electron](#) or [muon](#) scatters from a [quark](#) in a [nucleon](#) or in the [nucleus](#).

**delayed neutrons:** Neutrons emitted from the radioactive decay of [fission fragments](#) following nuclear fission. See also [prompt neutrons](#).

**depleted uranium:** Uranium with less than the natural abundance of uranium-235.

**detector:** A device that amplifies and detects the tiny amounts of energy left behind by a particle as it traverses the material of the detector to determine the arrival time, speed, energy, or position of the particle. Types of detectors include [calorimeters](#), [Cherenkov counters](#), [drift chambers](#), [photomultiplier tubes](#), [scintillators](#), [spectrometers](#), and [wire chambers](#).

**deuterium:** Heavy hydrogen, with 1 proton and 1 neutron orbited by 1 electron.

**deuteron:** The nucleus of heavy hydrogen, with 1 proton and 1 neutron.

**dipole magnet:** A magnet that makes a constant magnetic field perpendicular to the direction of the charged particles to bend the trajectory of the charged particles. The larger the magnetic field and the smaller the particle momentum, the more the trajectory bends. Used in accelerators to steer the beam and used in spectrometers to measure the momentum of each particle.

**dirty bomb:** Radioactive materials dispersed by conventional explosive. Aims to contaminate large areas by spreading the radioactive material widely.

**diverter:** Removes helium-4 “ash” from a [tokamak](#) reactor.

**drift chamber:** A type of [wire chamber](#) that measures the time it takes for the electrons knocked loose by the passage of the high-energy particle through the wire chamber to reach a wire and be detected. It uses the timing information to determine the location of the charged particle much more precisely.

**dynode:** Intermediate electrode in a [photomultiplier tube](#).

---

## E

**elastic scattering:** A type of reaction where neither the incident particle nor the target is changed and kinetic energy is conserved. This contrasts with [inelastic scattering](#), where either the incident particle or the target is changed, whether by changing to an excited state, by creating more particles, by melding the incident particle and the target, or by knocking particles out of the target. In inelastic scattering, kinetic energy is typically transformed to exciting or altering the target nucleus. See also [quasielastic scattering](#).

**electron:** Elementary particle with mass  $0.5 \text{ MeV}/c^2$  and spin  $\frac{1}{2}$ . Electrons orbit the nucleus to form atoms. Emitted at high energy in [beta decay](#) (specifically in  $\beta^-$  decay). The antiparticle of the [positron](#). Used in accelerator labs to study nuclei in high-energy collisions.

**electron volt (eV):** Unit defined by the energy gained by an electron passing through a potential difference of 1 volt. This unit is used to describe subatomic energies. Because of the principle of special relativity and its corollary,  $E = mc^2$ , this is used for energy (eV), momentum (eV/c), and mass (eV/c<sup>2</sup>). In nuclear physics, it is much more common to use keV (kilo, or thousand), MeV (mega, or million), GeV (giga, or billion), and TeV (tera, or trillion).

**element:** Any nucleus with a specific number of protons (e.g., any nucleus with 6 protons is the element carbon).

**EMC effect:** A measurement by the European Muon Collaboration that compared the [quark](#) distributions inside nucleons in heavy nuclei with those inside deuterium. It found that quarks in nucleons in heavy nuclei move more slowly than quarks in free nucleons or in deuterium.

**enriched uranium:** Uranium with more than the natural [abundance](#) of uranium-235. Low-enriched uranium has less than 20% uranium-235; high-enriched uranium has more than 20% uranium-235.

**excitation energy:** Energy difference between an excited state of a nucleus or nucleon and the [ground state](#) of that nucleus or nucleon. For example, the first excited state of carbon-12 has additional energy of 4.4 MeV.

**excited state:** State of a system (atom, nucleus, or nucleon) that has more energy than the [ground state](#). The difference in energy between the ground state and an excited state is the [excitation energy](#). See also [metastable isotope](#).

---

## F

**fertile isotope:** An isotope that becomes [fissile](#) when it absorbs a neutron. Examples include thorium-232 and uranium-238.

**fissile isotope:** An isotope that will [fission](#) when it absorbs a neutron. Fissile isotopes include uranium-233 and uranium-235 as well as plutonium-239.

**fission:** The process of splitting a nucleus into 2 smaller nuclei, plus 2 to 3 neutrons. Energy can be released by fissioning nuclei much heavier than iron. See also [reactor](#).

**fission, accelerator-driven:** A subcritical fission reactor where the extra neutrons needed to maintain the chain reaction are supplied by a particle accelerator.

**fission fragments:** Smaller nuclei resulting from [nuclear fission](#).

**Fukushima:** Site in Japan of a nuclear power plant containing 6 [reactors](#) where a tsunami resulted in a [loss-of-coolant accident](#) and the [meltdown](#) of 4 of the reactors.

**fusion:** Process of fusing 2 nuclei into 1 larger nucleus. Typically requires high temperatures and confinement of light nuclei under high pressures at high densities. Energy can be released by fusing light nuclei into nuclei lighter than iron (26 protons). Gravitational confinement is used in stars; inertial confinement involves hitting a fuel pellet hard from all directions, usually with powerful laser beams, to compress the fuel; and magnetic confinement, used in [tokamaks](#), relies on magnetic fields to confine the fuel.

---

## G

**gamma camera:** Detector used to make an image with gamma rays. It comprises a [collimator](#), a [scintillator](#), and [PMTs](#). Used for [PET](#) and [SPECT](#) scans.

**gamma rays:** High-energy photons (with more than 100 keV). Can be emitted by the decay of nuclei from an excited state to a lower-energy state (typically from 100 keV to a few MeV). Can also be produced in accelerators at higher energies.

**gaseous diffusion:** Technique used to [enrich](#) uranium.

**Geiger counter:** Detector consisting of a metal tube containing a gas with a fine wire running down the center of the tube. When a particle or photon interacts in the gas, it knocks atomic electrons loose. As the atomic electrons drift to the wire, they are amplified by the potential difference (voltage) between the tube walls and the wire. This amplifies them into a

large enough spark that they can make an audible click. Modern Geiger counters don't emit the audible click but do emit an electronic chirp when they detect the signal from a particle.

**Geissler tube:** Early vacuum tube, first attempted in 1857, that led to more sophisticated vacuum tubes, including x-ray tubes.

**generator, radioisotope:** Device used to make [radioisotopes](#) for medical imaging. It contains a longer-lived isotope that decays to the shorter-lived desirable isotope. For example, a technetium-99 generator contains molybdenum-99, which has a 66-hour [half-life](#) and decays to technetium-99\*, which has a 6-hour half-life.

**gluon:** The particle that carries the [strong nuclear force](#) between [quarks](#). [Protons](#) and [neutrons](#) are each comprised of [quarks](#) and [gluons](#).

**graphite:** Soft form of carbon that is extremely resistant to heat. See [reactor, graphite](#).

**gray (Gy):** The metric system unit of absorbed radiation dose corresponding to an absorbed energy of 1 J/kg. See also [rad](#).

**ground state:** Lowest energy state of a nuclide or of an atom. Contrasts with [excited state](#) and [metastable isotope](#).

---

## H

**half-life:** Time it takes for half the nuclei of a radioisotope to decay.

**heavy water:** Water (H<sub>2</sub>O) where the hydrogen atoms are replaced with [deuterium](#) (an isotope of hydrogen with 1 proton and 1 neutron).

**helium burning:** Process where stars fuse helium into carbon or oxygen. This occurs after exhausting the hydrogen in their cores.

---

## I

**inelastic scattering:** See [elastic scattering](#).

**ion beam analysis:** Irradiating a sample with low-energy ions from an accelerator and detecting the characteristic x-rays emitted by materials on the surface of the sample. The frequency of the x-rays tells us the isotopes on the surface of the sample.

**isotone:** Nuclei with the same number of neutrons and differing numbers of protons (e.g., carbon-12 and nitrogen-13 are isotones of neutron number 6).

**isotope (a.k.a. nuclide):** Variants of an element with different numbers of neutrons (e.g., carbon-12 is an isotope of carbon with 6 neutrons, and carbon-14 is an isotope of carbon with 8 neutrons). See also [metastable isotope](#).

---

## J

**jet:** Spray of particles produced when a very-high-energy [quark](#) is knocked out of a [nucleon](#).

---

## L

**light water:** Regular water ( $H_2O$ ) composed of the most common isotopes of hydrogen and oxygen: hydrogen-1 and oxygen-16.

**linear accelerator (linac):** A particle accelerator, typically used to accelerate electrons, where the elements are all in a straight line. The Stanford Linear Accelerator Center (SLAC) was the highest-energy electron accelerator in the world for many years. Jefferson Lab has 2 linear accelerators, connected by recirculating arcs, so that the electrons can be accelerated up to 5 times.

**liquid-drop model:** Accurately characterizes the masses of most **nuclide** by describing the nucleus as a charged liquid drop. See **shell model**.

**loss-of-coolant accident (LOCA):** An accident at a **reactor** where the fission **chain reaction** stops, but the heat generated by the **residual radioactivity** in the core causes the temperature to rise dramatically. The Three Mile Island and Fukushima accidents were both caused by loss of coolant.

---

## M

**magnet:** Creates the magnetic field used to bend the trajectories of charged particles. There are several common magnet configurations: **dipole magnets**, **quadrupole magnets**, **solenoid magnets**, and **toroidal magnets**.

**magnetic resonance imaging (MRI):** A method of imaging that relies on aligning the spins of certain nuclei to measure their density. Typically uses huge magnets to align the spins of some of the hydrogen nuclei in the human body to measure their density. Previously called nuclear magnetic resonance imaging (NMRI).

**mass spectrometer:** Uses electric and magnetic fields to measure the masses of atoms.

**meltdown:** What can happen when the fuel rods in the core of a **nuclear reactor** suffer a **loss-of-coolant accident**. The fuel rods can heat up and melt down into a puddle of metal at the bottom of the **reactor vessel**.

**metastable isotope:** An excited state of an isotope that has a somewhat “long” **half-life**, indicated with an asterisk (\*) or “m.” For example, technetium-99\* or technetium-99m refers to a metastable state of technetium-99 that has a half-life of about 6 hours.

**mixed oxide (MOX) fuel:** Reactor fuel that is about 95% uranium-238 and 5% plutonium.

**moderate:** To slow neutrons down in a nuclear reactor, by having them collide elastically with a light-nuclei moderator, such as hydrogen, deuterium, or carbon. Moderating (i.e., slowing) the speed of neutrons increases the probability that they will fission a uranium-235 nucleus and continue the chain reaction. See [thermalize](#).

**muon:** A heavy cousin of the electron, with 200 times the mass. The most common component of cosmic radiation at the Earth's surface.

---

## N

**neutrino:** A neutral, ultralight particle that only interacts via the weak interaction. Emitted in beta decay. Neutrinos have been detected from the [PP chain fusion](#) in the Sun as well as from supernovas.

**neutron:** One of 2 particles that comprise the nucleus of the atom. Has zero charge, mass  $939.6 \text{ MeV}/c^2$ , and spin  $\frac{1}{2}$ . Made of 1 up quark and 2 down quarks.

**neutron activation analysis:** A technique of bombarding a sample with [neutrons](#). The composition of the entire sample can be determined by measuring the radiation given off by activated nuclei in the sample—i.e., nuclei that were excited by or absorbed a neutron and are now radioactive.

**neutron star:** A star composed almost entirely of [neutrons](#) that can pack the entire mass of the Sun into a sphere of radius about 10 kilometers. The densest object known (other than black holes).

**nuclear fission:** See [fission](#).

**nuclear fusion:** See [fusion](#).

**nuclear mass:** The total number of neutrons and protons in a nucleus; often abbreviated “ $A$ ”.

**nuclear physics:** The study of the nucleus of the atom and related phenomena.

**nuclear reactor:** See [reactor](#).

**nuclear resonance fluorescence:** Light given off by samples after being irradiated with gamma rays. The material of the sample can be determined from the frequency of the emitted light.

**nuclear weapon (or nuclear bomb):** A bomb where the energy comes from the fission of uranium or plutonium. See also [thermonuclear weapon](#).

**nucleon:** Any individual [proton](#) or [neutron](#).

**nucleosynthesis:** Process of making nuclei.

**nucleus (plural nuclei):** The entire group of protons and neutrons at the center of an atom.

**nuclide:** Nuclear physics term for an [isotope](#) (for example, carbon-14 and carbon-12 are nuclides).

---

## P

**pair production:** The process where a gamma ray with more than 1 MeV converts to a positron and an electron as it passes through matter.

**particle, elementary:** Particle with zero size and no structure. Examples thought to include [electrons](#), [positrons](#), [photons](#), [quarks](#), and [gluons](#).

**Pauli exclusion principle:** The principle that no 2 identical particles can have exactly the same spin, momentum, and position at the same time.

**PET:** See [positron-emission tomography](#).

**photomultiplier tube (PMT):** A vacuum tube used to convert tiny flashes of light into detectable electronic signals. The photons from the flash of light hit a photocathode and electrons are knocked out. The electrons are then accelerated by a potential difference (voltage) to the first **dynode**, where they knock out more electrons. The amplification process continues through between 4 and 12 dynodes until the amplified electronic signal can be read out from the anode. PMTs are very sensitive to light and can multiply a small current many times over, such that some PMTs can detect a single photoelectron knocked out from the photocathode. Photomultipliers can be used to count flashes of light from a [scintillator](#). Sometimes replaced by solid-state silicon PMTs.

**photon:** The fundamental quantum of light and carrier of the electromagnetic force. Light travels as a wave and interacts as a particle. The highest-energy photons are [gamma rays](#), followed by [x-rays](#).

**pion:** Lightest particle composed of a quark and an antiquark; interacts via the strong force. Produced in accelerator collisions and when cosmic rays hit Earth's atmosphere, decaying in nanoseconds via the [weak nuclear force](#) to a [muon](#) and a [muon-neutrino](#). In some models, pions “carry” the strong nuclear force between neutrons and protons.

**Planck's constant:** The constant that sets the scale for quantum mechanical behavior:  $h \approx 6 \times 10^{-34} \text{ J}\cdot\text{s} = 197 \text{ MeV}\cdot\text{fm}$ . For example, the quantum uncertainty in a particle's position times the uncertainty in its momentum is related to Planck's constant:  $\Delta x \Delta p \geq h/2\pi$ .

**polarized electrons:** Electron beams with a preferential spin orientation, where one spin state is preferred over another. Analogous to polarized light.

**positron:** Antiparticle of the electron, with the same mass and spin but opposite charge. When a positron hits an electron, the 2 particles can annihilate and convert all their mass into energy in the form of 2 photons. Also called a beta-plus ( $\beta^+$ ) particle because it is emitted in  $\beta^+$  decay.

**positron-emission tomography (PET):** Medical or other imaging using a radioactive nuclide that emits positrons. When a positron hits an electron in the material, the 2 particles annihilate and emit 2 photons (gamma rays) in opposite directions. Contrast with **SPECT**.

**PP chain:** The primary source of energy production in the Sun, which starts with 2 protons fusing to form a deuterium nucleus. The final result is that 4 protons fuse to form a helium nucleus, releasing a lot of energy.

**Project Orion:** A US study during 1958 to 1963 considering whether to propel spacecraft by dropping **nuclear bombs** out the back and using the blast to propel them forward.

**prompt neutrons:** Neutrons emitted immediately when uranium or plutonium **fissions**. See also **delayed neutrons**.

**proton:** One of 2 particles that comprise the nucleus of the atom. Has positive charge, mass  $938.3 \text{ MeV}/c^2$ , and spin  $\frac{1}{2}$ . Made of 2 up quarks and 1 down quark. The number of protons is often abbreviated as “Z.”

**proton therapy:** Cancer treatment using proton beams instead of x-ray photon beams. Originally thought to be favorable mostly for solid tumors that are localized and isolated, but the addition of pencil-beam aim and intensity modulation have also made larger and multisite tumors more treatable.

---

## Q

**quadrupole magnet:** Focuses a beam of charged particles similarly to how a lens focuses light. Used in accelerators and spectrometers.

**quantum chromodynamics (QCD):** Theory for understanding the strong force between quarks that is carried by gluons. See [strong nuclear force](#).

**quantum tunneling:** Process where a particle can emerge on the other side of a barrier without actually passing through the barrier. Important in [alpha decay](#) and in the first step of the [PP chain](#) for solar fusion.

**quark:** Constituent of the proton and neutron. Up quarks have mass  $\approx 5 \text{ MeV}/c^2$ , spin  $\frac{1}{2}$ , and charge  $+\frac{2}{3}$ . Down quarks have mass  $\approx 7 \text{ MeV}/c^2$ , spin  $\frac{1}{2}$ , and charge  $-\frac{1}{3}$ . A nucleon is composed of 3 valence quarks and an indefinite number of virtual quark-antiquark pairs (sea quarks) and gluons.

**quasielastic scattering:** Elastic scattering from a moving nucleon inside a nucleus where the nucleon is ejected from the nucleus but the rest of the nucleus is left relatively unperturbed. This is different from [elastic scattering](#) from the nucleus as a whole, where the entire nucleus is left unchanged.

**Q value:** Ratio of energy released by a fusion reaction to the input energy needed to heat the plasma.

---

## R

**rad:** A unit of absorbed radiation dose, corresponding to an absorbed energy of  $0.01 \text{ J/kg}$ .  $100 \text{ rad} = 1 \text{ Gy}$ . See also [gray](#).

**radiation:** The high-energy (keV to MeV) particles emitted by radioactive materials. The most common forms of radioactivity are [alpha](#), [beta](#), and [gamma](#) rays.

**radiation detector:** See [detectors](#).

**radiation portal monitor:** Detectors placed at ports and airports to look for radioactive material.

**radiation therapy:** Applying radiation to tumors to treat cancer. Treatment can either use external beams (e.g., x-rays, gamma rays, or protons) or internal radiation sources (e.g., [brachytherapy](#)).

**radioactive tracer:** A [radioactive isotope](#) introduced into a person, an animal, or a plant. By measuring the emitted [radioactivity](#), we can trace how the isotope was absorbed and traveled through the organism. Used in the [PET](#) scan and the [SPECT](#) scan.

**radioactivity:** The activity of [radioisotopes](#) or of radioactive material. Measured in [becquerels](#) (disintegrations per second) or [curies](#) ( $3.7 \times 10^{10}$  disintegrations per second). Each disintegration results in the emission of at least 1 high-energy particle.

**radio-frequency cavity:** See [accelerating cavity](#).

**radioisotope:** Short for radioactive isotope (e.g., fluorine-18, which is used in [PET](#) scans). Any isotope that emits radiation.

**reactor:** A device for sustaining a nuclear [fission chain reaction](#), typically using [fissile isotopes](#) of uranium and plutonium. Nuclear reactors can also convert [fertile isotopes](#) into [fissile isotopes](#). Can be either [thermal reactors](#) (moderated with [light water](#), [heavy water](#), or [graphite](#)) or unmoderated [fast reactors](#) (including [molten-salt](#) and [thorium](#) reactors). Thermal, or fast, [breeder reactors](#) produce more fissile material than they consume. For a reactor design that relies on nuclear [fusion](#), see [tokamak](#).

**reactor, breeder:** A fission reactor that produces more [fissile](#) fuel than it consumes, by converting [fertile](#) isotopes into [fissile](#) ones.

**reactor, fast:** A fission reactor that uses unmoderated, or fast, neutrons to fission nuclei.

**reactor, graphite:** A fission reactor design that uses a graphite (carbon) moderator. The Chernobyl-style reactors common in the Soviet Union were graphite-moderated. An advanced (fourth-generation) graphite reactor is a high-temperature gas-cooled reactor, which uses helium coolant. For an example, see [reactor, pebble-bed](#).

**reactor, heavy-water:** A [thermal reactor](#) that uses [heavy water](#) to [moderate](#) the [neutrons](#). Does not need enriched uranium to operate.

**reactor, light-water:** A [thermal reactor](#) that uses regular water to [moderate](#) the [neutrons](#). The most common type of power reactor in the world, used extensively on nuclear-powered naval vessels and in commercial power plants. Includes both pressurized-water reactors (PWR) and boiling-water reactors (BWR).

**reactor, molten-salt:** A fission reactor design where the fissile material is dissolved in a molten salt, which flows through channels in graphite and is brought together in the core, where it can fission. See also [reactor, thorium](#).

**reactor, pebble-bed:** A possible [graphite](#)-moderated, high-temperature gas-cooled reactor that would have its fuel encased in layers of protective carbon.

**reactor, thermal:** Any reactor that uses a moderator to [thermalize](#) the neutrons emitted by fission reactions, to increase their absorption [cross sections](#) and the probability that they will [fission](#) a subsequent nucleus.

**reactor, thorium:** A type of [molten-salt reactor](#) where molten thorium fluoride flows through the reactor core. Thorium is [fertile](#), so when it absorbs a neutron, it ends up as uranium-233, which is [fissile](#). The uranium-233 sustains the [chain reaction](#), releasing energy and more neutrons that create more uranium-233.

**reactor vessel:** The thick steel pressure vessel that typically encloses [light-water reactors](#).

**rem:** A unit of radiation dose equivalent. It is the dose in **rads** adjusted for the relative biological effect of different particles. 100 rem = 1 Sv. See also **Sievert**.

**reprocessing:** The processing of **spent nuclear fuel** to remove leftover uranium and plutonium (about 95% of the spent fuel). The reprocessed uranium and plutonium can be converted into **mixed oxide fuel**.

**residual radioactivity:** About  $\frac{1}{5}$  of the power liberated by **nuclear fission** comes from the delayed radioactive decay of the **fission fragments**. The power released decreases from about 20% immediately after the **chain reaction** stops to about 2% a day later.

---

## S

**scintillant:** Any material that luminesces when excited by radiation. These can be inorganic crystals, such as sodium iodide, or organic plastics or liquids.

**scintillator:** Detector of both charged and uncharged high-energy particles that combines a **scintillant**, which emits light when excited by radiation, and a **photomultiplier tube**, which converts the flash of light into a measureable electronic signal. Inorganic scintillator detectors typically have excellent energy resolution. Organic (plastic) scintillator detectors typically have excellent time resolution (1 nanosecond or less).

**seed:** A small encapsulated **radioactive** source implanted in or around a tumor used for cancer treatment. See **radiation therapy** and **brachytherapy**.

**shell model:** A model of the nucleus where the constituent protons and neutrons orbit in *s*-shell, *p*-shell, *d*-shell, etc., orbitals. Adapted from a similar model of the atom, where the orbiting particles are electrons.

**Sievert (Sv):** The metric system unit of radiation dose equivalent. It is the dose in [grays](#) adjusted for the relative biological effect of different particles. See also [rem](#).

**single-photon emission computed tomography (SPECT):**

Gamma-camera technique that images the source of single gamma rays emitted directly from a radionuclide in a person's body. Contrast with indirect emission of gamma rays in [PET](#).

**solenoid magnet:** A cylindrical magnet where the magnetic field is parallel to the cylinder. Used in some spectrometers so that the incident particle beam is parallel to the magnetic field and is therefore not deflected. Particles emerging from collisions between the incident beam and the target travel at an angle to the field and hence are deflected. This makes low-energy particles travel in small, tight circles so that they are not detected and allows measurement of the momentum of higher-energy particles.

**SPECT:** See [single-photon emission computed tomography](#).

**spectrometer:** A magnet plus detectors. Usually built around a magnet.

The detectors measure the trajectory of the charged particles. Physicists can reconstruct the particle momenta by measuring how much their trajectories bend in the magnetic field of the magnet. Physicists combine position-sensitive detectors, such as wire chambers, with time-, energy-, and velocity-sensitive detectors to determine the particle's momentum and identity ([proton](#), [electron](#), [pion](#), [deuteron](#), etc.).

**spent nuclear fuel:** The fuel after being removed from a nuclear reactor.

Typically contains less uranium-235, more plutonium and other [transuranics](#), and a lot of highly radioactive fission products.

**spin:** The intrinsic angular momentum of a particle. The electron has spin  $\frac{1}{2}$ , so it can be either spin up or spin down. When particles are polarized, they are spin-aligned.

**strong nuclear force:** The force, explained by [quantum chromodynamics](#), that holds quarks together to form nucleons and that holds nucleons together to form nuclei.

**subcritical:** A [chain reaction](#) where the [neutrons](#) released from the [fission](#) of 1 nucleus of uranium or plutonium go on to fission less than 1 other nucleus so that the fission rate decreases steadily.

**superconductivity:** When some materials are cooled to very low temperatures, their resistance to electrical currents drops to zero. This means that no energy is wasted and converted to heat by the electrical resistance. This allows the use of much higher electrical currents to achieve much greater electric and magnetic fields. This is often used in spectrometer [magnets](#) and in [accelerating cavities](#). Superconducting radio-frequency accelerating cavities are referred to as SRF cavities.

**supercritical:** A [chain reaction](#) where the [neutrons](#) released from the [fission](#) of 1 nucleus of uranium or plutonium go on to fission more than 1 other nucleus so that the fission rate increases exponentially.

**supernova:** Explosion of a massive star. This occurs after it has finished fusing lighter nuclei to heavier nuclei and now has an inert iron core. The star collapses and then rebounds to blow off its outer layers and briefly shine brighter than its entire galaxy. This is the source of many of the heavy elements in the universe.

**synchrotron:** Circular accelerator in which the radius of the particles is kept constant by synchronizing the increasing strength of the magnetic field with the increasing energy of the accelerated particles. This is used at the Fermi National Accelerator Lab and Brookhaven's Relativistic Heavy Ion Collider in the United States and at the Large Hadron Collider at the European Organization for Nuclear Research (CERN) in Europe.

**synchrotron radiation:** As particles approach relativistic speeds, they leak increasing amounts of electromagnetic radiation (usually x-rays), which has practical applications in spectroscopy and crystallography but also places an upper limit on the energy attainable by a synchrotron accelerator.

---

## T

**technetium-99:** Isotope whose metastable form is the most commonly used for SPECT scans.

**temperature:** The average kinetic energy of the particles in the substance. A temperature of 1 Kelvin corresponds to an average kinetic energy per particle of  $10^{-4}$  electron volts.

**Tesla coil:** A transformer that produces very-high-voltage, high-frequency electrical discharges.

**thermalize:** To reach a temperature equilibrium by losing or gaining energy in the form of heat. A thermal neutron has had many collisions with nuclei to end up with the same average kinetic energy as the nuclei it collides with. This average kinetic energy is described by the temperature. The thermal energy at room temperature (70° Fahrenheit, 20° Celsius, or 300 Kelvin) is about  $\frac{1}{4}$  of an electron volt. Neutrons in a nuclear reactor are sometimes *moderated* to thermalize them.

**thermonuclear weapon (or thermonuclear bomb):** A bomb where the energy released comes from both nuclear fission of uranium or plutonium as well as nuclear fusion of deuterium and tritium into helium. Releases much more energy than an ordinary *nuclear bomb*.

**thorium:** See *reactor, thorium*.

**Three Mile Island:** The site of a nuclear accident that resulted in a [core meltdown](#) of 1 of the 2 nuclear reactors.

**tokamak:** One approach for pursuing controlled nuclear fusion. It confines the ultrahigh-temperature plasma using magnets in the shape of a torus; the word “tokamak” comes from a Russian acronym for “toroidal magnetic chamber.” Examples include the Joint European Torus (JET) and Japan Torus-60.

**toroidal magnet:** Magnet where the direction of the magnetic field follows the donut shape of a torus. Used in the large-acceptance spectrometer (CLAS) in Hall B at Jefferson Lab. Also used in [tokamak](#).

**transuranics:** Isotopes with more than 92 protons (uranium). See also [actinides](#).

**tritium:** A heavy radioactive [isotope](#) of hydrogen that has 1 [proton](#) and 2 [neutrons](#). Used in [thermonuclear weapons](#) and in controlled [nuclear fusion](#).

---

## V

**valley of stability:** The most stable nuclide of each [nuclear mass](#) on the [chart of nuclides](#). Nuclides with more protons or more neutrons will either be less bound or less stable (or both) than the nuclide at the bottom of the valley.

**Van de Graaff generator:** An early particle accelerator invented at Princeton in the 1930s. It uses a constant high voltage created by the mechanical transport of electrons to one terminal of the generator to accelerate charged particles. Some are still used as low-energy (several MeV) accelerators today.

**virtual particles:** Particles that only exist momentarily, usually in the form of particle-antiparticle pairs. They pop out of the vacuum for a brief moment and then annihilate.

---

## W

**weak nuclear force:** The force that causes beta decay. Much weaker than the strong nuclear force.

**wire chamber:** A type of particle detector that measures the position of a high-energy charged particle passing through it. It is filled with gas and contains hundreds or thousands of very fine wires at high voltage. A high-energy charged particle passing through the gas will knock out many atomic electrons. In the electric field formed by the wires, the electrons will drift to the nearest sense wire. Close to the sense wire, the electric field will cause an electron avalanche, amplifying the electric signal so that it can be detected. The position of the charged particle is given by the location of the sense wires that carried the electric signals. See also [drift chamber](#).

---

## X

**x-rays:** High-energy photons (typically from 1 to 100 keV). Can result from nuclear decay. Used commonly in medical imaging for standard 2-dimensional x-ray imaging and for 3-dimensional CT scans.

**x-ray fluorescence:** Lower-frequency x-rays given off by samples after being irradiated with x-rays. The material of the sample can be determined from the frequencies of the emitted x-rays.

# SELECT NUCLEAR PHYSICS RESEARCH FACILITIES

**BNL:** Brookhaven National Laboratory, Long Island, New York

**CERN:** French acronym of European Organization for Nuclear Research, including the LHC, near Geneva, Switzerland

**DESY:** Deutsches Elektronen-Synchrotron, Hamburg, Germany

**Fermilab:** Fermi National Accelerator Laboratory, near Chicago, Illinois

**FAIR:** Facility for Antiproton and Ion Research, Darmstadt, Germany

**FRIB** ["eff-rib"]: Facility for Rare Isotope Beams, East Lansing, Michigan

**ITER:** International Thermonuclear Experimental Reactor, Provence, southern France

**JLab:** Thomas Jefferson National Accelerator Facility, Newport News, Virginia

**J-PARC:** Japan Proton Accelerator Research Complex, Ibaraki, eastern Japan

**LHC:** Large Hadron Collider, at CERN, near Geneva, Switzerland

**MAMI:** Mainz Microtron, Mainz, Germany

**PSI:** Paul Scherrer Institute, Villigen, northern Switzerland

**RHIC** [“rick”]: Relativistic Heavy Ion Collider, at BNL, Long Island,  
New York

**SLAC**: Stanford Linear Accelerator Center, California; later named SLAC  
National Accelerator Laboratory, Menlo Park, California

# TIMELINE

- 1895 ..... Wilhelm Röntgen discovers x-rays, earning the first Nobel Prize in Physics in 1901.
- 1896 ..... Henri Becquerel accidentally discovers uranium emissions on photographic plates.
- 1896 ..... J. J. Thomson discovers the electron.
- 1898 ..... Becquerel's student Marie Curie coins the word "radioactive" and discovers thorium (element 90); Marie and Pierre Curie search for other radioactive elements, discovering polonium (element 84) and radium (element 88).
- 1899 ..... Frederick Soddy and Ernest Rutherford discover and name half-life of radioactive elements.
- 1903 ..... Marie Curie, PhD, completes thesis, "Research on Radioactive Substances," and shares Nobel Prize with Pierre Curie and Henri Becquerel.
- 1903 ..... Rutherford names alpha and beta radiation.
- 1903 ..... William Henry Bragg shows that protons or alpha particles deposit their peak energy (later named the Bragg peak) just before they stop.
- 1904 ..... Doctor/dentist William H. Rollins recommends shielding to protect patients and doctors from unnecessary x-ray exposure.

- 1908** ..... Rutherford demonstrates that alpha “rays” are particles of helium nuclei.
- 1908–1911** ..... Rutherford’s lab assistant Hans Geiger develops a device for counting alpha particles.
- 1910** ..... Rutherford demonstrates by reflection of alpha particles that atoms are mostly empty, with only a tiny “nucleus” that contains all of the positive charge.
- 1911** ..... Hungarian physicist Georg Charles von Hevesy uses trace amounts of radioactive lead to demonstrate that leftover meat at a hostel had been reprocessed into 2 different dinner meals.
- 1913** ..... First mention of “isotopes” in print (Soddy).
- 1914** ..... First mention of “atomic bombs” (in H. G. Wells’s novel *The World Set Free*).
- 1919** ..... First artificial nuclear reaction, as alpha beam turns nitrogen into oxygen (Rutherford).
- 1920** ..... Arthur Eddington proposes nuclear fusion model of the Sun, based on Francis Aston’s precise measurement of atomic masses.
- 1920** ..... Rutherford proposes existence of neutrons to explain why atomic weight differs from atomic number.
- 1923** ..... Radioactive tracer proposed (chemist von Hevesy).
- 1927** ..... Radioactive tracers used to diagnose heart disease (Dr. Hermann Blumgart).

- 1928 ..... Geiger improves his counter, in collaboration with student Walther Müller, to detect many kinds of ionizing radiation.
- 1929 ..... Ernest O. Lawrence invents the cyclotron to accelerate nuclear particles to high speeds, eventually creating hundreds of radioactive isotopes (1939 Nobel Prize in Physics).
- 1929 ..... Linear accelerator first developed to accelerate protons using high voltage (Sir John Cockcroft and Ernest T. S. Walton).
- 1931 ..... Harold Urey discovers heavy hydrogen (deuterium) after constructing a chart of known and missing isotopes.
- 1932 ..... Heavy water deliberately concentrated using electrolysis by Urey and Edward Washburn.
- 1932 ..... Existence of the neutron confirmed when Rutherford student James Chadwick aims alpha particles at beryllium; Walton uses protons to split lithium atom.
- 1933 ..... Rutherford declares, “Anyone who says that with the means at present at our disposal and with our present knowledge we can utilize atomic energy is talking moonshine.” (*New York Times*, September 12)
- 1933 ..... Discovery of large magnetic moment for the proton by Otto Stern (1943 Nobel Prize in Physics) suggests that proton must have an internal structure.

- 1934** ..... Enrico Fermi discovers neutron-induced radioactivity by bombarding stable nuclei with neutrons (Nobel Prize 1938).
- 1934** ..... Tritium created when deuterium hit with deuterium nuclei by Rutherford, Mark Oliphant, and Paul Harteck.
- 1934** ..... Pavel Cherenkov first observes particles emitting blue radiation when traveling faster than the speed of light in water (Nobel Prize 1958).
- 1934** ..... Irène and Frédéric Joliot-Curie hit nuclei with alpha particles to create new radioactive isotopes.
- 1935** ..... Yukawa theory (named after Hideki Yukawa) of the strong nuclear force describes it as the result of nucleons exchanging mesons between them.
- 1938** ..... First attempted neutron therapy for cancer, using the Lawrence cyclotron by brother John Lawrence, but long-term side effects proved worse than for x-rays.
- 1938** ..... Lise Meitner and Otto Hahn discover and name nuclear “fission” after Hahn and Fritz Strassman use neutrons to split uranium and identify barium in the fission products.
- 1939** ..... Liquid-drop model of the nucleus as “surface tension” plus electrical repulsion proposed to explain fission and describe the curve of binding energy (Niels Bohr and John Wheeler).

- 1939** . . . . . Hans Bethe calculates a proton-proton chain reaction that describes nuclear fusion in stars (Nobel Prize 1967).
- 1942** . . . . . Manhattan Project team led by Fermi achieves first self-sustaining nuclear chain reaction (December 2, University of Chicago), using uranium and ultrapure graphite.
- 1942–1943** . . . . . Norwegian saboteurs and American bombers undermine Nazi collection of heavy water, intended as a uranium moderator for an atomic bomb.
- 1945** . . . . . Atomic bombs dropped on Japan; data from 120,000 survivors exposed to gamma radiation became a common baseline for assessing risks of other radiation exposure.
- 1946** . . . . . First proposal for proton therapy by Lawrence student Robert R. Wilson, who went on to design cyclotron at Harvard for proton radiosurgery and radiation therapy.
- 1947–1975** . . . . . US Atomic Energy Commission assumes civilian control over nuclear energy.
- 1947** . . . . . “Nuclide” proposed by Truman P. Kohman as a more general term than isotope to indicate a nucleus with a specific number of protons and neutrons.
- 1949** . . . . . First Soviet nuclear weapon tested.

- 1949–1950** . . . . . J. Hans D. Jensen and Maria Goeppert Mayer independently develop shell model of the nucleus to explain the stability of “magic” numbers of nucleons (Nobel Prize in 1963).
- 1950** . . . . . First true radioisotope imaging system, combines a Geiger counter with crystal components from photomultiplier tube (Dr. Benedict Cassen’s “scintiscanner”).
- 1951** . . . . . Electricity first generated from nuclear energy and demonstrates that a breeder reactor could produce more energy than it consumed (EBR-1 at Arco, Idaho).
- 1952** . . . . . France tests its first nuclear weapon.
- 1952** . . . . . The United Kingdom tests its first nuclear weapon.
- 1952** . . . . . First explosive to incorporate nuclear fusion, Ivy Mike (November 1, Enewetak atoll, Marshall Islands), leading to the first synthesis of elements 99 and 100 (einsteinium and fermium).
- 1953** . . . . . “Atoms for Peace” speech at the United Nations by President Dwight D. Eisenhower kicks off multiyear US program to support peaceful uses of nuclear energy around the world.
- 1953–1954** . . . . . First nuclear-powered submarine, USS *Nautilus*.
- 1954** . . . . . First full-scale nuclear power plant in the USSR (Obrinsk).

- 1957 . . . . . First full-scale nuclear power plant in the United States (Shippingport, PA).
- 1957 . . . . . Passage of the Price-Anderson Act in United States limits liability of nuclear plant utilities, vendors, and suppliers in case of accident.
- 1957 . . . . . First instance of proton therapy (Sweden).
- 1959–1989 . . . . . World’s first nuclear-powered surface vessel, the icebreaker *Lenin* (20,000 deadweight tons).
- 1958 . . . . . Saveli Feinberg proposes idea for a “breed-and-burn” reactor.
- 1958–1961 . . . . . Gamma camera (scintigraphy) invented by Hal Oscar Anger.
- 1960 . . . . . First fully commercial pressurized-water reactor (Yankee Rowe, MA) and first commercial boiling-water reactor (Dresden, IL).
- 1961 . . . . . First US instance of proton therapy (Harvard).
- 1961 . . . . . Nobel Prize to Robert Hofstadter for the first measurement of the size of the proton.
- 1964 . . . . . The People’s Republic of China tests its first nuclear weapon.
- 1965 . . . . . First nuclear reactor in space (43 days, 500 watts of power).
- 1967 . . . . . Gamma “knife” use of gamma rays in surgery pioneered by Lars Leksell.

- 1968** ..... Wire chamber (“multiwire proportional chamber”) particle detector invented by Georges Charpak (1992 Nobel Prize), making possible the study of very rare nuclear reactions.
- 1968–1969** ..... Evidence for quarks first observed from deep inelastic scattering of electrons from the proton, Stanford Linear Accelerator (1990 Nobel Prize to Jerome Friedman, Henry Kendall, and Richard Taylor).
- 1970** ..... Treaty on the Non-Proliferation of Nuclear Weapons enacted to limit the spread of nuclear weapons.
- 1971** ..... Magnetic resonance imaging (MRI) shows radio signal for hydrogen is more pronounced from tumors than for healthy tissue, due to extra water in tumors (Raymond Damadian).
- 1972–1973** ..... Computed tomography/computerized axial tomography (CT/CAT) of magnetic resonance information by Godfrey Hounsfield and Allan Cormack becomes the basis for computer-assisted planning of radiation treatment.
- 1973** ..... Arab oil embargo leads to orders for 41 US nuclear power plants in a single year.
- 1974** ..... French government undertakes to replace all oil-generated electricity with nuclear power.
- 1974** ..... India becomes the sixth country to make a public test of a nuclear weapon (12 kilotons), increasing concerns about proliferation of nuclear weapons.

- 1975 . . . . . US Nuclear Regulatory Commission established to regulate nuclear power.
- 1977 . . . . . First medical MRI of a human being (Damadian) and first prototype for rapid MRI via echo-planar imaging (Peter Mansfield).
- 1977–1981 . . . . . United States entirely bans commercial reprocessing of spent nuclear fuel in an effort to hinder weapons proliferation.
- 1979 . . . . . Three Mile Island nuclear reactor partial meltdown (March 28).
- 1983 . . . . . Finland declares that utility companies are responsible for disposal of waste from their nuclear power plants.
- 1985 . . . . . Soviet leader Mikhail Gorbachev meeting with President Ronald Reagan proposes international collaboration on nuclear fusion, leading to beginnings of the ITER tokamak.
- 1986 . . . . . First successful passive shutdown demonstration for a nuclear reactor (the sodium-cooled ERB-II in Idaho) without control system or a backup.
- 1986 . . . . . Chernobyl nuclear reactor accident (April 26), the most deadly and expensive ever, sends a large plume of radiation from Ukraine through northern Europe.
- 1987 . . . . . Voters in Italy (65% turnout) place restrictions on nuclear power via first national referendum; all 4 Italian nuclear power plants close by 1990.

- 1987** ..... US Congress votes to declare Yucca Mountain, Nevada, the sole site to be studied for a future government-run repository for US nuclear waste, despite the lack of nuclear power plants in Nevada; by contrast, in Finland the same year, 5 sites are selected for further study that are close to power plants run by the 2 utilities responsible for their own nuclear waste disposal.
- 1989** ..... Claims about achieving nuclear fusion at room temperature (“cold fusion”) in an electrochemical cell by Stanley Pons and Martin Fleischmann spark an unsuccessful worldwide attempt to replicate their results.
- 1991** ..... First gantry-based proton therapy (Loma Linda, CA).
- 1993** ..... Functional MRI (fMRI) introduced.
- 1993–2013** ..... Megatons to Megawatts Program converts more than 20,000 Soviet-era ICBM warheads into low-enriched uranium, which is sold to US nuclear power plants.
- 1995** ..... Jefferson Lab/CEBAF (Continuous Electron Beam Accelerator Facility) begins experiments with a 4-billion-electron-volt beam.
- 1996** ..... Comprehensive Nuclear-Test-Ban Treaty creates system of seismic and radionuclide monitoring stations to distinguish nuclear explosions from earthquakes.

- 1997 . . . . . Joint European Torus (JET) tokamak fusion reactor achieves 16 megawatts of gross power.
- 1998 . . . . . Pakistan becomes the seventh country to successfully test a nuclear weapon.
- 2000 . . . . . The Relativistic Heavy Ion Collider (RHIC) begins operation at Brookhaven National Laboratory in New York.
- 2003 . . . . . Northeast blackout in the United States and Ontario caused 17 nuclear reactors to enter “safe mode” shutdown (August 14).
- 2004 . . . . . Construction begins on world’s first long-term repository for high-level radioactive waste (Olkiluoto, Finland).
- 2005 . . . . . Lithuania begins shutting down its Chernobyl-style reactors.
- 2005 . . . . . US Energy Policy Act creates incentives to support construction of new nuclear reactors; a few states later allow utility companies to charge customers for the construction of nuclear power plants.
- 2006 . . . . . North Korea conducts its first nuclear test, 4 years after exiting the Treaty on the Non-Proliferation of Nuclear Weapons, with subsequent tests in 2009, 2013, 2016, and 2017.

- 2011..... Fukushima core meltdown disaster due to earthquake and tsunami that cause failure of cooling systems for 4 nuclear reactors. All of Japan's 54 nuclear reactors shut down over the following year.
- 2011..... German government shuts down 8 reactors built before 1985 and promises to close all remaining reactors over the next decade.
- 2015..... The first of Japan's 43 operable nuclear reactors is turned back on (Sendai, Kagoshima).
- 2016..... World's largest stellarator-type fusion reactor (Wendelstein 7-X) begins operation to demonstrate possibility of nonpulsed, continuous fusion.
- 2017..... Jefferson Lab/CEBAF (Continuous Electron Beam Accelerator Facility) completes upgrade from 6 billion electron volts to 12 billion electron volts.
- 2017..... Westinghouse, the world's oldest and largest supplier of commercial reactor technology (owned by Toshiba since 2006) files for bankruptcy in March.
- 2017..... NuScale Power (Oregon) submits first US design application for a small modular reactor.

# NOBEL LAUREATES

## Honored for Their Work in Nuclear Physics

- 1901..... Wilhelm Röntgen for discovery of x-rays;  
the first Nobel Prize in Physics
- 1903..... (shared) Henri Becquerel for discovering  
spontaneous radioactivity, and Pierre and Marie  
Curie for their research into radiation (Physics)
- 1911..... Marie Curie for discovering radium  
and polonium (Chemistry)
- 1917..... Charles Barkla for his discovery of the characteristic  
radiation from different elements (Physics)
- 1921..... Frederick Soddy for his investigations into the  
origin and nature of isotopes (Chemistry)
- 1922..... Francis Aston for discovering using a mass  
spectrometer of isotopes in a large number  
of nonradioactive elements (Chemistry)
- 1924..... Karl Siegbahn for his discoveries in the  
field of x-ray spectroscopy (Physics)
- 1934..... Harold Urey for discovering heavy  
hydrogen (Chemistry)
- 1935..... James Chadwick for the discovery  
of the neutron (Physics)

- 1935** ..... Frédéric and Irène Joliot-Curie for their synthesis of new radioactive elements (Chemistry)
- 1936** ..... (shared) Carl Anderson for the discovery of the proton and Victor Hess for the discovery of cosmic radiation (Physics)
- 1938** ..... Enrico Fermi for his discovery of new radioactive elements produced by neutron irradiation and for his work on slow neutron nuclear reactions (Physics)
- 1939** ..... Ernest O. Lawrence for inventing the cyclotron (Physics)
- 1943** ..... Otto Stern for discovering the magnetic moment of the proton (Physics)
- 1943** ..... Georg Charles von Hevesy for using isotopes as tracers in the study of chemical processes (Chemistry)
- 1944** ..... Otto Hahn for discovering nuclear fission (Chemistry)
- 1944** ..... I. I. Rabi for his resonance method of recording the magnetic properties of atomic nuclei (Physics)
- 1948** ..... P. M. S. Blackett for his development of the cloud chamber (Physics)
- 1949** ..... Hideki Yukawa for his prediction of the existence of mesons based on his theoretical work on nuclear forces (Physics)

- 1950 ..... Cecil Powell for his development of the photographic method of studying nuclear reactions (Physics)
- 1951 ..... Sir John Cockcroft and Ernest T. S. Walton for their pioneer work on the transmutation of atomic nuclei by artificially accelerated atomic particles (Physics)
- 1951 ..... Edwin McMillan and Glenn Seaborg for discoveries of transuranic elements (Chemistry)
- 1952 ..... Felix Bloch and Edward Purcell “for their development of new methods for nuclear magnetic precision measurements and discoveries in connection therewith” (Physics)
- 1958 ..... Pavel Cherenkov, Il’ja Frank, and Igor Tamm for their discovery that particles traveling faster than the speed of light in water emit electromagnetic radiation (Physics)
- 1960 ..... Donald Glaser for his invention of the bubble chamber (Physics)
- 1960 ..... Willard Libby for his discovery and use of carbon dating (Chemistry)
- 1961 ..... (shared) Robert Hofstadter for using electron scattering to study the structure of the proton and Rudolf Mossbauer for his discovery of coherent resonant absorption of gamma rays (Physics)
- 1963 ..... (shared) J. Hans D. Jensen and Maria Goeppert Mayer for developing the shell model of the nucleus to explain the stability of “magic” numbers of nucleons

- 1967 . . . . . Hans Bethe “for his contributions to the theory of nuclear reactions, especially his discoveries concerning the energy production in stars” (Physics)
- 1975 . . . . . Aage Bohr, Ben Mottelson, and Leo Rainwater for their discoveries in the structure of the nucleus (Physics)
- 1979 . . . . . Allan Cormack and Godfrey Hounsfield for the development of computer assisted tomography (CT scans) (Medicine or Physiology)
- 1990 . . . . . Jerome Friedman, Henry Kendall, and Richard Taylor for deep inelastic scattering of electrons on proton and bound neutrons and for their discovery of the quark (Physics)
- 1992 . . . . . Georges Charpak for wire chamber (“multiwire proportional chamber”) particle detector invented, making possible study of very rare nuclear reactions (Physics)
- 1995 . . . . . (shared) Frederick Reines for the detection of the neutrino (Physics)
- 2002 . . . . . (shared) Raymond Davis and Masatoshi Koshiba for the detection of cosmic neutrinos (Physics)
- 2003 . . . . . Paul C. Lauterbur and Peter Mansfield for MRI as a diagnostic tool (Physiology or Medicine)

# BIBLIOGRAPHY

*The following is a list of the best overall books to read, after which the alphabetized bibliography begins:*

Mackintosh, Ray, Jim Al-Khalili, Bjorn Jonson, and Teresa Pena. *Nucleus: A Trip into the Heart of Matter*. 2<sup>nd</sup> ed. Baltimore, MD: The Johns Hopkins University Press, 2011. A well-written, nonmathematical, brief overview of nuclear physics. Lots of pictures and no equations. A good first book to read.

Lilley, John. *Nuclear Physics: Principles and Applications*. Chichester, England: John Wiley and Sons, 2001. A well-written, comprehensive textbook with some emphasis on applications aimed at undergraduate physics majors. Much more comprehensive, in depth, and mathematically sophisticated than Mackintosh's *Nucleus*.

National Research Council. *Nuclear Physics: Exploring the Heart of Matter*. Washington, DC: The National Academies Press, 2013. Available at <https://www.nap.edu/catalog/13438/nuclear-physics-exploring-the-heart-of-matter>. An up-to-date view of the scientific rationale and objectives of nuclear physics, with an emphasis on current research and future directions. Written for policy makers and other nonscientists. Nonmathematical. Complements the textbooks.

Rhodes, Richard. *The Making of the Atomic Bomb*. New York: Simon and Schuster, 1986. Superbly readable account of the Manhattan Project and the nuclear physics leading up to it. Complements the textbooks.

Jorgenson, Timothy J. *Strange Glow: The Story of Radiation*. Princeton, NJ: Princeton University Press, 2016. Superbly readable account telling the history of our knowledge of radiation with delightful stories and anecdotes about the scientists who made the discoveries. Complements the textbooks.

Mahaffey, James. *Atomic Awakening*. New York: Pegasus Books, 2009. Up-to-date and thorough discussion of the history and future of nuclear power. Well written and sprinkled with humor (only partially macabre). Excellent inside look at what really happened by a nuclear engineer. Excellent companion to lectures 15–20.

---

Agency for Toxic Substances and Disease Registry. “Radon Toxicity.” <https://www.atsdr.cdc.gov/csem/csem.asp?csem=8&po=0>. Continuing Medical Education module on the sources and dangers of radon.

Akpan, Nsikan. “This Supernova Blast Was So Close, It Littered the Ocean Floor with Radioactive Dust.” PBS NewsHour, Science Wednesday, April 6, 2016. <http://www.pbs.org/newshour/updates/supernova-radioactive-blast-litter-ocean-dust/>. Discusses finding radioactive Iron-60 in ocean cores and what it means about the history of nearby supernovas about 13 million years ago.

American Association of Variable Star Observers. “Supernova 1987A.” [https://www.aavso.org/vsots\\_sn1987a](https://www.aavso.org/vsots_sn1987a). Good description of the discovery and subsequent behavior of supernova 1987A and supernovas in general. Not much detail on the neutrino detection.

Arnold, Carrie. “Cold War Bomb Testing Is Solving Biology’s Biggest Mysteries.” *NOVA Next*, December 11, 2013. <http://www.pbs.org/wgbh/nova/next/body/bomb-pulse/>. Discussion of the uses of bomb-pulse carbon dating for brain research, forensic analysis of deaths, etc.

“Asgard’s Fire.” *The Economist*, April 12, 2014. <https://www.economist.com/news/science-and-technology/21600656-thorium-element-named-after-norse-god-thunder-may-soon-contribute>. Discussion of the prospects for thorium reactors.

Bahcall, John N., and Raymond David Jr. "Solar Neutrinos: A Scientific Puzzle." *Science* 191 (1976): 264–267. Good description of the solar neutrino problem as of 1976.

Baras, Colin. "Exploding Stars Could Have Kick-Started Our Ancestor's Evolution." *New Scientist*, October 9, 2017. [https://www.newscientist.com/article/2149763-exploding-stars-could-have-kick-started-our-ancestors-evolution/?cmpid=NLC|NSNS|2017-1210-GLOBAL&utm\\_medium=NLC&utm\\_source=NSNS](https://www.newscientist.com/article/2149763-exploding-stars-could-have-kick-started-our-ancestors-evolution/?cmpid=NLC|NSNS|2017-1210-GLOBAL&utm_medium=NLC&utm_source=NSNS). Describes the hypothesis that cosmic rays from a "nearby" star could have caused lightning that sparked forest fires that transformed east African forest to savannah.

Blitz, Matt. "When Kodak Accidentally Discovered A-Bomb Testing." *Popular Mechanics*, June 20, 2016. <http://www.popularmechanics.com/science/energy/a21382/how-kodak-accidentally-discovered-radioactive-fallout/>. The first (inadvertent) remote monitoring of a nuclear test.

Bodansky, David. *Nuclear Energy: Principles, Practices, and Prospects*. 2<sup>nd</sup> ed. New York: Springer and AIP Press, 2004. Superb coverage of radiation, nuclear reactions, and nuclear energy. Some equations, most can be glossed over.

Bolus, Norman. "NCRP Report 160 and What It Means for Medical Imaging and Nuclear Medicine." *Journal of Nuclear Medicine Technology* 41, no. 4 (2013): 255–261. A more accessible summary of NCRP Report 160.

Borel, Brooke. "Making New Elements." *Popular Science*, May 2013. <https://www.popsci.com/science/article/2013-04/making-new-elements>. Readable description of how new elements are made.

Bushberg, Jerrold T. "Radiation Exposure and Contamination." Merck Manual Professional Version. <http://www.merckmanuals.com/professional/injuries-poisoning/radiation-exposure-and-contamination/radiation-exposure-and-contamination>. Thorough discussion of the sources and effects of radiation contamination. The authoritative medical source.

Capellaro, Paola. “Course 22.02: Introduction to Applied Nuclear Physics.” MIT Open Course Ware course notes. <https://ocw.mit.edu/courses/nuclear-engineering/22-02-introduction-to-applied-nuclear-physics-spring-2012/>. Aimed at MIT undergraduates, so somewhat more advanced than this course. Very clear notes. Excellent figures. The first chapter is very accessible.

Christian, Paul, and Kristen Waterstram-Rich, eds. *Nuclear Medicine and PET/CT*. Maryland Heights, MO: Mosby Elsevier, 2007. One of the standard textbooks for nuclear medicine technicians. More detail than you probably want. Excellent pictures.

Clery, Daniel. “Fusion’s Restless Pioneers.” *Science* 345 (July 25, 2014): 370–375. Overview of the privately funded fusion efforts.

Collins, John. “Parton Distribution Functions.” *Scholarpedia* 7, no. 7 (2012): 10851. [http://www.scholarpedia.org/article/Parton\\_distribution\\_functions\\_%28definition%29](http://www.scholarpedia.org/article/Parton_distribution_functions_%28definition%29). Describes the mathematical formalism behind the parton (quark and gluon) distribution functions. Intended for scientists, but available to everyone.

Collon, Phillippe. “Using Nuclear Techniques to Analyze Art.” Presentation at the Linda Hall Library. <https://vimeo.com/66107935>. An excellent 1-hour lecture on using selected nuclear physics techniques to help attribute art works, determine their composition, and even detect forgeries.

Cowan, George A. “A Natural Fission Reactor.” *Scientific American* 235, no. 1 (July 1976): 36–47. Best-known article about the Oklo natural fission reactor.

Cullings, Harry M. “Impact on the Japanese Atomic Bomb Survivors of Radiation Received from the Bombs.” *Health Physics* 106 (2014): 281–293. Summarizes the final results of the Life Span Study. Authoritative.

Deutch, John, et al. *The Future of Nuclear Power*. Cambridge: Massachusetts Institute of Technology, 2003. Available at <http://web.mit.edu/nuclearpower/>. Addresses the interrelated set of technical, economic, environmental, and political issues related to deploying new nuclear facilities.

Deutch, John, et al. *Update of the MIT 2003 Future of Nuclear Power*. Cambridge: Massachusetts Institute of Technology, 2009. Available at <http://web.mit.edu/nuclearpower/pdf/nuclearpower-update2009.pdf>. An MIT study on the future of nuclear power.

Drake, Nadia. “In a First, Gravitational Waves Linked to Neutron Star Crash.” *National Geographic*, October 16, 2017. <https://news.nationalgeographic.com/2017/10/gravitational-waves-discovered-neutron-stars-pictures-science/?no-cache>. Description of the first detected neutron-star collision and of the evidence for the copious production of gold and other heavy elements in the collision.

Dworschak, Manfred. “Is Radiation as Bad as We Thought?” *Spiegel Online*, April 26, 2016. <http://www.spiegel.de/international/world/chernobyl-hints-radiation-may-be-less-dangerous-than-thought-a-1088744.html>. Newspaper discussion of the dangers of radiation on the 30<sup>th</sup> anniversary of Chernobyl.

Dyson, George. *Project Orion: The True Story of the Atomic Spaceship*. New York: Henry Holt and Company, 2002. A detailed description of US efforts to use nuclear bombs to propel a spaceship.

Ellis, John, and David Schram. “Could a Nearby Supernova Explosion Have Caused a Mass Extinction?” CERN-TH.6805/93, 1993. <https://arxiv.org/abs/hep-ph/9303206>. Examines the probability of nearby supernovas and their effect on life on Earth, typically through destruction of the ozone layer and the resulting excess of ultraviolet radiation reaching the surface of the Earth.

Engelmann, W. “Radium Emanation Therapy.” *Lancet* 1 (May 3, 1913): 1225–1258. The first paper describing radiation therapy.

Feltese, Joel. "Introduction to Parton Distribution Functions." Scholarpedia 5, no. 11 (2012): 10160. [http://www.scholarpedia.org/article/Introduction\\_to\\_Parton\\_Distribution\\_Functions](http://www.scholarpedia.org/article/Introduction_to_Parton_Distribution_Functions). Accessible description of parton distribution functions and how they are measured. Intended for scientists, but available to everyone.

Fields, Brian. "When Stars Attack! In Search of Killer Supernova Explosions." Public lecture presented at University of Kansas, April 18, 2016. <https://www.youtube.com/watch?v=ND6u4Rnq0g0>. An entertaining lecture by a top scientist.

Fountain, Henry. "On Nuclear Waste, Finland Shows U.S. How It Can Be Done." *New York Times*, June 9, 2017. <https://www.nytimes.com/2017/06/09/science/nuclear-reactor-waste-finland.html?mcubz=1>. A news report on the progress of the Finnish waste repository.

FRIB Users Organization. *FRIB: Opening New Frontiers in Nuclear Science*. August 2012. [https://www.frib.msu.edu/\\_files/pdfs/frib\\_opening\\_new\\_frontiers\\_in\\_nuclear\\_science.pdf](https://www.frib.msu.edu/_files/pdfs/frib_opening_new_frontiers_in_nuclear_science.pdf). Describes the physics motivation for building the Facility for Rare Isotope Beams (FRIB). Very accessible. Aimed at readers in the US Department of Energy and the US Congress.

Friedman, Jerome. "Deep Inelastic Scattering: Comparisons with the Quark Model." 1990 Nobel Prize Lecture. *Reviews of Modern Physics* 63 (1991): 615. [https://www.nobelprize.org/nobel\\_prizes/physics/laureates/1990/friedman-lecture.html](https://www.nobelprize.org/nobel_prizes/physics/laureates/1990/friedman-lecture.html). Describes the experiments performed to receive the Nobel Prize. Provides fascinating historical and technical detail.

"Fusion." [Nobelprize.org](http://www.nobelprize.org/nobel_prizes/themes/physics/fusion/sun_1.html). Nobel Media AB 2014. [http://www.nobelprize.org/nobel\\_prizes/themes/physics/fusion/sun\\_1.html](http://www.nobelprize.org/nobel_prizes/themes/physics/fusion/sun_1.html). Nontechnical discussion of the age of the Sun.

Geiger, Hans, and Ernest Marsden. "On a Diffuse Reflection of the  $\alpha$ -Particles." *Proceedings of the Royal Society* 82 (A): 495–500. Archived at <https://web.archive.org/web/20080102232956/http://dbhs.wvusd.k12.ca.us/webdocs/Chem-History/GM-1909.html>. The classic paper describing the Rutherford scattering experiment. Written clearly.

Glascock, Michael. "Overview of Neutron Activation Analysis." Archaeometry Laboratory, University of Missouri Research Reactor. [http://archaeometry.missouri.edu/naa\\_overview.html](http://archaeometry.missouri.edu/naa_overview.html). Excellent detailed description of neutron activation analysis.

GlobalSecurity.org. "Uranium Enrichment Techniques." <http://www.globalsecurity.org/wmd/intro/u-enrichment.htm>. A thorough description of all the different uranium enrichment techniques. Five pages per month are free.

Gould, Todd A., and Molly Edmonds. "How MRI Works." <http://science.howstuffworks.com/mri.htm>. Excellent article on how MRI works.

Gruppen, Claus. *Particle Detectors*. Cambridge: Cambridge University Press, 2008. A description of modern particle detectors and spectrometers, aimed at working scientists.

Hamilton, Tyler. "A New Approach to Fusion." *Technology Review*, July 31, 2009. <https://www.technologyreview.com/s/414559/a-new-approach-to-fusion/>. Describes the magnetized target fusion research of General Fusion.

Health Physics Society. "Radiation Exposure during Commercial Airline Flights." <http://hps.org/publicinformation/ate/faqs/commercialflights.html>. Summarizes the published research on radiation doses received by people who fly, including passengers and crew.

Henley, Ernest, and Alejandro Garcia. *Subatomic Physics*. 3<sup>rd</sup> ed. Singapore: World Scientific, 2007. An advanced undergraduate textbook with excellent descriptions of many phenomena. One of the standard texts. Very accessible in places, even for the nonmathematical reader.

Hewitt, Paul. *Conceptual Physics*. 12<sup>th</sup> ed. New York: Pearson Press, 2014. An excellent conceptual-level discussion of radiation, radioactivity, health effects, fission, and fusion (chapters 33 and 34). Older editions are equally good and much less expensive.

International Nuclear Safety Advisory Group. *INSAG-7—The Chernobyl Accident: Updating of INSAG-1*. Vienna: International Atomic Energy Agency, 1992. [http://www-pub.iaea.org/MTCD/publications/PDF/Pub913e\\_web.pdf](http://www-pub.iaea.org/MTCD/publications/PDF/Pub913e_web.pdf). The official international investigation report of the Chernobyl disaster.

Jefferson Lab. “Jefferson Lab Virtual Tour.” <https://www.jlab.org/virtual-tour>.

Kendal, Henry. “Deep Inelastic Scattering: Experiments on the Proton and the Observation of Scaling.” 1990 Nobel Prize Lecture. *Reviews of Modern Physics* 63 (1991): 597. [https://www.nobelprize.org/nobel\\_prizes/physics/laureates/1990/kendall-lecture.html](https://www.nobelprize.org/nobel_prizes/physics/laureates/1990/kendall-lecture.html). Describes the experiments performed to receive the Nobel Prize. Provides fascinating historical and technical detail.

Krane, Kenneth. *Introductory Nuclear Physics*. 3<sup>rd</sup> ed. New York: John Wiley and Sons, 1987. One of the standard nuclear physics textbooks used in undergraduate courses for physics majors. Comprehensive, but beginning to be dated. Assumes a working knowledge of calculus.

LeBlanc, Francis. *An Introduction to Stellar Astrophysics*. Chichester, England: John Wiley & Sons, 2010. Excellent description of stellar astrophysics at the sophomore/junior level. The chapter on nucleosynthesis and stellar evolution is very accessible and thorough.

Leo, W. R. *Techniques for Nuclear and Particle Physics Experiments*. Berlin: Springer-Verlag, 1994. Thorough introduction to all the different kinds of particle detectors and how they work. Intended for people who will use the detectors.

Mackova, Anna, et al., eds. *Nuclear Physics for Cultural Heritage*. Nuclear Physics Division of the European Physical Society. <http://www.edp-open.org/images/stories/books/fulldl/Nuclear-physics-for-cultural-heritage.pdf>. A thorough overview of the different nuclear physics techniques used to characterize objects in the fields of history, art history, and archaeology. Also includes many examples.

Mahaffey, James. *Atomic Accidents*. New York: Pegasus Books, 2014. Up-to-date and thorough discussion of the causes and results of nuclear meltdowns and disasters, from the first misadventures with radiation to Fukushima. Well written and sprinkled with humor (only partially macabre). Excellent inside look at what really happened by a nuclear engineer.

Markandya, A., and P. Wilkinson. "Electricity Generation and Health." *The Lancet* 370 (2007): 979–990. [doi.org/10.1016/S0140-6736\(07\)61253-7](https://doi.org/10.1016/S0140-6736(07)61253-7). An evaluation of the health risks of different energy-generation technologies. (Caveat: Estimating the number of deaths from small doses spread over large populations is always extremely uncertain.)

MIT Center for Advanced Nuclear Energy Systems Symposium. *Nuclear beyond LWRs: A Celebration of Neil Todreas' Career and Passion for Advanced Reactors*. Cambridge, MA, November 1–2, 2016. <https://energy.mit.edu/wp-content/uploads/2016/11/CANES-Nuclear-Beyond-LWRs-2016.pdf>. A collection of talks on different advanced nuclear energy topics. Represents the state of the art as of late 2016.

Morrison, Phillip. "Where Fiction Became Ancient Fact." *Scientific American* 278, no. 6 (June 1, 1998): 99–101. Good description of the Oklo natural fission reactor.

Moskowitz, Clara. "Ancient Roman Metal Used for Physics Experiments Ignites Scientific Feud." *Scientific American* 18 (December 2013). <https://www.scientificamerican.com/article/ancient-roman-lead-physics-archaeology-controversy/>. Description of why physicists prefer Roman-era lead to today's lead.

National Council on Radiation Protection and Measurements. *Report No. 160: Ionizing Radiation Exposure of the Population of the United States*. 2009. Detailed information on the radiation exposure of the US population.

National Research Council. *Health Risks from Exposure to Low Levels of Ionizing Radiation: BEIR VII Phase 2*. Washington, DC: The National Academies Press, 2006. Available at <https://doi.org/10.17226/11340>. The definitive National Academy of Sciences study of the effects of low levels of ionizing radiation.

Nutall, W. J. “Fusion as an Energy Source: Challenges and Opportunities.” Institute of Physics Report, September 2008. [http://iop.org/publications/iop/2008/file\\_38224.pdf](http://iop.org/publications/iop/2008/file_38224.pdf). Very accessible, thorough discussion of the prospects for fusion power.

———. *Nuclear Renaissance: Technologies and Policies for the Future of Nuclear Power*. Bristol, UK: Institute of Physics Publishing, 2005. Good description of modern nuclear technologies, along with practical and regulatory concerns.

Oak Ridge Associated Universities. “Shoe-Fitting Fluoroscope.” <http://www.ornl.gov/PTP/collection/shoefittingfluor/shoe.htm>. Description of the nature and history of shoe fluoroscopy, including many pictures of fluoroscopes and related items.

Park, Robert. *Voodoo Science: The Road from Foolishness to Fraud*. Oxford: Oxford University Press, 2000. An entertaining and well-researched exploration of scientific error, bad science, and pseudoscience, focusing on cold fusion.

PhET Interactive Simulations. “Nuclear Fission.” University of Colorado Boulder. <https://phet.colorado.edu/en/simulation/nuclear-fission>. Great simulation of how one uranium-235 nucleus fissions, how a chain reaction develops among many uranium-235 and uranium-238 nuclei, and how a chain reaction proceeds in a reactor. This was developed by one of the top physics education research groups in the country, founded by Nobel Laureate Carl Weiman.

Ritchie, Hannah. “It Goes Completely against What Most Believe, But out of All Major Energy Sources, Nuclear Is the Safest.” *Our World in Data* (blog). July 24, 2017. <https://ourworldindata.org/what-is-the-safest-form-of-energy/>. A nontechnical description of electricity generation and health using data from Markandya and Wilkinson’s *Lancet* article.

Rosen, S. Peter. “Ray Davis: Indefatigable Neutrino Pioneer.” *CERN Courier*, September 7, 2006. <http://cerncourier.com/cws/article/cern/29699>. Obituary of Ray Davis, the founder of neutrino astrophysics and the first person to measure neutrinos from the Sun.

Rutherford, Ernest. “The Scattering of  $\alpha$  and  $\beta$  Particles by Matter and the Structure of the Atom.” *Philosophical Magazine* 6, vol. 21 (May 1911). Archived at <http://www.lawebdefisica.com/arts/structureatom.pdf>. The classic paper interpreting the results of Geiger and Marsden’s measurements in terms of the nuclear model.

Taylor, Richard E. “Deep Inelastic Scattering: The Early Years.” 1990 Nobel Prize Lecture. *Reviews of Modern Physics* 63 (1991): 573. [https://www.nobelprize.org/nobel\\_prizes/physics/laureates/1990/taylor-lecture.html](https://www.nobelprize.org/nobel_prizes/physics/laureates/1990/taylor-lecture.html). Describes the experiments performed to receive the Nobel Prize. Provides fascinating historical and technical detail.

Temple, James. “Small Reactors Could Kick-Start the Stalled Nuclear Sector.” *Technology Review*, July 17, 2017. <https://www.technologyreview.com/s/608271/small-reactors-could-kick-start-the-stalled-nuclear-sector/>. Discussion of the prospects for small modular fission reactors.

The KamLAND Collaboration. “Partial Radiogenic Heat Model for Earth Revealed by Geoneutrino Measurements.” *Nature Geoscience* 4 (2011): 647–651. Technical article describing the measurement of geoneutrinos and its relation to the energy released in the Earth by radioactive decay of uranium-238 and thorium-232.

“The Oklo Reactor: A Nuclear Detective Story.” *re-actions* 9, September 1993. <http://www.ans.org/pi/np/oklo/docs/reactions.pdf>. Description of how scientists figured out what happened at the Oklo reactor.

Thomson, Sir William (Lord Kelvin). “On the Age of the Sun’s Heat.” *Macmillan’s Magazine* 5 (March 5, 1862): 388–393. From reprint in *Popular Lectures and Addresses*, 2<sup>nd</sup> ed., 1: 356–376. Available at [http://zapatopi.net/kelvin/papers/on\\_the\\_age\\_of\\_the\\_suns\\_heat.html](http://zapatopi.net/kelvin/papers/on_the_age_of_the_suns_heat.html). Kelvin’s original article on the age of the Sun. A fascinating look into the thought processes of one of the 19<sup>th</sup> century’s greatest scientists. Somewhat archaic language and terminology.

Tilakaratra, Prasanna. “How Magnetic Resonance Imaging Works, Explained Simply.” [https://www.howequipmentworks.com/mri\\_basics/](https://www.howequipmentworks.com/mri_basics/). Good step-by-step description of MRI, with lots of images.

United Nations Scientific Committee on the Effects of Atomic Radiation. *Sources and Effects of Ionizing Radiation*. Volume I: Sources and Volume II: Effects. Vienna: United Nations, 2011. Available at [http://www.unscear.org/docs/reports/2008/11-80076\\_Report\\_2008\\_Annex\\_D.pdf](http://www.unscear.org/docs/reports/2008/11-80076_Report_2008_Annex_D.pdf). Summarized in *The Chernobyl Accident: UNSCEAR’s Assessments of the Radiation Effects*, <http://www.unscear.org/unscear/en/chernobyl.html>. Full description of the health effects of the Chernobyl accident. The brief, readable summary gives a clear description of the health effects.

US Department of Health and Human Services. “REMM Radiation Emergency Medical Management.” <https://www.remm.nlm.gov/index.html>. Useful information from the US government.

US Nuclear Regulatory Commission. “Radiation Protection.” <https://www.nrc.gov/about-nrc/radiation.html>. Brief but thorough description on the sources and effects of radiation from the official US government website. It includes a link to the Personal Annual Radiation Dose Calculator.

———. “Uranium Enrichment.” <https://www.nrc.gov/materials/fuel-cycle-fac/ur-enrichment.html>. A good description of the main enrichment techniques.

White, Martin. “Big Bang Nucleosynthesis.” <http://w.astro.berkeley.edu/~mwhite/darkmatter/bbn.html>. Good description of big bang nucleosynthesis from an expert in the field.

———. “Origin of the Light Elements.” <http://w.astro.berkeley.edu/~mwhite/darkmatter/bbndetails.html>. Good description of big bang nucleosynthesis from an expert in the field.

Wilczek, Frank. “The Origin of Mass.” *MIT Physics Annual 2003*. 24–35. Available at [http://frankwilczek.com/Wilczek\\_Easy\\_Pieces/342\\_Origin\\_of\\_Mass.pdf](http://frankwilczek.com/Wilczek_Easy_Pieces/342_Origin_of_Mass.pdf). Good description of quantum chromodynamics, confinement, asymptotic freedom, and the origin of mass.

Wilson, Mark. “Electron-Scattering Experiments Resolve Short-Range Correlations among Nucleons.” *Physics Today*, July 2008. <http://physicstoday.scitation.org/doi/full/10.1063/1.2962997>. Description of the latest research on nucleon behavior in nuclei.

Wiringa, R. B., and Steven C. Pieper. “Evolution of Nuclear Spectra with Nuclear Forces.” *Physical Review Letters* 89, no. 18 (2002): 182501-1–4. State-of-the-art calculation of light nuclei using different nucleon-nucleon interactions to investigate exactly why there are no stable mass 5 or 8 nuclei. Very technical article.

Wong, Samuel S. M. *Introductory Nuclear Physics*. Englewood Cliffs, NJ: Prentice Hall, 1990. A good advanced-undergraduate level nuclear physics textbook.

World Nuclear Association. “Advanced Nuclear Power Reactors.” <http://www.world-nuclear.org/information-library/nuclear-fuel-cycle/nuclear-power-reactors/advanced-nuclear-power-reactors.aspx>. A review of Generation III nuclear power plants that covers their general properties as well as the specific designs.

———. “Nuclear Power in the World Today.” <http://world-nuclear.org/information-library/current-and-future-generation/nuclear-power-in-the-world-today.aspx>. Survey of the current status of nuclear power generation. Updated periodically. Pronuclear. One of many informative articles on the World Nuclear Association’s website.

———. “Storage and Disposal of Nuclear Waste.” <http://www.world-nuclear.org/information-library/nuclear-fuel-cycle/nuclear-wastes/storage-and-disposal-of-radioactive-wastes.aspx>. A review of radioactive waste storage options. Pronuclear. One of many informative articles on the World Nuclear Association website.

# IMAGE CREDITS

6	Library of Congress, Prints and Photographs Division, LC-DIG-ggbain-03392.
7	Library of Congress, Prints and Photographs Division, LC-DIG-ggbain-07682.
20	The Teaching Company Collection.
21	© abadonian/iStock/Thinkstock.
25	© webarama/iStock/Thinkstock.
27	© chengyuzheng/iStock/Thinkstock.
36	© Photoman195/iStock/Thinkstock.
39	© monkeybusinessimages/iStock/Thinkstock.
51	© diego_cervo/iStock/Thinkstock.
52	© Rawpixel/iStock/Thinkstock.
62	NARA.
70, 78, 80	The Teaching Company Collection.
81	Boston Museum of Science/Wikimedia Commons/CC BY-SA 3.0.
83	The Teaching Company Collection.
84	© 2014–2017 CERN.
90–93	The Teaching Company Collection.
96	Argonne National Laboratory.
99	The Teaching Company Collection.
102	Jlab.
110, 114	The Teaching Company Collection.
116	Thomas Jefferson National Accelerator Facility.
122–125, 127	The Teaching Company Collection.
133	Library of Congress, Prints and Photographs Division, LC-B2-6358-11.
143	The Teaching Company Collection.
161	Fastfission/Wikimedia Commons/Public Domain.
167	NARA.
168	Fastfission/Wikimedia Commons/Public Domain.
169	Ausis/Wikimedia Commons/CC BY-SA 2.5.
170	NARA.
176	The Teaching Company Collection.
179	© DanielPrudek/iStock/Thinkstock.
186	© Dobresum/iStock/Thinkstock.
190	The Teaching Company Collection.
193	Tokyo Electric Power Co., TEPCO/flickr/CC by 2.0.
205	Picoterawatt/Wikimedia Commons/Public Domain.

214, 215, 217	The Teaching Company Collection.
225	National Library of Medicine.
228	National Cancer Institute/General Motors Cancer Research Foundation.
236	© urfinguss/iStock/Thinkstock.
239, 249	The Teaching Company Collection.
250	Hokanomono/Wikimedia Commons/Public Domain.
251	© karandaev/iStock/Thinkstock.
252	© kolesnikovserg/iStock/Thinkstock.
260, 262, 265	The Teaching Company Collection.
267	Jlab.